

TECHNICAL DATA



For assembling, use and maintenance
of the combined hot water heater



Centrometal d.o.o. Glavna 12, 40306 Macinec, Croatia
sales department tel: +385 40 372 640
central tel: +385 40 372 600, fax: +385 40 372 611
technical office tel: +385 40 372 620, fax: +385 40 372 621

www.centrometal.hr
e-mail: tehnicki.ured@centrometal.hr

Type		LKB Digi 100	LKB Digi 120
Capacity	lit.	100	120
Water heater diameter A	mm	475	475
Height of the water heater B	mm	950	1090
Tube heat exchanger	m ²	0,42	0,42
	R"	3/4	3/4
Cold water inlet connection	R"	1/2	1/2
Cold water outlet connection	R"	1/2	1/2
Circulation	R"	1/2	1/2
Voltage	V~	230	230
Frequency	Hz	50	50
Type of electric current		~	~
Electric heater	W	2000	2000
Max. additional power	W	200	200
Max. total power	W	2000	2000
Water heater mass	kg	35,5	40
Max. operating pressure	bar / MPa	6 / 0,6	6 / 0,6
Ip protection		IP 24	IP 24

Image 1. - Essential parts of combined water heater LKB-Digi

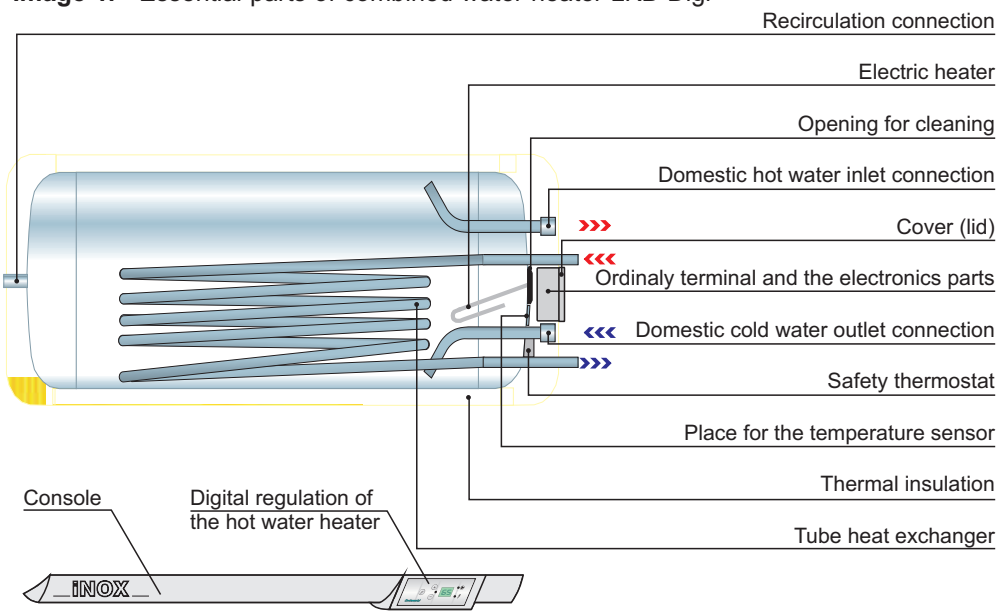

8.0. Maintenance of the combined hot water heater

8.1. Cleaning of the combined hot water heater

At least once in two years it is necessary to check and clean it from the scale and sediment. Before the cleaning it is obligatory to disconnect the combined hot water heater from the power supply and discharge it (through the cock for drainage on the cold water installation). Then take off the safety lid of the ordinary terminal and the opening for cleaning which is located on the lateral side of the combined hot water heater (the lid is attached with one screw), take off the electrical supply from the electric heater, then take off the regulation (first take off the plate which is placed over the regulation, and then take off the box with the regulation). Then unscrew the nut on the flange and take off the flange, seal and opposite flange with electric heater. After the cleaning of the boiler it is necessary to attach the electric heater with the flanges and seal back to position, connect the power on the electric heater and placed the safety lid back to its position.

8.2. Electric heater replacement

Before the replacement of the electric heater it is necessary to disconnect the combined hot water heater from the power supply and discharge it (through the drainage cock on the cold water installation). Then removed the safety lid of the ordinary terminal and the opening for cleaning which is located on the lateral side of the combined hot water heater (the lid is attached with one screw), removed the electrical supply from the electric heater, then take off the regulation (first take off the plate which is placed over the regulation, and then take off the box with the regulation). Then unscrew the nut on the flange and removed the flange, seal and opposite flange with electric heater. After this replace the electric heater with the flange, seal and opposite flange, attach it back to its place into the combined hot water heater, connect and put back the safety lid.

- Choosing the heating type of the combined hot water heater (pump or electric heater):

If You simultaneously push the button P and button \ominus , the GREEN LED which represent the type how the combined hot water heater is currently heated (circulation pump or electric heater) will start to blink. By pushing the button \oplus or \ominus You change the type of operating which is marked with the blinking of the GREEN LED diode below the certain symbol. On the display is print out value of the propound temperature. After the choosing the type of heating, after 5 second value on the display go back to the value of instantaneous temperature in the combined hot water heater, and the new set type of heating is recorded in the regulation memory.

- Option against freezing:

If the combined hot water heater is heating through the circulation pump it is possible to switch on/off the option against freezing of the combined hot water heater. When temperature in the combined hot water heater fall down below $6\text{ }^{\circ}\text{C}$ and if the option against freezing is switch on the regulation switch on the electric heater. If You simultaneously push the button \ominus and button \oplus ; after 5 second RED LED diode will start to blink and on the display is print out the mark 1 or 0. Mark 1 represent that the option against freezing is switch on, while mark 0 represent that the option against freezing is switch off. By pushing the button \oplus and \ominus You are able to change if this option is switch on or switch off. After the choosing the way of operating, after 5 second value on the display is gone back to the value of the instantaneous temperature in the combined hot water heater and the new set option against the freezing is record in the memory of regulation. REMARK: if You empty the combined hot water heater, option against freezing is obligatory to be switch off.

7.2. Preadjusted regulation parameter

- The propound temperature in the combined hot water heater is set on to: **$55\text{ }^{\circ}\text{C}$** .
- The way of heating the combined hot water heater is set on to: **circulation pump**.
- Option against freezing: **switch off (0)**.

7.3. Indication of the possible errors

If the display shows (Ξ + number) it means that some errors accures during the operation of the regulation. By the mark on the display, the possible errors are:

- (Ξ 0) temperature sensor of the regulation feel the temperature over $90\text{ }^{\circ}\text{C}$.
- (Ξ 1) the temperature sensor is wrongly installed.
- (Ξ 2) inaccurate temperature sensor or the scan value over the measured area.
- (Ξ 3) wrong value in the memory (EPROM).

For the reset of the memory it is necessary to push the button \ominus and after this the error has to be removed. If the errors appear again please contact the qualified person.

At every error both relays output are switched off until the error is removed.

Image 2. - Essential dimensions of combined water heater LKB-Digi (right version)

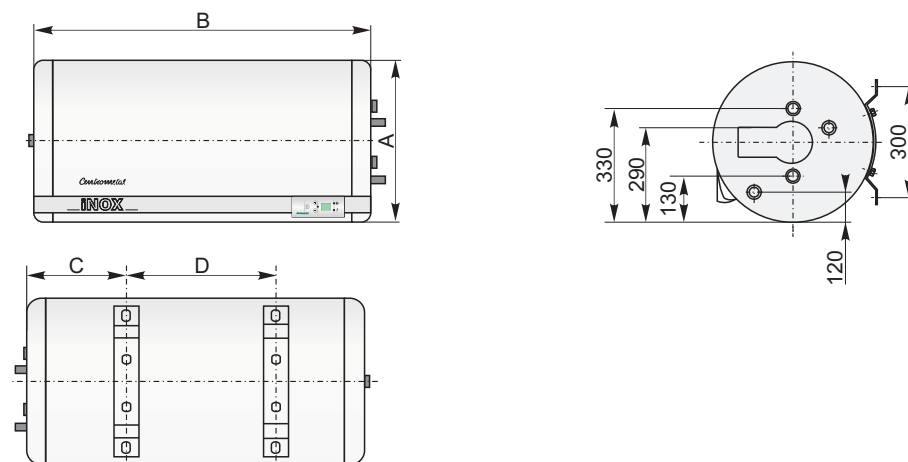

LKB-Digi		100	120
Water heater diameter A	(mm)	475	475
Length of the water heater B	(mm)	950	1090
Heigth C	(mm)	272	272
Heigth D	(mm)	415	553

1.0. Introduction

Combined hot water stainless steel heater LKB-Digi produced by Centrometal d.o.o. is constructed by applying of most modern robots welding technology and is made out of high quality material, which is a guarantee for its high performance and generally high quality of the product.

Combined hot water heater LKB-Digi are manufactured in two type of capacity 100 and 120 liter with the connections on the left or right side (LKB-Digi right version, LKB-Digi left version).

They are made out of high quality stainless steel (INOX) and was water tested with probe pressure of 12 bar, the combined hot water heater has an in built tube heat exchanger, an in built electric heater 2 kW and modern digital regulation which control the operating of the hot water heater. They are delivered together with thermal isolation made by stone wool covered by steel casing.

All instructions have to be carefully studied, to learn about correct assembling, handling, use and maintainance. This is necessary in order to enable your hot water boiler to operate according to its purpose and produce heat for your home for many years.

2.0. Purpose

The LKB-Digi is assigned for sanitary hot water production with the tube heat exchanger or/and electric heater. The tube heat exchanger can be connected with oil, gas, electric power or solid fuel firing or can be alternatively connected to the solar collectors (with additional regulation).

Digital water heater regulation steers the operating of the circulation pump of the boiler circuit or starts, if necessary the electric heater in the water heater in dependence of propound parameters of the hot sanitary water temperature and available heat sources.

3.0. Wall mounting

Combined hot water heaters LKB-Digi is foreseen to be wall hanged in the **horizontal position**. For this reason on the backside of the water heater porter are placed which enables an easy installation (IMAGE 3.).

With the combined hot water heater is also delivered the mounting set which is used for the installation of the hot water heater only on the full concrete wall. In mounting set together with screws, nut and inlays is also placed 2 pieces of hermetto coupling which are foreseen for the connection of the tube heat exchanger on the installation of the central heating. The mounting set is packed in the plastic bag and placed near the combined hot water heater in the cardboard box. We recommend the installation of the combined hot water heater by a qualified person.

Image 3. - Mounting of the combined hot water heater LKB-Digi on the wall

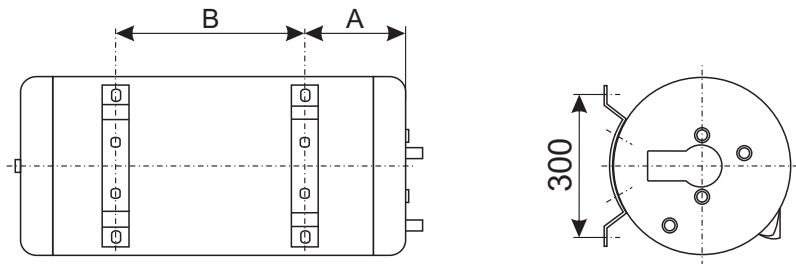

- Nut M8
- Insert plate φ8
- Inlay φ12
- Hanger screw M8x80 mm

TYPE	A	B
LKB-Digi 100	272	415
LKB-Digi 120	272	553

7.0. Temperature regulation in the combined hot water heater

Image 5. - Digital regulation

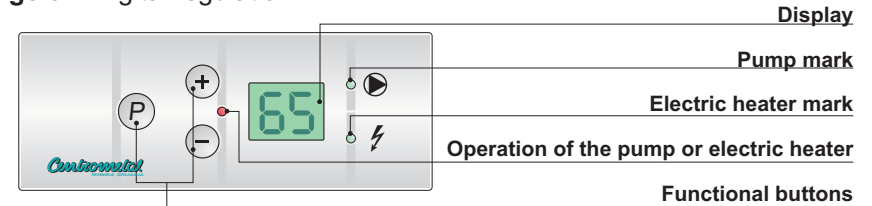

Combined hot water heater LKB-Digi has factory installed digital regulation which lead the heating of the hot water through the boiler with circulation pump (through the tube heat exchanger) or through the electric heater installed in the hot water heater (image 5.). Regulation is operating in that way that it measure instantaneous temperature in the combined hot water heater and compare with the desired (propound) temperature. Regulation has difference set at 2°C, which means if the propound temperature is 55 °C, electric heater or circulation pump will operate as long as the hot water heater achieve propound temperature i.e. at the 55°C the electric heater or circulation pump will shut down. When temperature drop below 53°C in the hot water heater they will switch on again. Display during the operation of the combined hot water heater show the instantaneous temperature in the combined hot water heater. When the switch (P) is pushed on the display is shown the propound (the number has behind them the dots). On the right part of the regulation panel there are two green LED diode which represent the type how the combined hot water heater is heated: UPPER led diode: heating the combined hot water heater with the boiler through the circulation pump; LOWER LED diode: heating the combined hot water heater with the install electric heater. Left the display is placed the RED LED diode which signalize the operation either the electric heater or circulation pump, which can be seen by the symbol below which the green diode light.

7.1. Adjusting of the parameters

- Adjusting the combined hot water heater on the propound temperature:

If You simultaneously push the button (P) and button (+), the RED LED diode will start to blink and with the buttons (+) and (-) You change the value of the propound temperature. When the propound temperature is set, after the 5 second value on the display turns back to the instantaneous temperature in the combined hot water heater, and the new set propound temperature is recorded in the regulation memory.

See the electrical connection on the scheme 4. The power supply of the combined hot water heater is necessary to be done with the connection of the conductor 3x1,5 mm² through the main switch outside the combined hot water heater which switch off both poles (phase and zero) through the introduction line to the ordinary terminal marked with following labels **L** , **N** , \perp .
Preparation for the switching off all poles of the circuit voltage it is obligatory to be install in electrical installation according the public installation legislation.

Image 4. - Inserting the wires into the ordinary terminal of the boiler LKB-Digi

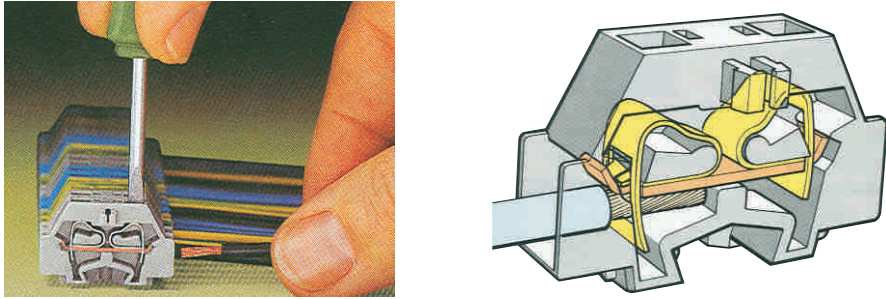

Circulation pump is connected through the introduction line on the ordinary terminal marked with following labels: **L₁** , **N₁** , \perp .
Safety thermostat is placed below the lid of the combined hot water heater behind the box with the print circuit board (Image 1).

Scheme 4. - Connection to the electrical installation

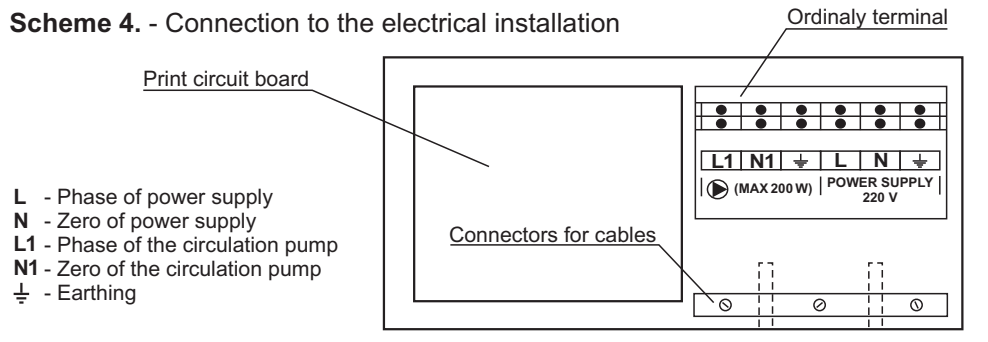

4.0. Connection to the water supply system

The connection of the combined hot water heater to the water supply system must be done with respect to valid technical norms by a qualified person (Scheme 1.). The cold water supply has to be connected with the pipe tube (nipple 1/2") marked with blue sticker, the hot sanitary water drain has to be connected with the pipe tube (nipple 1/2") marked with red sticker. The circulation tube outlet (nipple 1/2"), marked with red sticker, is located on the lateral side of the combined hot water heater.

It is obligatory to install on the cold water supply tube entrance of the hot water heater:

- Safety valve with opening pressure 6 bars.
- Expansion vessel for sanitary water.
- irreversible valve.
- Reducing valve which lowers the pressure of cold water supply pipe on the 4 Bar (if the pressure is higher than this value).
- Water drainage cock (obligatory connect through T-piece).

Drainage with drainage pipe of the safety valve is obligatory to be install in the way that the water can freely leaks from the valve and it is obligatory to install in the area where it never freeze , on the area pressure.

In order to have a long operation life we recommend to install a water softener (Atlas filters), especially in region with city water supply system ("hard" water and water with chlorine) and galvanized water tubes which have harmful effects on stainless steel materials. In order to prolongue the operating life of the electric heater, we recommend on the inlet and outlet and on recirculation of the sanitary water from the combined hot water heater to installation line install minimum 0,5 m plastic tube for sanitary water which endure minimum temperature to 90 °C.

Scheme 1. - Connection of the combined hot water heater LKB-Digi on the water supply system

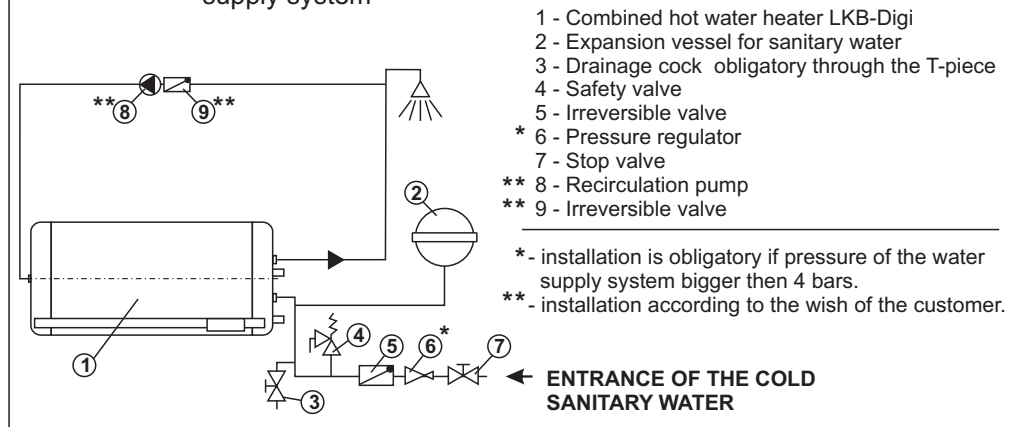

- 1 - Combined hot water heater LKB-Digi
 - 2 - Expansion vessel for sanitary water
 - 3 - Drainage cock obligatory through the T-piece
 - 4 - Safety valve
 - 5 - Irreversible valve
 - * 6 - Pressure regulator
 - 7 - Stop valve
 - ** 8 - Recirculation pump
 - ** 9 - Irreversible valve
- * - installation is obligatory if pressure of the water supply system bigger then 4 bars.
** - installation according to the wish of the customer.

5.0. Connection to the heating system

Scheme 2. show one method how to connect the combined hot water heater to the heating system. In that case the regulation of the heating the sanitary water has a digital regulation which is in built on the hot water heater.

In case there is a boiler regulation of the sanitary water, it is obligatory to in the factory prepared porter on the combined hot water heater insert the sensor of boiler regulation (Scheme 3.).

The hot water boiler (collectors) supply is connected to the tube of heat exchanger marked with red sticker, then the tube of heat exchanger marked with blue sticker served for drainage of cooled boiler water (collectors). The connections of the combined hot water heater and the installation is **obligatory to done by hermetto coupling** (fi 22 mm), and on no account with hard welded joint.

The combined hot water heater is produced in two types, with the connection tube of the heat exchanger on the left or right side which depend of the connection of the installation.

Scheme 2. - Connection of the combined hot water heater LKB-Digi on the heating system

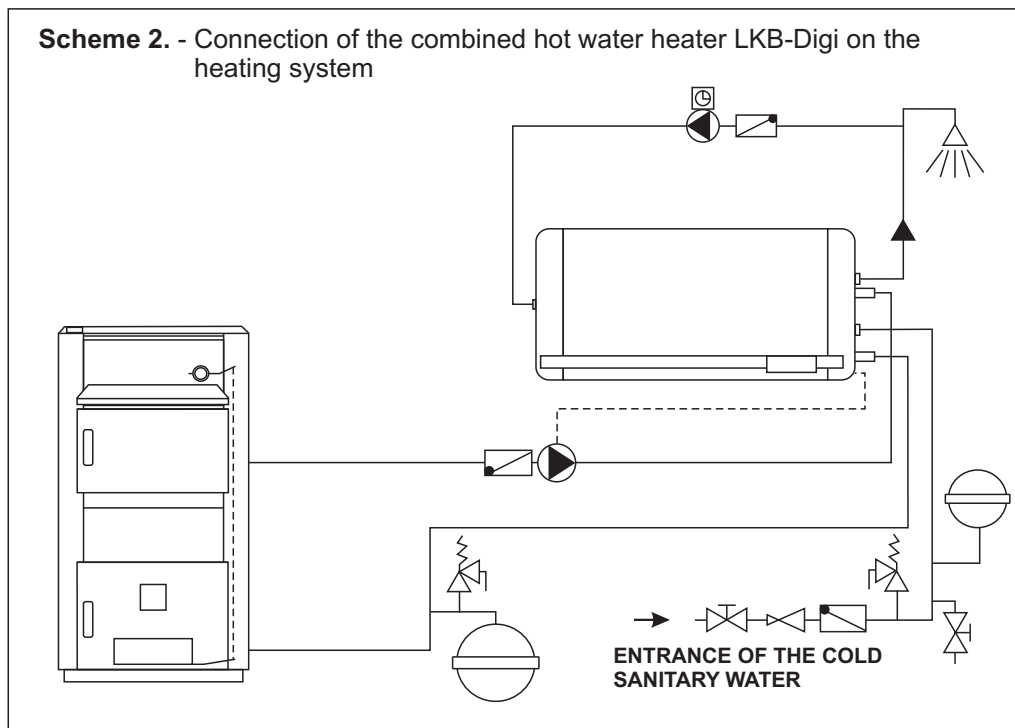

Scheme 3. - Connection of the combined hot water heater LKB-Digi on the heating system

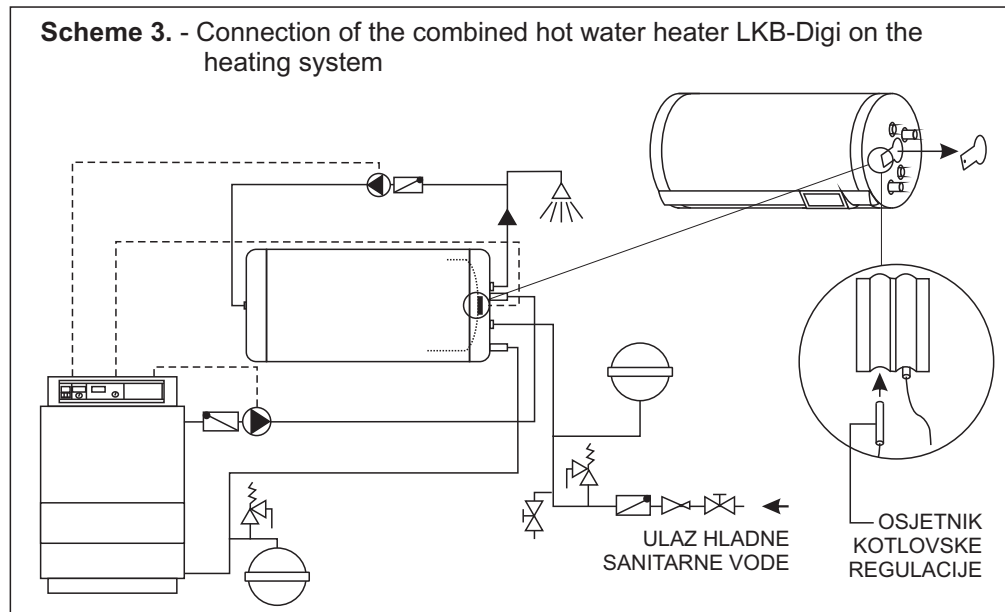

6.0. Electrical connection

All electrical work has to be done under valid technical norms by a qualified person. A complete electrical installation of the combined hot water heater itself was made by the manufacturer. All additional connections (power supply and circulation pump) are made through the ordinal terminal which is placed below the cover on the lateral side of the combined hot water heater. When You take off cover on the lateral side of the combined hot water heater, on the back side through the introduction line it is necessary to insert the wires and bring them to the ordinal terminal. After that take off the cable connectors which are placed on the edge of the PRINT CIRCUIT BOARD, take off the stickers on which says "for the connection see the technical manual" from the ordinal terminals and take off the isolation from the top of the wires. Places the wires in the ordinal terminal one by one (not more then one wires in same time) in the way that you press from upside of the ordinal terminal contact with the screwdriver, then You put in end of the wire with taken off isolation to the limiter in the ordinal terminal, and gently take out screwdriver from the ordinal terminal contact. Before You put the second wire in the ordinal terminal it is obligatory to check if the first wire is correctly attached (check if You can take out the first wire from the ordinal terminal without the help of the screwdriver). It is obligatory to attached the wires to the ordinal terminal like it is shown in image 4. After all the wires are connected on the ordinal terminal it is necessary to fasten it with the cables connectors.