

Air-cleaning for burner CPPL-14/35/50/90

The principle of operation

Air cleaning will be automatically activated after completion of each phase of boiler shutdown. If the work phase of the burner runs continuously, over the factory set for the longest duration of continuous operation, the burner automatically will go into shutdown phase, perform air cleaning and then resumes.

Condition of the equipment ready for operation:

- Equipment is **connected** as shown in Figure 1
- Compressor (1) is **plugged** in 230V
- Compressor power switch is **“turned on”** (2)

Figure 1: Connect the equipment for air-cleaning for burner CPPL-14/35/50/90

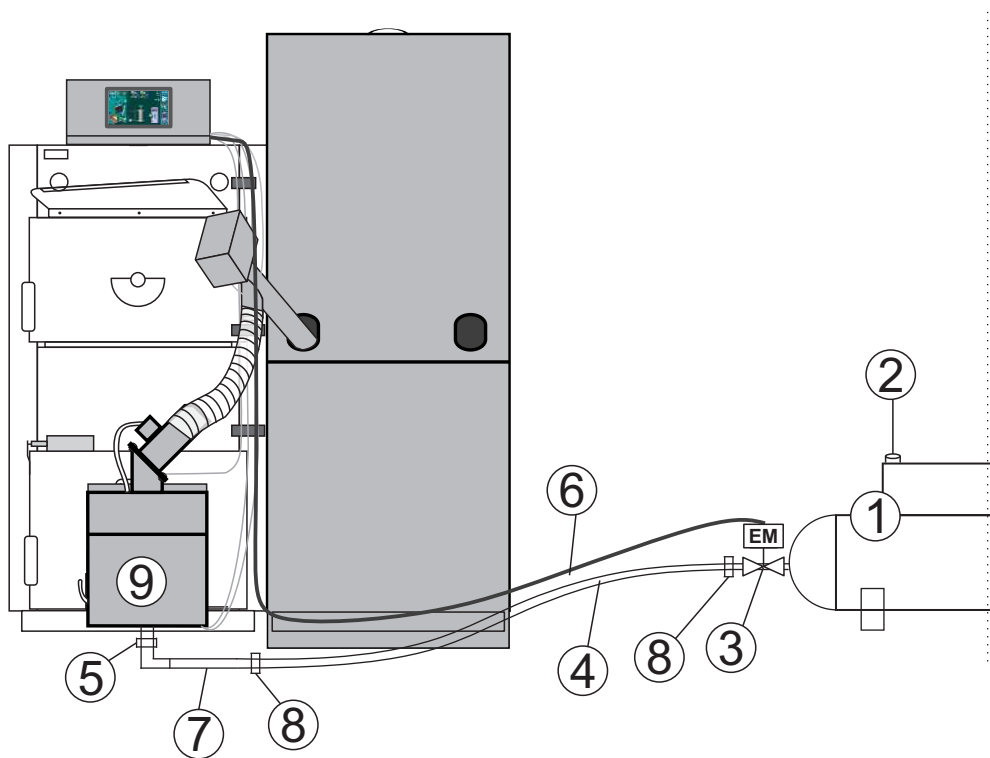

- 1 - Air Compressor
- 2 - Compressor power switch
- 3 - Electromagnetic valve
- 4 - Air hose
- 5 - Holender
- 6 - Electric wire in safety tube
- 7 - Metal connecting tube
- 8 - Quick coupling
- 9 - Burner CPPL-14/35/50/90