

Centrometal

HEATING TECHNIQUE

CENTROMETAL d.o.o. – Glavna 12 – 40306 Macinec – Croatia
tel: +385 40 372 600; fax : +385 40 372 611



TECHNICAL INSTRUCTIONS

USE AND MAINTENANCE

Cm Pelet-set

(40-50 kW)

For boilers:
EKO-CK P 50-60
EKO-CKB P 50



TUPS-4050-K-11-2016-E-N-eng

CONTENTS

1. Introduction.....	3
2. Status of delivery.....	3
3. Component description and technical information.....	4
4. Safety elements.....	5
5. Fuel.....	6
6. Boiler control unit.....	6
6.1. Description of buttons and symbols on the control unit.....	7
6.2. Symbol description.....	7
6.3. Home screen and sanitary water temperature.....	8
6.4. Setting of burner operating parameters.....	8
7. Burner operation.....	12
7.1. Procedure of the first firing.....	12
7.2. Extinction procedure.....	13
8. Control unit operation.....	13
8.1. Firing phase.....	13
8.2. Transition phase.....	13
8.3. Operation phase.....	13
8.4. Extinction phase.....	14
8.5. Operation with timer.....	14
8.6. Anti-frost protection programme.....	15
8.7. Boiler overheating protection.....	15
8.8. Flame goes out during operation.....	15
8.9. Power supply interruption.....	15
8.10. Operation of the regulation in OFF mode / boiler firing with solid fuel.....	15
9. Errors.....	17
9.1. Errors and possible causes.....	18
10. Connectors at control unit.....	19
11. Maintenance of Cm Pelet-set.....	19
12. The possibility of fan lid installing.....	20

1. Introduction

Cm Pelet-set, wood pellet based heating system (nominal burner output **40 to 50 kW**) designed for installation in combined boilers or biomass firing boilers **EKO-CK P** and **EKO-CKB P**, with thermal output from 50 to 60 kW. These technical instructions provide basic product information, its technical characteristics and instructions on use and maintenance of its components. Cm Pelet-set components are of modern design and construction, made of high quality materials having all required certificates. Cm Pelet-set installation and start-up must be carried out by a professional or authorized fitter of manufacturer.

Instructions for fitters/servicemen presenting setting of all parameters of pellet regulation are also supplied with these instructions.

2. Status at delivery

1. Pellet burner CPPL-50
- 2.a.) Set for installation of pellet burner (only new boiler models)
- 2.b) Lower boiler door CPDV (only for models that have special doors for installation of pellet burner)
3. Boiler control unit CPREG
4. Pellet feeder CPPT
5. Pellet tank CPSP

2.1 Pellet burner CPPL

Pellet - burner **CPPL-50** (nominal thermal output 40 to 50 kW, for boilers EKO-CK P 50-60, EKO-CKB P 50) consists of high quality components and made of certified built-in materials. The burner includes high-efficiency fan which, by aid of specially shaped burner grate creates a flame as in standard burners. The burner also includes electrical heater which, via the control unit, automatically ignites pellets when required. A built-in photo-cell serves for flame detection in the burner. Special shape of a combustion chamber enables good mixing of air and fuel which gives high efficiency of combustion. Depending on the operating phase and set output, fan revolution number, i.e. air supply to the chamber is changed. The burner is designed for installation into prepared openings at the lower boiler door CPDV. The burner is factory wired and it has to be connected to the boiler control unit CPREG.

2.2 Lower boiler door - factory mounted onto EKO-CK P boilers

Lower boiler door **CPDV** with an opening adapted for pellet burner is supplied with the pellet burner CPPL (except in case of supply of a boiler with Cm Pelet-set, when the lower boiler door CPDV is pre-installed onto boiler). Standard boiler door has to be dismantled from the boiler instead of which the supplied boiler door CPDV is installed onto which the pellet burner is assembled.

2.3 Boiler control unit CPREG

Sophisticated digital boiler control unit **CPREG** controls the burner in accordance with the need for heating and sanitary water. Characteristics of the boiler control unit CPREG: microprocessor control, bimetal safety thermostat, safety pressure switch, micro switch for lower boiler door, control unit which turns on and off the burner according to set temperatures and operation regimes, regulates pellet supply by the feeder, operation in winter or summer regime, boiler protection against condensation, display the boiler current status on the screen, error messages on the screen, with boiler sensor and sanitary water sensor supplied.

Operation and setting of individual parameters are described in details hereinafter.

2.4 Pellet feeder CPPT

From tank to the burner pellets are transported by a pellet feeder **CPPT**. The feeder tube contains an Archimedean spiral which, with the assistance of an electric motor with gearbox, conveys pellets from the tank to the burner via a flexible tube. Electric motor is factory wired and it has to be connected to a connector at the rear side of the boiler control unit CPREG. If a power cable is damaged, its replacement should be done by an authorized service man or a person trained for such works in order to avoid risk of electric shock or damage of equipment.

2.5 Pellet tank CPSP

Pellet tank **CPSP** shall be located to the right (recommended) or left side, next to the boiler. After it has been positioned, a pellet feeder should be installed into the tank. Before filling of the tank, it is necessary to open the lid on the tank top and check whether the tank is free from solid objects or any other foreign objects which should not be there. Assembly of the pellet tank is described in assembly instructions of the pellet tank.

3. Component description and technical information

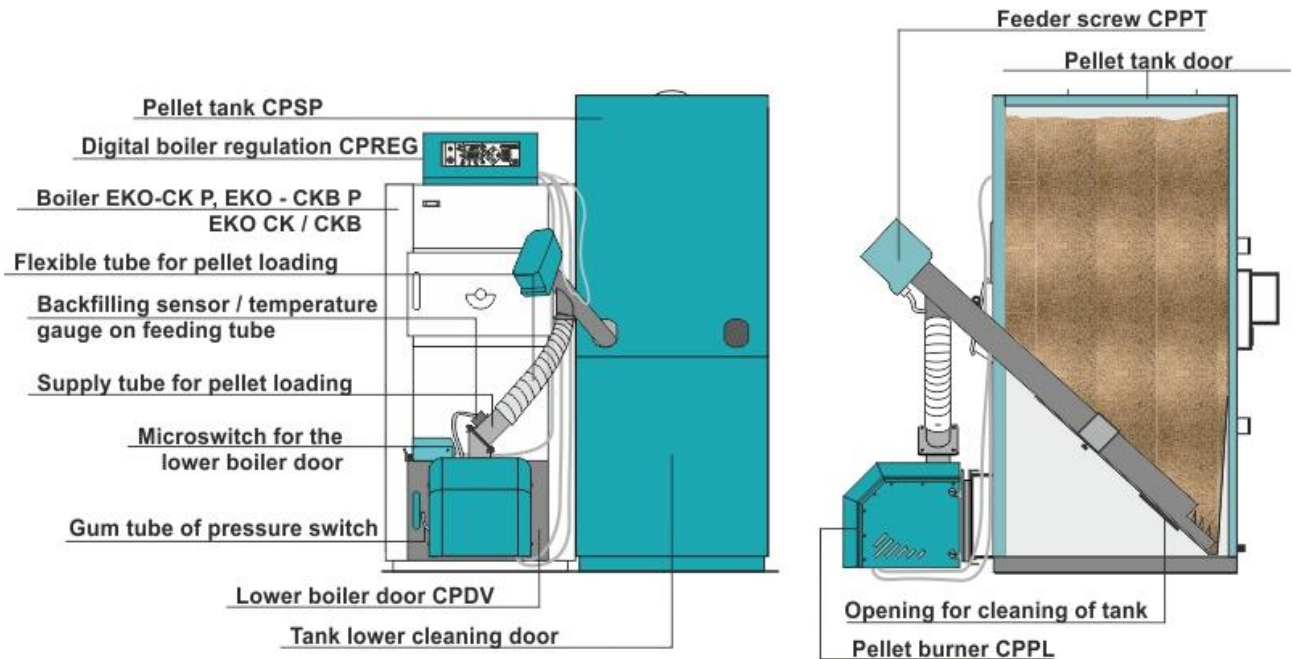

Cm Pelet-set type		40	50
Burner CPPL type		CPPL-50	CPPL-50
Set thermal output	(kW)	40	50
Boiler type		EKO-CK P / EKO-CKB P 50	EKO-CK P 60
Pellet tank volume	(l)	370	
Pellet tank height	(mm)	1545	
Pellet tank depth	(mm)	730	
Pellet tank width	(mm)	625	
Supply voltage	V/Hz	230/50	
Boiler width	(mm)	620	620
Lower boiler door CPDV	(mm)	CPDV for EKO-CK P / EKO-CKB P 50, EKO-CK P 60	

4. Safety components

The burner is equipped with several safety mechanisms:

Backfilling sensor / temperature gauge on inlet tube that is installed tube for connecting of pellet feeding flexible tube. At excessive temperature on feeding tube error E3 is displayed at control unit (LED diode ⚠ switched on). At backfilling supply tube error E9 is displayed at control unit (LED diode ⚠ switched on).

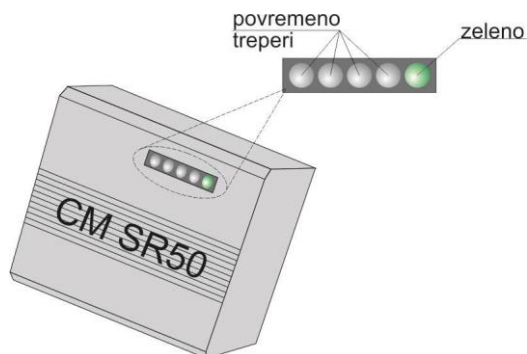

Backfilling sensor in normal mode (green LED flashing while the other depending on the amount of pellets that fall through the supply tube)

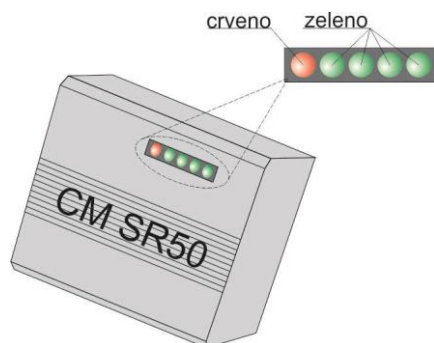

Backfilling sensor in a mode where the registered supply pipe backfilled with pellets (all LEDs light for 10 seconds without blinking, the regulation is displayed error E9)

- Safety pressure switch built in the burner controls overpressure in the boiler combustion chamber. If the set overpressure in the boiler combustion chamber is exceeded, pressure switch stops feeding of pellets, the burner shut down and the error E1 is displayed at control unit (LED diode ⚡ switches on).
- If lower boiler door are opened while the burner is working, micro switch on lower boiler door cuts the el. power to the control unit and burner. After closing the lower boiler door control unit continues to work according power supply interruption regime.
- If there is no flame (the built in photo-cell does not detect the flame within set time), control stops the burner operation and error E2 is displayed or it goes to blowing off and error E6 is displayed (LED diode ⚠ switches on).
- Control unit has a built in protective function which protects the boiler against overheating. If temperature in the boiler exceeds 93°C, regardless heating or sanitary water is needed the boiler pump and/or the sanitary water turns on and works until temperature in the boiler falls below 93°C.

When temperature in the boiler exceeds 110°C (+0°C / -9°C), power supply is turned off by the safety thermostat (via control unit).

Thermal protection built in coils of the fan electric motor at the burner and the screw feeder motor, protects them against overheating caused by failure or locking.

A flexible tube connecting the pellet burner and pellet tank is made of plastic material reinforced with metal wire which, in case of back flame from the burner to the tank, melts and prevents flame to penetrate to the pellet tank.

5. Fuel

Wooden pellets are used as fuel in boilers with built in Cm Pelet-set. Pellets are bio-fuel made of wooden wastes. Pellets can be stored in different ways: in bags of 15 kg, big bags of 1000 kg and in bulk form in large tanks (4 to 15 m³) dug in soil or located in basement premises. The recommended pellet properties for firing in Cm Pelet-set:

- Heating value ≥ 5 kWh/kg (18 MJ/kg)
- Diameter = 6 mm
- Max. length = 50 mm
- Max. moisture content = 12 %
- Max. dust content = 1.5 %.

3 m³ of pellets is equivalent to approx. 1000 litres of fuel oil.







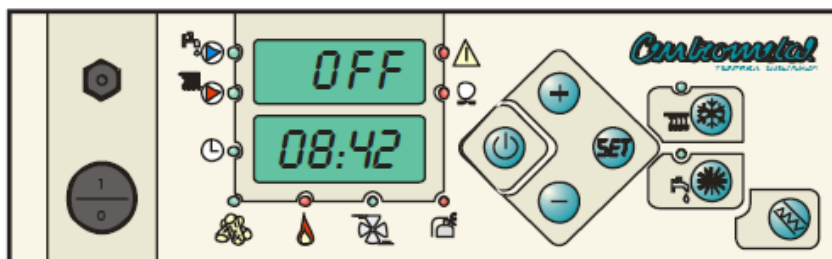

2 kg of pellet is equivalent to approx. 1 litre of fuel oil.

6. Boiler Control Unit









The boiler control unit is supplied in a plasticized metal box prepared for installation on boilers EKO-CK P and EKO-CKB P.



6.1 Description of buttons and symbols on the control unit

Button	Button function
	Safety thermostat button
	Main switch to turn on/turn off power supply to the control unit
	Start/stop button (on/Off) <ul style="list-style-type: none"> - By pressing the button for 3 sec. the burner turns on. - While the burner operates, by pressing the button for 3 sec. the burner goes to extinction phase. - Short pressing of the button: Exit from parameter setting and their saving
	Entry button to the parameter setting menu and going to the next parameter
	Setting of the selected parameter to higher value.
	Setting of the selected parameter to lower value.
	Selection of the WINTER firing regime. In this regime the heating pump turns on and a sanitary water pump also turns on if a sanitary water sensor is built in.
	Selection of the SUMMER firing regime. In this regime only the sanitary water pump turns on if a sanitary water sensor is built in. If it is a boiler with sanitary hot water heater inside the boiler water and if no sanitary water sensor is built in, neither the heating pump nor the sanitary water pump will turn on in the summer regime.
	Manual switch on of the pellet feeder. It is used to supply the feeder with pellets (after tank cleaning, tank discharge...).

6.2. Symbol description







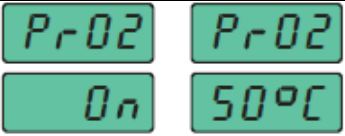
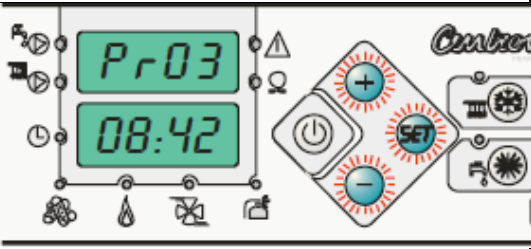
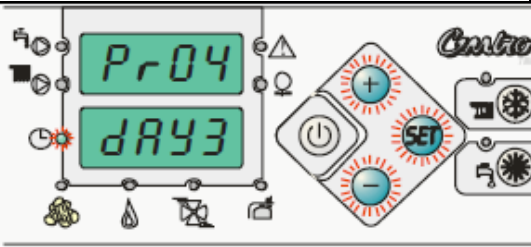

	Indication of operation of the sanitary water heating pump.
	Indication of operation of the heating pump circuit.
	Indication of turn on status of timer (time programmes).
	Indication of operation of pellet feeding screw feeder.
	Indication of flame presence in the burner.
	Indication of operation of the burner fan.
	Indication of operation of electric heater (for firing of pellets).
	An indication of activation errors except errors of safety pressure switch.
	Indication of the safety pressure switch due to too high pressure in the boiler combustion chamber.

6.3. Starting display and sanitary water temperature

	<p>Switching on the control unit</p> <p>By switching on the control unit via the main switch, the control is in OFF mode, i.e. the burner does not operate. OFF is displayed in the upper display, and current time and current temperature in the boiler are written in the lower display.</p>
	<p>Indication of the current sanitary water temperature</p> <p>If the sanitary water sensor is connected to the control unit and Pr02 is set to ON, by pressing and keeping pressed + button, in any operation mode or stand-by mode, the current temperature of sanitary water is displayed on lower display.</p>

6.4. Setting of the burner operating parameters

	<p>Setting of the burner operating parameters can be done in any operating mode (ON mode) or stand-by (OFF mode) of the burner.</p> <p>By longer pressing of SET button the parameter setting menu is entered, and by short pressing of SET button you can switch from menu to menu.</p> <p>Exit from a menu to home display and saving of modified values is made by short pressing of On/Off button or by passing through all 8 parameters and returning to the home display.</p> <p>If no button is pressed for 90 seconds, the control unit exits from a menu to home display without saving of modified parameters.</p>
	<p>Pr01: Boiler set temperature</p> <p>Factory setting for winter firing regime: 80°C. Factory setting for summer firing regime: 65°C. Available setting: min. 65°C; max. 90°C.</p> <p>The boiler set temperature can be changed by pressing + or - buttons.</p> <p>By SET button you go to other menu; Pr02.</p>
	<p>Pr02: Enabling heating of sanitary water in tank (not built in the boiler (located next to the boiler))</p> <p>Factory setting: OFF – sanitary water heating switched off.</p> <p>Available setting: ON (turned on) and OFF (turned off).</p> <p>In order to be able to turn on this function, it is necessary to have a built in sanitary water sensor (to connector 4). By pressing of + and - buttons sanitary water heating is turned on (ON) or turned off (OFF).</p>

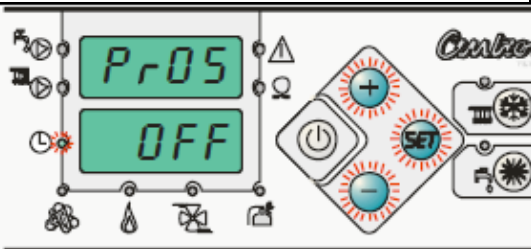
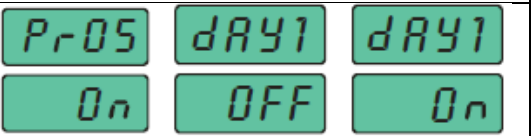

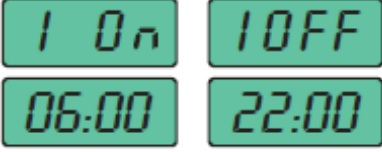
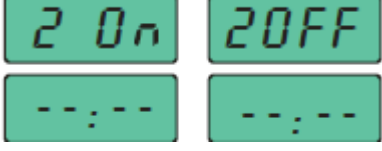
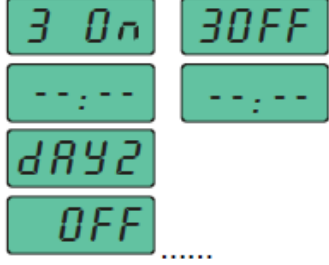
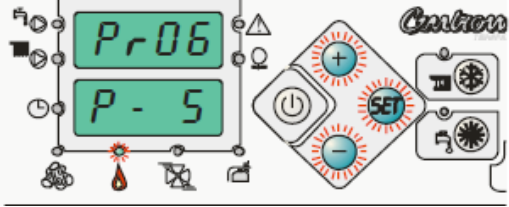
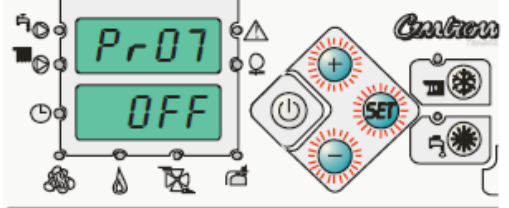
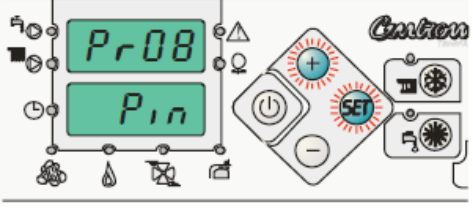

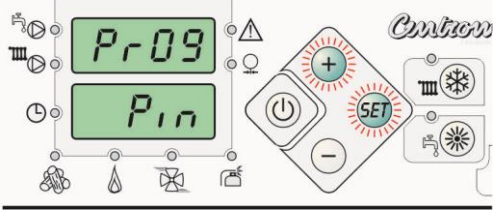
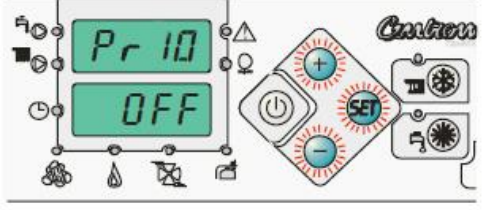
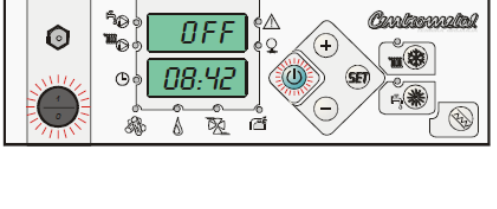
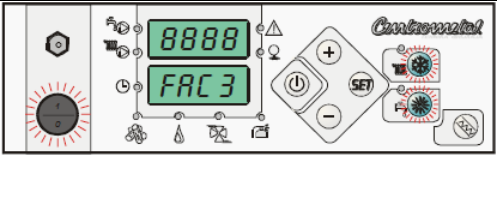
	<p>By putting of Pr02 to ON and by pressing SET button we enter sub-programme Pr02.</p>
	<p>Sub-programme Pr02: Sanitary water set temperature</p> <p>Factory setting: 50°C Available setting: min. 40°C; max. 80°C</p> <p>If is inbuilt sanitary water sensor and Pr02 on ON, sanitary water set temperature can be changed with buttons + and -. By SET button you go to other menu; Pr03.</p>
	<p>Pr03: Digital clock setting</p> <p>By entering Pr03 menu digital clock figure starts flashing which can be set by + and - buttons. By pressing of SET button the minute figure starts flashing. Correct value is set by + and - buttons and confirmed by pressing SET button.</p>
	<p>Pr04: Day setting</p> <p>Pr04 programme enables setting of a day of a week (important for correct functioning of activating times).</p> <p>DAY 1 = Monday (LED diode switches on ) DAY 2 = Tuesday (LED diode switches on ) DAY 3 = Wednesday (LED diode switches on ) DAY 4 = Thursday (LED diode switches on ) DAY 5 = Friday (LED diode switches on ) DAY 6 = Saturday (LED diode switches on ) DAY 7 = Sunday (LED diode switches on )</p> <p>Next menu Pr05 is entered by SET button.</p>
	<p>Pr05: Setting activating times (timer)</p> <p>Factory setting: OFF (turned off) Available setting: ON (turned on) and OFF (turned off).</p> <p>Activating times enable independent burner operation according to set activating times and days of a week. 3 ON times and 3 OFF times can be set in each day of a week. Minimum length of one activating time is 1 hour, and minimum period between off time and next on time is 1 minute. ON and OFF times may not overlapped.</p>
	<p>Sub-programme Pr05: Setting activating time</p> <p>Factory setting: DAY1=OFF, DAY2=OFF, DAY3=OFF... (all days off).</p> <p>Available setting: ON (turned on) and OFF (turned off) for each day separately.</p> <p>If setting activating times is turned one (ON), you may select a day on which we want to activate on times.</p>

	<p>For example, if we wish to turn inactivating time for Mondays, we have to change DAY1= OFF (by “+” or “-” buttons) to DAY1=ON and then press SET button.</p>
	<p>Sub-programme Pr05: Setting 1st activating time</p> <p>“1 On” refers to the first firing time, factory set to 06:00, and “1 OFF” means the first burner extinction time, factory set to 22:00.</p>
	<p>Sub-programme Pr05: Setting 2nd activating time</p> <p>Next menu “2 On” refers to the second firing time, factory turned off (- - : - -), and “2 OFF” means the second burner extinction time, factory turned off (- - : - -). For turning on the second activating time, the first burner shut-time must be shorter at least 1 minute than the second burner firing time.</p>
	<p>Sub-programme Pr05: Setting 3rd activating time</p> <p>Next menu “3 On” refers to the third ignition time, factory turned off (- - : - -), and “3 OFF” means the third burner extinction time, factory turned off (- - : - -). For turning on the third activating time, the first and second burner shut-times must be shorter at least 1 minute than the third burner firing time. By next pressing of SET button we move to the next day, DAY2 = OFF.</p>
 <p>Burner CPPL-50</p>	<p>Pr06: Setting of burner output CPPL-50</p> <p>Factory setting: P-5 Programme meaning: P-5 40 kW P-6 50 kW</p> <p>Burner output has to be set by + and – buttons <u>in accordance with the boiler output.</u></p>
	<p>Pr07: Turning on anti-frost programme (allowed to be used only if a room thermostat is connected)</p> <p>Factory setting: OFF (switched off) Available settings: “On” (turned off) and “OFF” (turned on).</p> <p>If anti-frost programme is turned on by pressing “+” button, and room thermostat is (obligatory) set to minimum, control unit will monitor temperature in the boiler and sanitary water tank and when it drops below +5°C, the burner will turn on and heat boiler to T_{set}.</p>
	<p>Pr08: Service menu, PIN (code) entry (only for servicemen)</p> <p>Factory setting: OFF (switched off)</p> <p>Available setting: Pin (switched on) If “+” button is pressed, “Pin” appears in the lower screen and PIN (enabling us to enter the service menu</p>

	<p>for setting of burner parameters) can be entered. By SET button we exit Pr08.</p>
	<p>Pr09: Service menu, PIN (code) entry (only for servicemen)</p> <p>Factory setting: OFF (switched off)</p> <p>Available setting: Pin (switched on) If "+" button is pressed, "Pin" appears in the lower screen and PIN (enabling us to enter the service menu for setting of burner parameters) can be entered for the basic configuration software. By SET button we exit Pr09.</p>
	<p>Pr10: Additional equipment, Pellet suction system</p> <p>(This parameter is visible only when service man install and turn ON pellet suction system. For detailed description see technical instructions for installation and use of pellet suction system.)</p>
	<p>Forced burner shut down</p> <p>If forced burner shut down is needed for any reason, and without standard extinction phase, it can be done by shut down of control unit at the main switch with simultaneous pressing of On/Off button. Control unit is then in OFF mode, i.e. burner is shut down. If control unit experiences any error after forced shut down, and if such error is not corrected and resetting was not performed, control unit will return to error mode. Depending the phase during which forced extinction was made, burner and grate must be thoroughly cleaned.</p>
	<p>Control unit resetting to factory settings</p> <p>To reset to factory settings control unit has to be turned off on the main switch, and then WINTER and SUMMER buttons have to be pressed simultaneously and keep them pressed while the main switch is being turned on. Four eights (8888) are displayed in the upper display, and FAC X (X denotes the currently set programme) are displayed in the lower display, and after that both displays resume their original settings: OFF is displayed in the upper display, and current time/boiler temperature are displayed in the lower display.</p>

7. Burner operation

7.1 Procedure of the first firing

1. Fill tank with pellets.
2. Check if all required connectors are connected to control unit and burner.
3. Check whether there is a grate and front cover in the burner head and whether the grate is positioned beneath the electric heater.
4. Check if the lower boiler door is closed and if micro switch is pressed with lower boiler door.
5. Plug in the boiler control unit into the mains outlet and press main switch to 1, check whether OFF appeared on the upper display and current time/current temperature in the boiler on the lower display.
6. Disconnect pellet feeding flexible tube from the burner and put a receptacle beneath it. Press button for filling the  feeder with pellets and keep it pressed until the feeders is filled up, i.e. until pellets start dropping from the flexible tube (it can take 5 to 10 minutes, depending on pellet type). Instead of pressing the pellet filling button, you can disconnect connector (1) from control unit and connect it with the cable connector (2) of electric motor supplying 230 V to electric motor of feeder. Wait until pellets start dropping from the tube and then disconnect connectors of electric motor and power supply.
7. Connect again pellet feeding flexible tube to the burner (and put connectors (1) and (2) into connectors at the boiler control – if they have been disconnected).
8. Select WINTER  or SUMMER  regime, as needed.
9. Select preferred parameters by pressing the SET button (meaning and selection of the parameters has been described in previous chapter) and set the correct output of the burner (Pr06) according to the boiler output.
10. Press ON/OFF button  3 seconds while “On” appears on upper display.
11. Flame will appear within 3 to 10 minutes (depending on the burner temperature and on quality of wooden pellets).
12. Depending on selected regime of factory setting temperature and depending the room thermostat is connected or not, pumps operate in the following way:
 - **“winter regime”**: heating pump and sanitary water pump (if sanitary water sensor is built in and Pr02 is “On”) turn on at min. 61°C and turn off at boiler temperature of 59°C. If the room thermostat is connected, it activates pumps as required in the room, provided the boiler temperature is min. 61°C and pumps turn off at boiler temperature of 59°C.
 - **“summer regime”**: (with tank outside the boiler, provided the sanitary water sensor and Pr02 is “On”) sanitary water pump turns on at boiler temperature of min. 61°C turn off at boiler temperature of 59°C.
 - **“OFF mode”** (main switch on; OFF on the upper display, burner is not working): heating pump and sanitary water pump (if the sanitary water sensor is installed and Pr02 is on “ON”) is starting to operate on 68°C, and switch off on 66°C, the room thermostat do not have the function.
13. In normal burner operation current boiler temperature will appear in the upper display and current time will appear in the lower display.
14. When the burner reaches set output (after approx. 8 to 15 minutes, depending on set power), and after the flame is stabilised, flue gases have to be analysed and, if necessary, to perform fine tuning of combustion parameters of the burner (it should be done by a professional or serviceman only).
15. After the set temperature is reached T_{set} (Pr01), control unit starts extinction (shut down) phase and the burner goes to stand-by phase, current boiler temperature is displayed in the upper display and OFF is displayed in the lower display.

7.2 Extinction procedure

Keep ON/OFF button  presses for 3 seconds, until OFF appears in the upper display. In that moment, pellet feeding is stopped, current boiler temperature appears in the upper display, OFF appears in the lower display, fan operates until flame is completely extinguished (or max.180 seconds). Afterwards, fan continues to work for certain period of time until the burner grate is blown off and then the burner is shut down, OFF appears in the upper display and current time/current time in the boiler appears in the lower display.



8. Control unit operation

8.1 Firing phase

After pressing ON/OFF  button for 3 seconds, ON appears in the upper display, followed by current temperature in the boiler, and current time appears in the lower display.

(If the boiler temperature is between T_{set} and $T_{set} - 5^{\circ}C$ at the moment of firing, current boiler temperature is displayed in the upper display and OFF is displayed in the lower display. When the boiler temperature drops below $T_{set} - 5^{\circ}C$, firing phase follows).

LED diode  at control unit turns on indicating fan operation which blows off the burner grate.

Pellet feed  and heater  turn on. Depending on the boiler output, i.e. burner, initial pellet feeding lasts 95 second and the heater continues working (safety time of 12 minutes starts from the beginning of pellet feeding). If no flame appears in that time, firing process is interrupted and error "E2" appears in the display. After pellet feeding is stopped, heater works until flame appears and control unit starts monitoring operation of the photo-cell. If photo-cell detects flame within the safety time (12 min.), heater will work for another 60 seconds and then it turns off.

After photo-cell has detected flame, control unit checks for 10 seconds whether flame is stabilized and

turns on indication  for presence of flame in the burner. Since that moment time required for good flame is running.

8.2 Transition phase

After pellets blaze up, transition phase of the burner operation starts wherein the burner output is increasing gradually to the set power. During that period proper basis for further pellet combustion is being prepared.

8.3 Operating phase

After transition phase ends, the burner starts to work at set parameters (set output).

Operation in winter regime :

Control unit monitors boiler temperature and, if necessary for heating (or room thermostat gives such instruction to the pump) and sanitary water, boiler temperature reached $61^{\circ}C$, heating pumps and sanitary water pump turn on (if sanitary water is enabled). If boiler temperature drops below $59^{\circ}C$, pumps turn off (regardless the needs). When the boiler reaches temperature of $T_{set} - 4^{\circ}C$, control unit reduces the burner output for 2 stages (e.g. from P6 to P4), and if temperature continues to rise and reaches temperature $T_{set} - 2^{\circ}C$, control unit will again reduce the burner output by 2 stages (e.g. from P4 to P2) and, when the boiler reaches temperature of T_{set} , the burner starts extinction procedure. If the boiler reached $T_{set} - 4^{\circ}C$, but it cannot reach temperature $T_{set} - 2^{\circ}C$ within 3 minutes the burner returns to set output and, when boiler reaches temperature $T_{set} - 2^{\circ}C$, control unit will reduce burner output by 2 stages. If in that operating regime boiler does not reach temperature T_{set} within 2 minutes, the burner resumes to set output and at temperature T_{set} the burner the burner starts extinction procedure. The burner re-ignites when the boiler temperature drops below $T_{set} - 5^{\circ}C$.

Operation in summer regime  :

a) With sanitary water tank (next to the tank)

If we wish to use boiler for heating of sanitary water only, either in stand alone or wall mounted sanitary water tank and not to turn on the heating pump, summer regime must be turned on, sanitary water sensor must be connected (to connector 4 at the control unit box) and programme Pr02 must be enabled (On). In programme Pr02 preferred sanitary water temperature is set (40°C to 80°C) and set boiler temperature T_{set} is determined according to $T_{preferred\ sanitary} + 10^{\circ}C$ (min. boiler temperature is always 65°C). Hysteresis of sanitary pump operation is fixed, factory set to 5°C. Sanitary water pump always turns on at boiler temperature of min. 61°C and turns off at 59°C. The burner works according to the set operation regime until it reaches $T_{preferred\ sanitary} + 10^{\circ}C - 4^{\circ}C$ when control unit reduces the burner output by 2 stages and, if temperature continues to rise and reaches temperature $T_{preferred\ sanitary} + 10^{\circ}C - 2^{\circ}C$, it reduces again the burner output by 2 stages and, when the boiler reaches temperature $T_{preferred\ sanitary} + 10^{\circ}C$ burner starts extinction phase. If the boiler reaches $T_{preferred\ sanitary} + 10^{\circ}C - 4^{\circ}C$ but it cannot reach temperature $T_{preferred\ sanitary} + 10^{\circ}C - 2^{\circ}C$ within 3 minutes, the burner resumes to the set output and, when the boiler reaches temperature $T_{preferred\ sanitary} + 10^{\circ}C - 2^{\circ}C$ control unit reduces the burner output by 2 stages.

If in that operating regime boiler does not reach temperature $T_{preferred\ sanitary} + 10^{\circ}C$ within 2 minutes, the burner resumes to set output and at temperature $T_{preferred\ sanitary} + 10^{\circ}C$ the burner the burner starts extinction procedure. The burner re-ignites when the boiler temperature drops below $T_{preferred\ sanitary} + 10^{\circ}C - 5^{\circ}C$.

Operation in summer regime  :

b) With a boiler with sanitary hot water heater inside the boiler water

If we wish to use boiler only for heating of sanitary water in the sanitary hot water heater in the boiler water, and not to turn on heating pump (and sanitary water pump – which, in this case, is not needed), summer regime must be turned on without connected sanitary water sensor. Programme Pr02 must be turned off (OFF). Sanitary water temperature is set by boiler temperature (i.e. sanitary water temperature will be equal to boiler water temperature). The burner works under winter regime, except heating pump and sanitary water pump do not turn on.

8.4 Extinction phase

After reaching set temperature of the boiler, the burner starts extinction phase – in manual operation it is done by pressing ON/OFF button, in automatic extinction it is done in accordance with set activating times and when errors E4, E5 and E6 occur.

In the beginning of extinction phase, pellet feeding is stopped, OFF appears in the lower display, and current boiler temperature appears in the upper display, fan works all the time the flame in burner is detected by the photo-cell (or max. 180 seconds). After that fan work for another 120 second to blow off the grate and prepare it for next firing.

8.5 Operation with timer

Control unit can automatically switch on and off the burner according to set weekly and daily programmes. Precondition for proper functioning of the burner with timer is correctly set current time and day of a week.

Three turns on and three turns off can be planned per day of a week. All activating times are factory set to off. For turning on of activating time see *Setting of the burner operating parameters*. For proper and efficient burner operation minimum burner work time is 1 hour, and min. stand-by time between two activating times is 1 minute.

8.6 Frost protection programme, allowed to use only if the room thermostat is connected

If we want to maintain minimum temperature (+5°C) in the boiler and sanitary water tank (if Pr02 is On) and minimum room temperature set at the room thermostat connected to the control unit, Pr02 programme has to be set to On. Main switch of the control unit must be in on mode, and control unit has to be in OFF mode (switched off).

The room thermostat must be connected to the control unit and set to minimum.

The burner turns on if the boiler temperature and/or sanitary water tank is below +5°C and/or an pulse is given by the room thermostat, and T_{boiler} is below 65°C, respectively. The burner turns off when the set boiler temperature is reached. The burner turns on again when the boiler and/or sanitary water tank temperature is below +5°C and/or an pulse is given by the room thermostat and

T_{boiler} is below 65°C, respectively. Heating pump turns on when a pulse is given by the room thermostat at $T_{\text{boiler}} > 61^{\circ}\text{C}$ or due to safety reasons (boiler overheating). If boiler $T_{\text{boiler}} < 65^{\circ}\text{C}$, and thermostat send a pulse, the control unit will turn on the burner and heat the boiler to T_{set} . If Pr07 programme is turned on (On), and boiler is OFF, Pr07 and OFF appear alternately in the upper display and current time and current boiler temperature are displayed in the lower display.

8.7 Boiler overheating protection

The control unit has a built-in protection which protects boiler against overheating. Regardless the operating regime (either winter or summer) and regardless the needs, the control unit turns on circulation pumps to cool the boiler.

In winter and summer regimes, if the boiler temperature exceeds 93°C, and regardless heating or sanitary water is needed, the boiler pump and/or sanitary water pump turns on and works until the boiler temperature drops below 93°C.

8.8 Flame extinction during operation

If during the firing phase flame appears and then disappears, the control unit will continue normal operation for next 4 minutes (till transition phase PP4) or 15 seconds (from transition phase PP4 to set programme) to recover the flame. If the flame does not appear, control unit goes back to the firing phase without pellet feeding until the flame is developed or, if flame does not appear in the safety time of 12 minutes, till error E2 appears.

If flame disappears during operation under set programme, after 15 seconds without flame the control unit goes to extinction phase and sent message on E6 error.

8.9 Power supply interruption

If power supply is interrupted while the burner is working (what can also occur because of opening the lower boiler door while the burner is working), after supply is re-established, On, 230 and T_{boiler} appear alternately in the upper display, and current time appears in the lower display, to indicate that the burner restarts after power supply is re-established. After power supply is re-established, the burner performs firing without pellet feeding (regardless flame is present or not, lasts 12 minutes) and then goes to extinction phase and On, 230 T_{boiler} appear alternately in the upper display and OFF appears in the lower display (regardless whether it should work or not). If, after completion of extinction phase, the burner should work, it goes to normal firing phase and, if the burner need not to work anymore, OFF appears in the upper display and current time and T_{boiler} appears in the lower display.

If, during the next burner start up, error E2 or E6 occur within time before the burner reaches the set programme, Err will be displayed in the upper display and E230 will be displayed in the lower display indicating that error could be caused by power supply interruption.

If the main switch turns off (or power supply is interrupted), during operation, the burner will, after main switch is turned on again, continue to operate under regime as in case of power supply interruption.

8.10. Operation of the regulation in "OFF" mode / boiler firing with solid fuel - not used for EKO-CK P boilers

Case a)

New models of boilers (doors can be rearranged to burn solid fuel or pellets)

Rearrange lower boiler door in reverse order from that described in the technical manual (EKO CK P/CKB P p.8) so that the door be converted to burn solid fuel, or buy additional door for combustion of solid fuels. The door mounted on the boiler and install the regulator drafts.

Case b)

Old models of boilers (must be installed doors for solid fuel combustion)

Remove the lower pellet door and pellet burner CPPL CPDV door and mount the lower door for solid fuel and install the regulator drafts.

When you have prepared the door, connect in the 6 - poles regulation connector which is unplug from the pellet burner (4 - poles regulation connector of the burner do not connect). Reverse the lid of the micro switch so You disable the operation of the micro switch (see next picture). Boiler regulation is obligatory to be switch on, on the main switch. On the upper display is shown "OFF" and on the lower is alternate the time and boiler temperature. In this operation time of the boiler regulation (if the antifreeze program in not switch on) the room thermostat is not active and the heating and sanitary water pump (if the sanitary water program parameter is switch on in the program Pr02 and the sensor for sanitary water is inserted) are switch on at the 68°C, and switch off at 66°C. If the regulation is not switch on (main switch on "0") the heating pump and sanitary water pump (if we have it) will not be in operation.

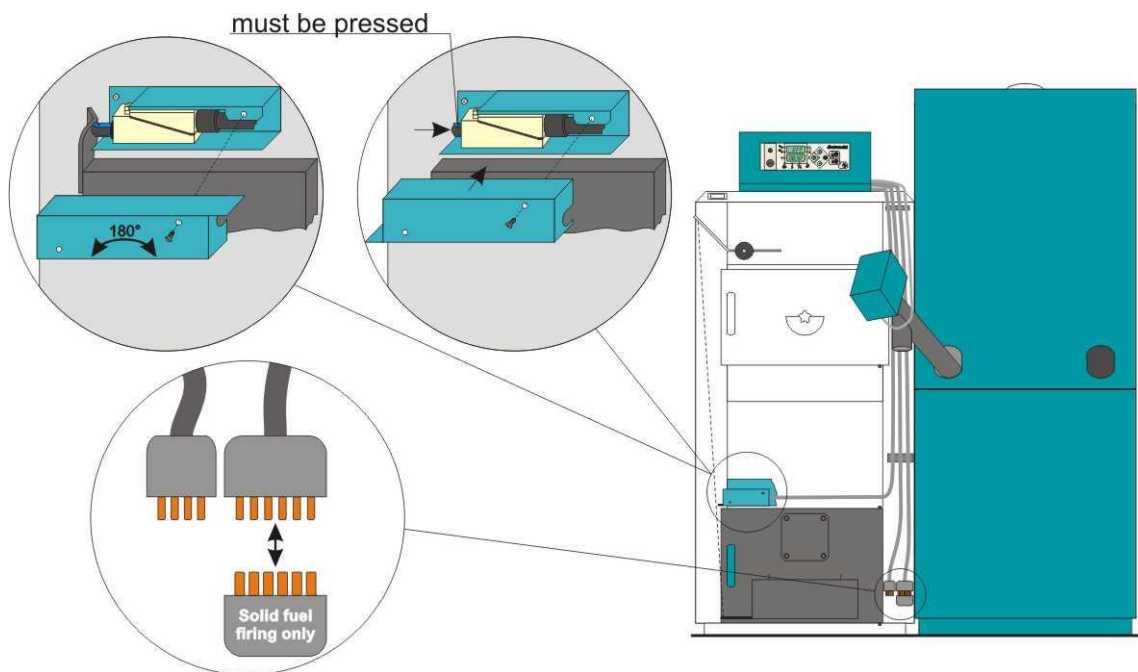

Solid fuel firing

9. Errors

Regardless the current operating regime of the burner, if errors E1, E2, E3, E7, E8, E9 and E230 occur, the control unit will stop operation immediately, while in case of errors E4, E5 and E6 burner goes to extinction phase. If control unit is in firing phase and flame has not occurred yet, due to notification on error, supply, fan and heater will be stopped immediately.

In case of error "Err" appears in the upper display and error type appear appears in the lower display and if it is also necessary to carryout extinction phase (in case of E4, E5 and E6 errors) "Err" appears in the upper display and "OFF" and error type appear alternately in the lower display.

- Error symbols:
- **E1** – safety pressure switch (LED diode Ω turns on)
 - **E2** – firing safety time expired
 - **E3** – excessive temperature on feeding tube (LED Δ turns on)
 - **E4** – boiler temperature sensor
 - **E5** – sanitary water temperature sensor
 - **E6** – flame disappeared
 - **E7** – error in memory
 - **E8** – interruption in fan operation
 - **E9** – backfilling supply tube with pellets
 - **E230** – signal of error E2 or E6 due to power supply interruption

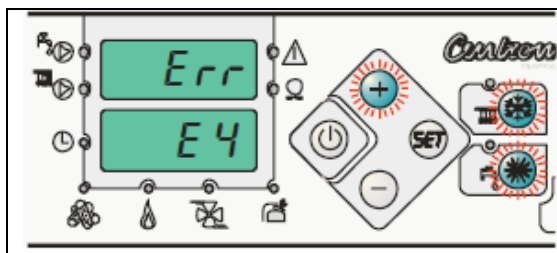

To enable control unit to resume to normal operation, error must be corrected and cancel it on the control unit. Error is cancelled by simultaneous pressing **WINTER** and **SUMMER** buttons and "+" button. If the error cause is not repaired, error cannot be cancelled.

9.1. Errors and possible causes

ERROR	CAUSE	WHAT TO DO
E1 – safety pressure switch	Too high resistance in combustion chamber	Check: How much is filled the boiler combustion chamber with ash, registers, flue gas tube and chimney; whether the pipe between pressure switch and boiler door is pressed. ,
E2 – firing safety time expired	Flame does not occur within safety time (12 min.)	Check whether: there are pellets in pellet tank; there are pellets in pellet screw feeder; pellet feeder flexible tube has slope toward the burner so pellets can drop freely into the burner; the burner grate is located correctly in the burner (that it does not rest ON electric heater); pellets are not too moist; pellets are of appropriate size (for these burner setting they should have diameter of 6 mm); hot air blows from the burner (i.e. whether electric heater has not blown); the photocell sensor is clean.
E3 – excessive temperature on feeding tube	Pellet feeding tube temperature at burner above 80°C	Possible fan stoppage. Possible filling up of the burner combustion chamber and feeding tube due to wrong set of combustion air, wrong set parameters of charge, inadequate size or quality of pellets, incorrectly set air in combustion chamber. Inappropriate pellet size and quality. Possible hole in flexible tube or disconnection of flexible tube from feeding tube. possible delays fan.
E4 – boiler temperature sensor	Error in boiler temperature sensor	Check sensor position. Check damages of sensor and cables. Check contacts on connectors.
E5 – sanitary water temperature sensor	Error in temperature sensors in sanitary water tank.	Check sensor position. Check damages of sensor and cables. Check contacts on connectors.
E6 – flame disappeared	Photocell does not detect flame in the burner combustion chamber.	Due to lack of pellets, feeding of too moist pellets, or due to dirty photocell.
E7 – error in memory	Memory failure	Resetting of control unit to factory setting is required.
E8 – fan malfunction	Sensor of revolution number does not “see” fan rotation	Due to failure of rpm sensor, due to failure of fan bearings (check whether it can rotate freely), due to entrance of foreign object into the fan rotor, due to activation of fan overheating protection (after cooling down by 30°C fan can be restarted).
E9 – backfilling supply tube with pellets	Backfilling supply tube with pellets	Check the burner grate fill, burner combustion chamber, combustion chamber of the boiler, flue gas tube and chimney, is the burner grate is properly placed in the burner (that is not set to the electric heater), whether the pellets are moist, not properly size or quality of pellets (for these burner settings is properly diameter of 6 mm), possible holes in a flexible tube, incorrectly configured parameters of charge, incorrectly adjusted air combustion.

<p>E230 –error E2 or E6 due to power supply interruption</p>	<p>Due to power supply interruption in safety time (12 min.) flame did not occur or photocell does not detect flame in the burner programme before reaching the set programme</p>	<p>Check filling up level of the burner grate, burner combustion chamber and check possible methods to eliminate errors E2 and E6.</p>
---	---	--

10. Connectors at the control unit box

At outer side of the control unit box there are connectors for connection of the control unit with sensors, pumps, burner and power supply network. Figure shows connectors arrangement and their purpose.

Figure: Connectors at the control unit box

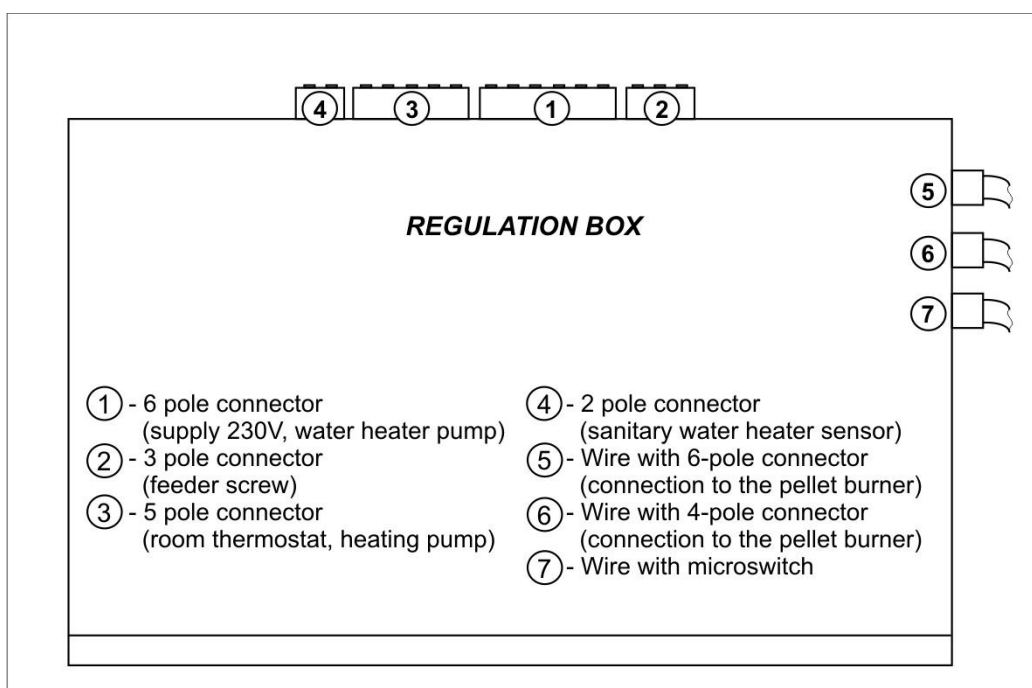

11. Maintenance of Cm Pellet-set

It is recommended to clean the burner and boiler combustion chamber after each consumed pellet tank (approx. 200 kg).

If required, cleaning frequency can be increased or reduced compared to the recommended one, depending on **quality of pellets** and frequency of the burner turning on/turning off.

- The following has to be checked:
- sediment in the boiler combustion chamber and clean it when required;
 - Ash in the burner combustion chamber (under the grate) – remove the burner cover to make cleaning easier (see figure).
 - sediment at burner grate and clean it when required;
 - ash amount in ash tray and empty it as required;

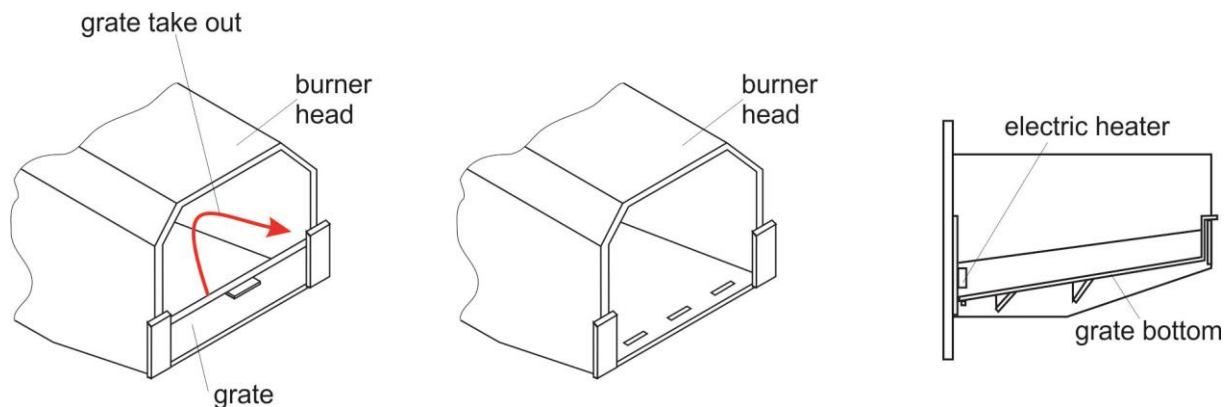

Removal of the front burner covers for easier cleaning and correct grate position

The following components must be thoroughly checked/cleaned:

- Clean thoroughly burner, grate...
- Clean photo-cell
- Empty and clean pellet tank
- remove and clean pellet feeder

Cleaning frequency of above items depends on pellet quality and it should be adjusted accordingly

- Check flexible connecting tube and place it so that flexible pellet feeding tube is inclined toward the burner so that pellets can fall freely into the burner,
- Check wires and connections and replace them when required.

12. The possibility of fan lid installing

Burners **CPPL-50** which have connectors for electrical connections built-in below burner cover, which power lines in safety rail to connectors are coming from burner bottom (see schemes in this manuals) not the through cover side of burner cover are factory predicted for subsequent installation possibility of fan lid.

Fan lid must subsequently fitted by authorized service by Centrometal with authorization for this type of product or Centrometal service.

Subsequent installation of fan lid include installation of fan lid assembly to burner, electrical wiring of burner and installation of electrical board with wiring to boiler control unit.

Subsequent installation can be done on place where is burner mounted or Centrometal factory.

With purchasing fan lid for subsequent installation are received all part which is needed to install.

Company shall not be responsible for possible incorrect data caused by printing errors or errors during transcription and in any case, it reserves the right to modify its products deemed to be required and useful, without any prior notification.