

Centrometal

HEATING TECHNIQUE

Centrometal d.o.o. - Glavna 12, 40306 Macinec, Croatia, tel: +385 40 372 600, fax: +385 40 372 611

ENG

TECHNICAL INSTRUCTIONS

installation, use and maintenance of the
hot water boiler
and installation of the additional equipment



EKO-CUP V3



These instructions are an integral part of this product. All rights reserved. Reproduction of content of this document and transfer to third parties is not allowed without written approval from manufacturer. Make sure that instructions are always with the device, even if it is sold/transferred to another owner, so user or authorized person for maintenance or repairs can consult it.



READ THESE INSTRUCTIONS CAREFULLY BEFORE INSTALLING THE BOILER TO HEATING SYSTEM!



Boiler must not be used by children or disabled persons (either physically or mentally), as well as by persons without knowledge or experience, unless they are under control or trained by a person responsible for their safety. Children must be supervised in the vicinity of the product.



Boiler must not operate in flammable and explosive environment.



Before any work on the boiler electric energy must be switched off.



Please note that the installation, startup and maintenance can be only performed by a qualified heating contractor or service organization. Any work on electrical and fuel carrying components must be done by a qualified service technician.

Explosive danger due to flammable fumes!

WHAT TO DO WHEN YOU SMELL SMOKE?



- Shut off main gas /oil supply!
- Open windows and doors!
- No open fire! Do not smoke! Do not use a lighter!
- Avoid generating sparks! Do not use a electrical switch, telephone, electrical socket or bell!
- Notify homeowner, but do not use a door bell or phone!
- Leave the building!
- Immediately, notify the gas or oil supplier from a remote location!
- If necessary, notify police or fire department.
- Immediately leave the building, when you hear or see gas leak!

Insufficient amount of fresh air for combustion in the boiler room can lead to dangerous conditions.

Make sure that the openings for combustion air supply are not reduced or closed.



Keep the boiler room door closed.

Protect the boiler room and avoid rodents and birds from entering and blocking the air openings.

If above mentioned issues are not solved, the boiler cannot be put into operation.

1.0. TECHNICAL DATA

TYPE	EKO-CUP V3	800	1000	1250	1500
Nominal heat output	(kW)	800	1000	1250	1500
Heat output range	(kW)	240-800	300-1000	375-1250	400-1500
Required chimney underpressure	(mbar)	0,03	0,03	0,03	0,03
Water amount in boiler	(l)	1020	1150	1410	1510
Exhaust gas temperature at nominal heat output	(°C)	160	160	160	160
Exhaust gas temperature at minimum heat output	(°C)	120	120	120	120
Boiler resistance on water side at nominal output (dT 10°C)	(mbar)	36	25	38	27
Resistance of the combustion chamber at 80% power output	(mbar)	4,15	4,60	5,4	6,3
Resistance of the combustion chamber at 100% power output	(mbar)	6,3	7,1	7,9	8,7
Fuel type		oil / gas			
Maximum heat input OIL/GAS	(kW)	850/850	1060/1060	1325/1325	1585/1585
Exhaust gas flow at 100% power output - OIL / GAS ^{*2}	(g/s)	-	518/455	732/680	-
CO ₂ content at 100% power output OIL / GAS ^{*2}	(%)	-	9,76/9,2	9,63/9,41	-
Combustion chamber dimensions	(mm)	fi700x1875	fi700x1875	fi825x1875	fi850x1875
Combustion chamber volume	(l)	721	721	1001	1001
Combustion chamber type		overpressure			
Gas volume of the boiler	(m ³)	1,01	1,12	1,46	1,48
Supply voltage	(V)	230			
Frequency	(Hz)	50			
Current type		~			
Total mass - (boiler with casing and accessories)	(kg)	2104	2320	2770	2950
Max. operating overpressure	(bar)	6			
Test pressure	(bar)	9			
Max. operating temperature	(°C)	90 / 100 / 105 ^{*1}			
Uptake tube - external diameter	(mm)	fi300	fi300	fi400	fi400
Efficiency on 30% power output OIL/GAS ^{*2}	(%)	94,76/94,08	94,74/94,09	94,60/94,17	94,45/94,24
Efficiency on 100% power output OIL/GAS ^{*2}	(%)	94,33/94,35	94,42/94,30	94,57/94,47	94,72/94,63



If you look carefully, in table above, you will see some labeled technical data (*n.). That label means possibility to order boilers with different characteristics. In table below is explained meaning of label.

*1	<p>DESCRIPTION: Boilers EKO-CUP V3 can be used to work with three different max. operating temperatures - 90°C, 100°C or 105°C, depending on the installed boiler controller.</p>
*2	<p>DESCRIPTON: Values given in the table are the test report values (No. 30-12644/T and No. 30-12643/T issued by SZU s.p., Brno, Czech Republic).</p> <p>FOEL: EKO-CUP V3 1000 with burner Giersch M312-Z-L-SD EKO-CUP V3 1500 with burner Giersch M3.22-Z-L</p> <p>GAS: EKO-CUP V3 1000 with burner Giersch MG3.1 EKO-CUP V3 1500 with burner Giersch MG3.3</p> <p>The efficiency values were interpolated between the boiler and burner combinations that had been tested.</p>

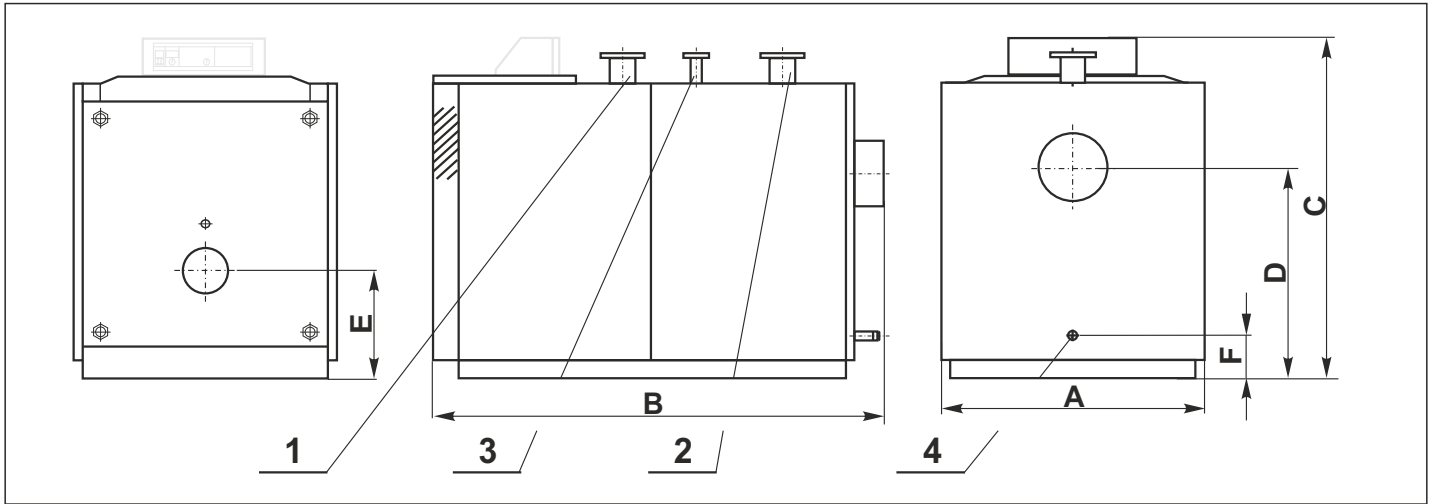

BOILER DIMENSIONS		800	1000	1250	1500
A Boiler width	(mm)	1365	1435	1585	1635
B Boiler length	(mm)	2465	2465	2465	2465
C Boiler height	(mm)	1775	1775	1955	2005
D Boiler flue exhaust	(mm)	1150	1220	1370	1420
E Burner opening	(mm)	660	660	765	763
F Filling / drainage	(mm)	225	225	275	275
1 Boiler return	DN	100	125	125	125
2 Main flow	DN	100	125	125	125
3 Safety line	R"	50	65	65	65
4 Filling / drainage	R"	5/4"	5/4	5/4	5/4

Boiler resistance on water side

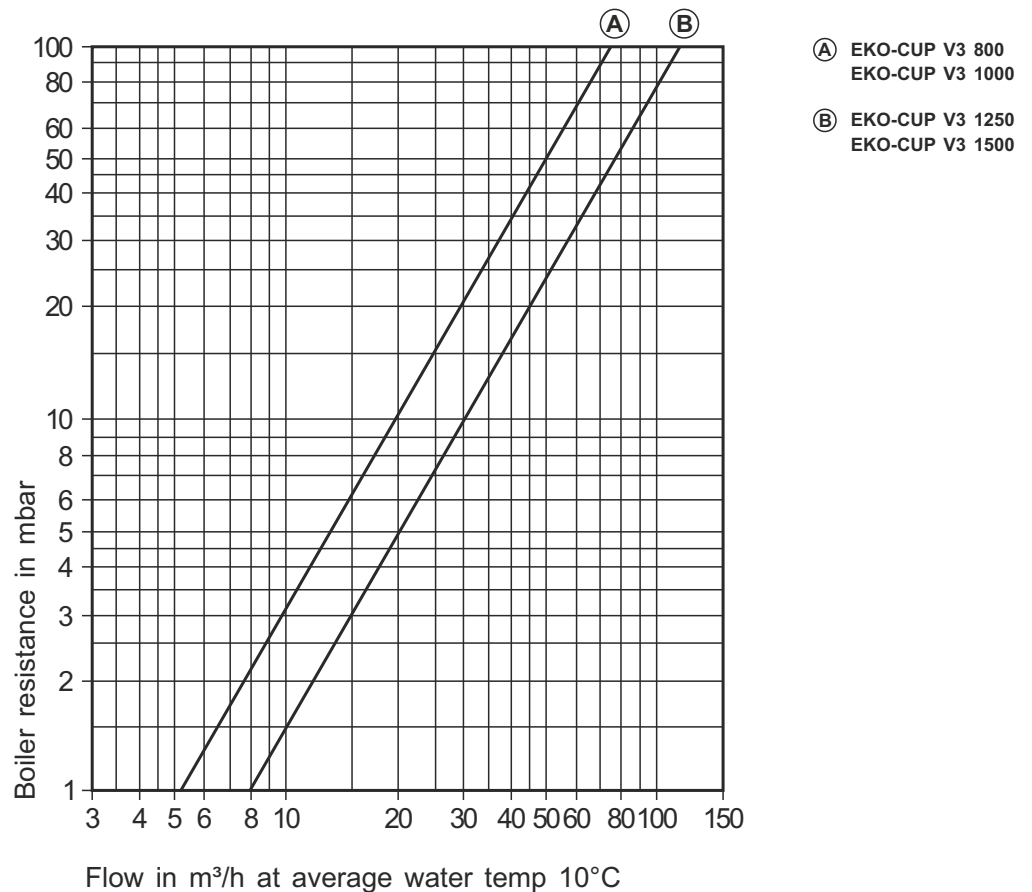

2.0. COMPONENT PARTS OF THE BOILER EKO-CUP V3

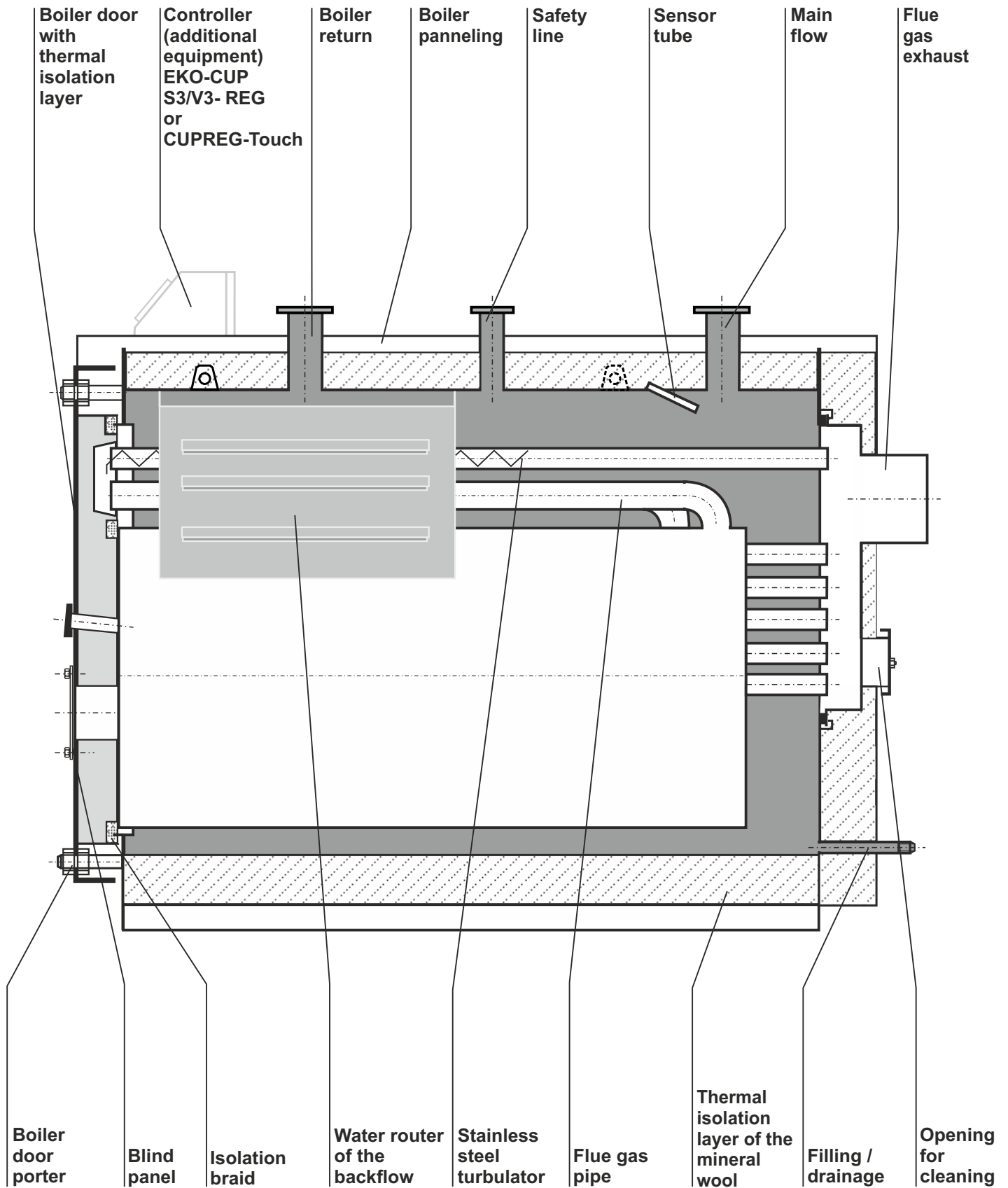

3.0. IN GENERAL

The boiler **EKO-CUP V3** for central heating is intended for firing with light heating oil and gas. The boiler has a modern construction and design regarding to the projected capacity. The boiler is made out of controlled high quality materials, welded with the most modern technology. EKO-CUP V3 boiler is approved and tested under EN norms and fulfills all special requests for the connection to the central heating system installation.

3.1. BOILER DESCRIPTION

EKO CUP V3 is 3-pass flue gas flow system steel hot water boiler. Flue gases flow from the combustion chamber into the tube of second pass into the tube of third pass in which turbulators are placed. The turbulators, which are in the tube chamber, enable longer maintaining of the flue gases, better transport of the heating energy to the water, and also for the fine regulation of the entrance temperature of the flue gases depending on the boiler load. The flue gases are collecting in the smoke chamber and drain off to the chimney.

4.0. BOILER DELIVERY

The boiler **EKO-CUP V3** is delivered together with outer boiler panelling made of plastificated sheet metal and thermal isolation of mineral wool and cleaning tool - cleaning brush.

OBLIGATORY ACCESSORIES (ORDERED ADDITIONALLY):

- Basic boiler controller EKO-CUP S3/V3- REG

or

- Basic boiler controller CUPREG-Touch

5.0. MOUNTING

The boiler **EKO CUP V3** is intended for mounting in the boiler room, which has to be built according to the thermal rated output of the boiler, normal operation conditions, undisturbed serving and easily accessible boiler, burner and boiler equipment. The boiler must be placed on the 5 to 10 cm high placement above the ground. Edges of the boiler placement must be protected by an iron made frame (50x50x5). The boiler must be positioned to enable supervision during boiler operation, cleaning and maintenance. Due to easier transport of the boiler into the boiler room, mounting of the thermal isolation has to be done after the boiler is properly placed in the boiler room as is shown on the Scheme 1.

Scheme 1: The boiler outer panelling assembly EKO CUP V3

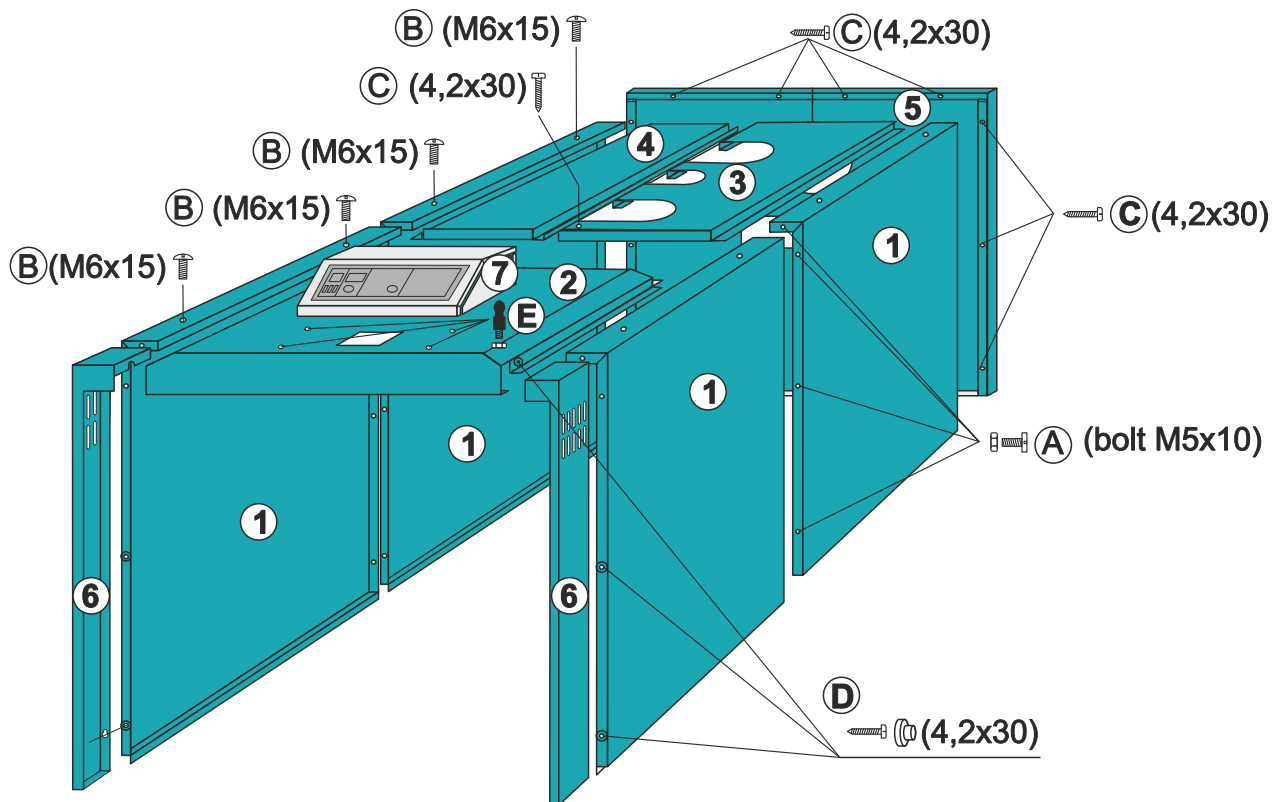

PROCESS OF THE PANELLING ASSEMBLY ON THE BOILER:

1. Envelope the insulation layer of the mineral wool over the outer cylinder of the boiler and fasten it with metal fasteners.
2. (VALID only if boiler controller EKO-CUP S3/V3- REG is installed on the boiler). On the upper front side (2) install the roots (E), which are used for the mounting of the boiler control panel (7).
3. The boiler probe for boiler controller sensors is located between the boiler flow and return lines.
 - a) If the boiler control EKO-CUP S3/V3 - REG is installed on the boiler, it is necessary to push the thermometer sensor, regulation thermostat and boiler controller safety thermostat into the boiler probe.
 - b) If the boiler control CUPREG-Touch is installed on the boiler, it is necessary to push the boiler temperature sensor and the safety thermostat of the boiler regulation into the boiler probe.
4. Upper front side (2) adjust on the upper insulation porters on the boiler.
5. Assemble the left and right lateral sides (1), each of the two parts with screws (A) (M5x10) and the lower end of the lateral sides (1) place in the grooves on the lower part of the boiler and fasten it to the upper side (2) with screws (B) (M6x15).
6. The back side which is made from two part (5) put together with the screws (C) (4,2x30) and adjust it on lateral sides (1) with screws (C) (4,2x30).
7. Upper side (3) adjust on the upper boiler porters. Do the same with the side (4) and fasten side (3) to the side (2) with screws (4,2x30).
8. Place the 4,2 x 30 screws with spacers (D) in the marked position and set the door protection (6) on them.
9. For the control panel electrical connection it is necessary to open the back lid on the control panel, on which the line clamp is positioned.

6.0. CHIMNEY

Precisely calculated and performed chimney is a precondition for safe boiler operation and economic heating results. The chimney must be well thermal isolated, gas-impermeable and smooth. On the lower part of the chimney a cleaning door must be installed. Walled chimney must be three-layered with a mineral wool isolation layer in the middle. The thickness of the isolation should be at least 30 mm if the chimney is mounted inside the building and 50 mm thick if is mounted outside building walls. The inner diameter of the chimney depends upon the actual chimney height and the boiler power output. **For the correct chimney selection, the sizing must be carried out according to the diagram on the Figure 1.** The flue gas temperature on the chimney exit has to be at least 30°C higher than the condensation temperature of the combustion flue gases.

Figure 1: Chimney dimensions for the pressurized boilers fired with oil or gas

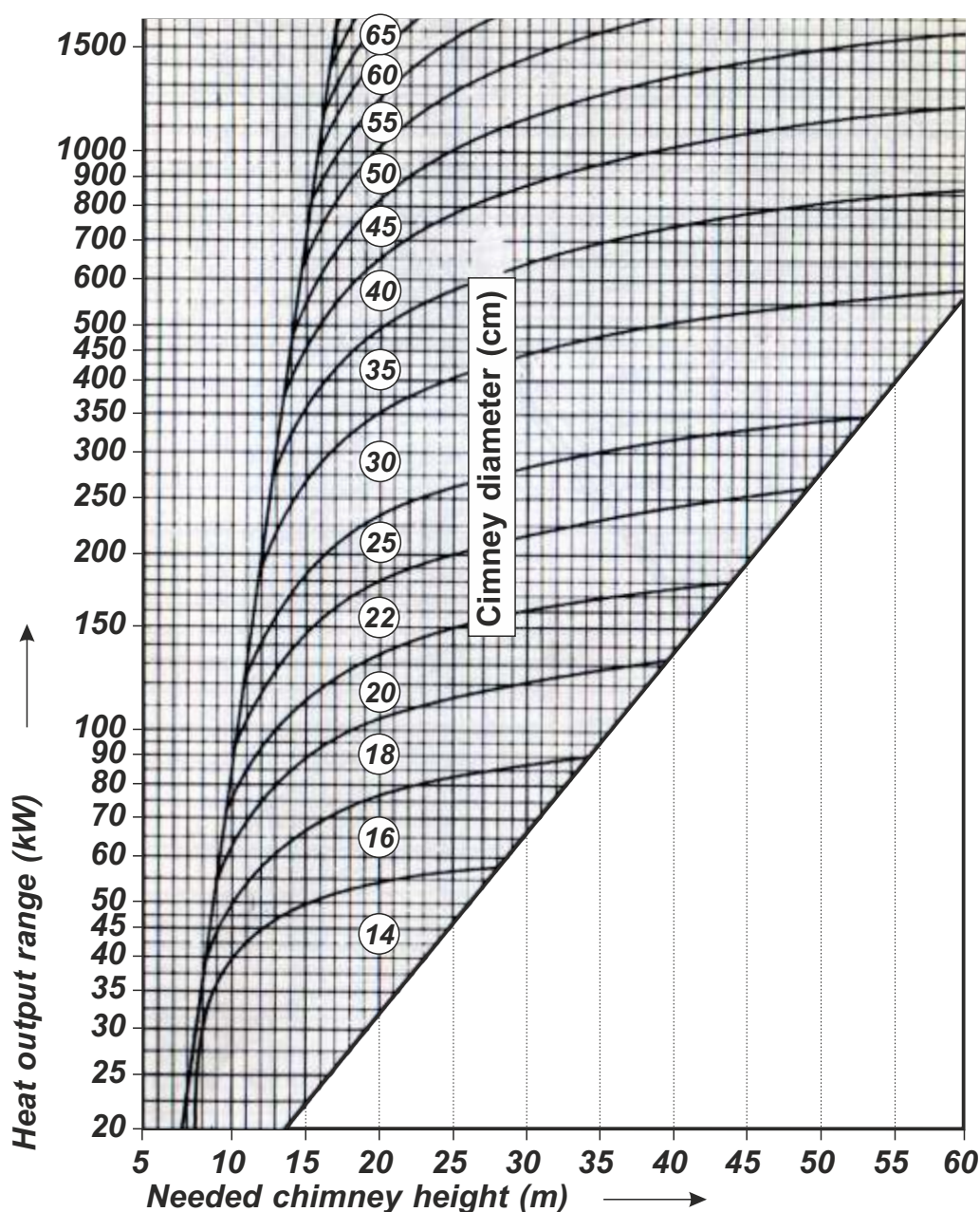

6.1. CONNECTION TO THE CHIMNEY

The flue gas tube (flue gas exhaust) between the boiler and the chimney has to be mounted under an inclination between 30 to 45°C (Figure 2). To prevent the entering of condensing fluid from the chimney into the boiler, it is necessary and important to mount the flue gas tube 10 mm deeper into the chimney. For easier flue gas tube cleaning the tube must have an opening (Figure 3). Connections of the flue tube on the boiler and chimney must be properly made and sealed. For easier chimney cleaning we recommend the distance between the boiler and the chimney or wall at least 600 mm.

Figure 2: Possible way to connect the EKO CUP V3 boiler to the chimney

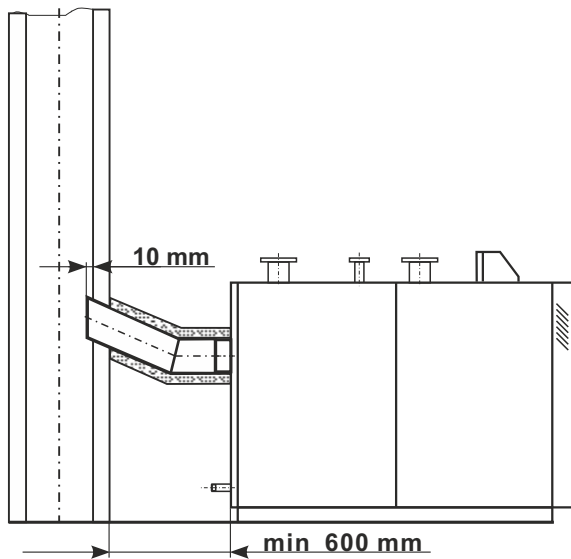
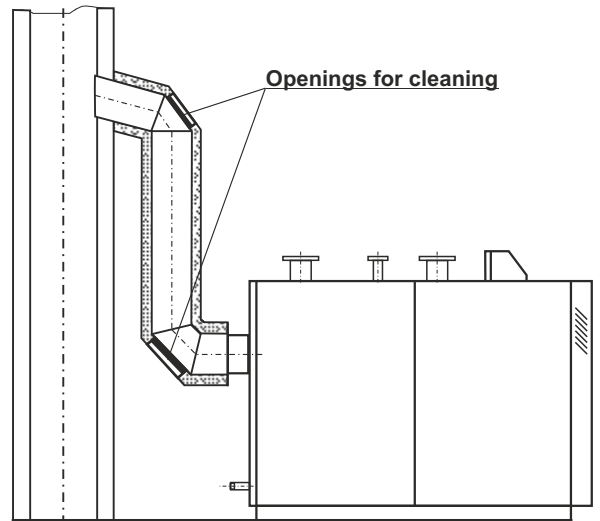

Figure 3: Possible way to connect the EKO CUP V3 boiler to the chimney



6.2. FRESH AIR OPENING

Every boiler room must have a correct calculated **opening for fresh air inlet** regarding to the boiler power output. The diameter of the opening for the air inflow is calculated:

$$A = 6.02 \cdot Q$$

A - surface of the opening in cm²

Q - boiler power output in kW

The opening must be protected by a net or grid.

7.0. CONNECTION TO THE INSTALLATION

All installation works must be done in accordance with valid national and European standards. Before boiler connection to the heating system installation it is necessary to clean all tubes in the system from dirt layers. This actions prevent boiler overheating, noise in the heating system, disturbances on the pump and mixing valve. Connection to the heating system must be performed with holenders to the thread connection with or without mixing valve to an open or closed system. In a closed heating system, it is obligatory to install certificated safety valve with opening overpressure set on 6,0 bar (depending on the configuration shown on the page 4). Security and expansion lines must not have any stop elements. Boiler water outlet from the safety valve is lead directly to the sewerage. During the water filling into the heating system it is necessary to open the mixing valve if it is inbuilt and to air-vent the boiler and the heating system. The boiler connection to central heating must be performed as shown on the Scheme 2 and in accordance with the norm EN 12828:2012+A1:2014.

7.1. WATER QUALITY

To prevent excessive limescale build-up of calcium carbonate on the boiler heating surfaces, its concentration must be below the permitted maximum values mentioned in the following table:

Boiler	Total alkaline earths mol/m ³	Total hardness °dH
EKO-CUP V3	< 0.02	< 0.11

Scheme 2: Hydraulic connection scheme

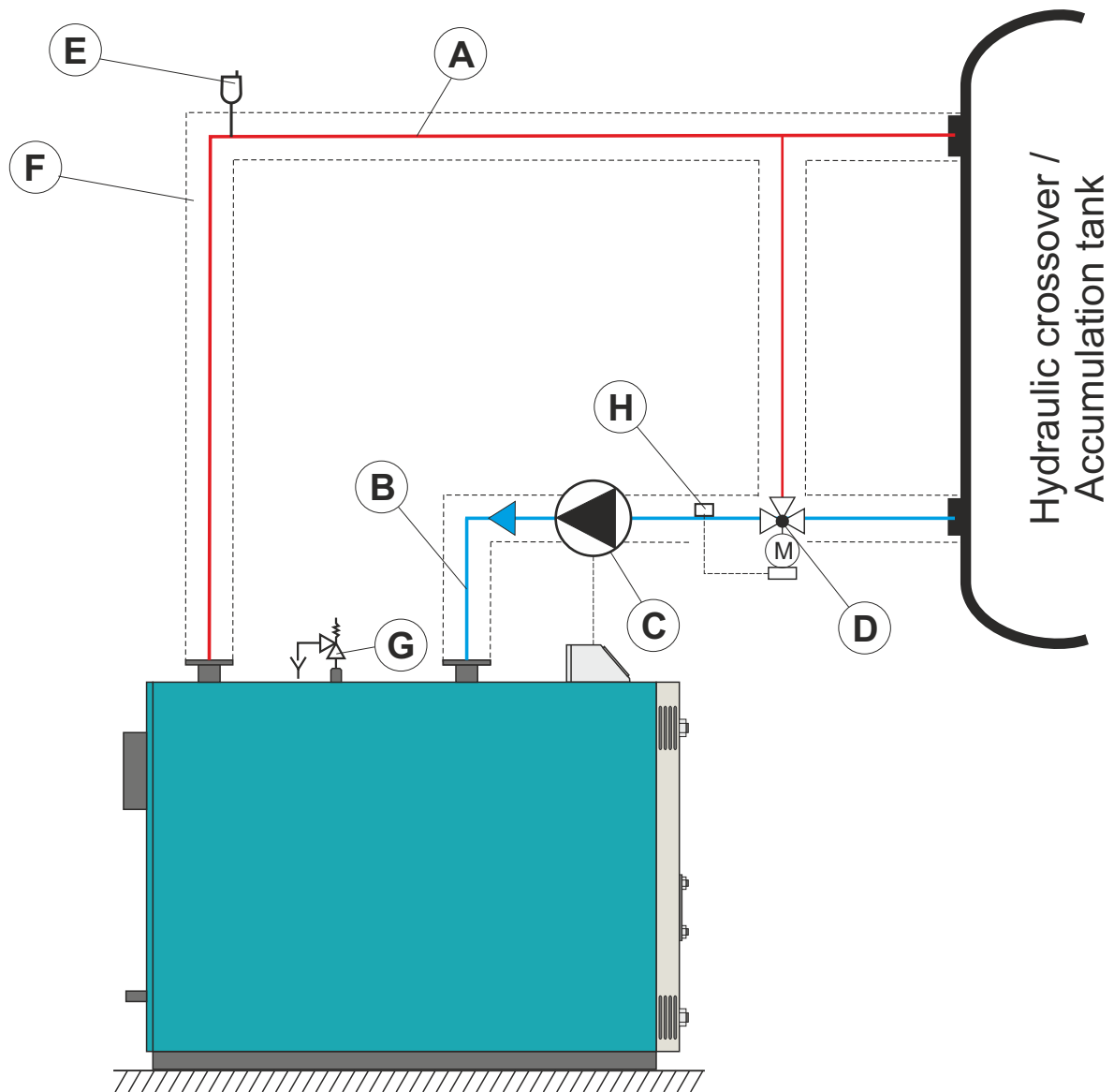

LEGEND:

- | | | |
|-----------------------------|---|---|
| A - Boiler flow | D - 3-way therm. motor mixing valve (if the basic boiler controller EKO-CUP V3/S3 - REG is installed on the boiler, it is necessary to additionally install a regulator + return temperature sensor) | F - Thermal insulation of the security line of the boiler |
| B - Boiler return | E - Automatic air vent point | G - Safety valve max. 6 bar (only at closed heating system) |
| C - Circulation pump | | H - Additional regulator flow temperature sensor for control 3-way valve with motor actuator (if the basic boiler controller EKO-CUP V3/S3 - REG is installed on the boiler) |

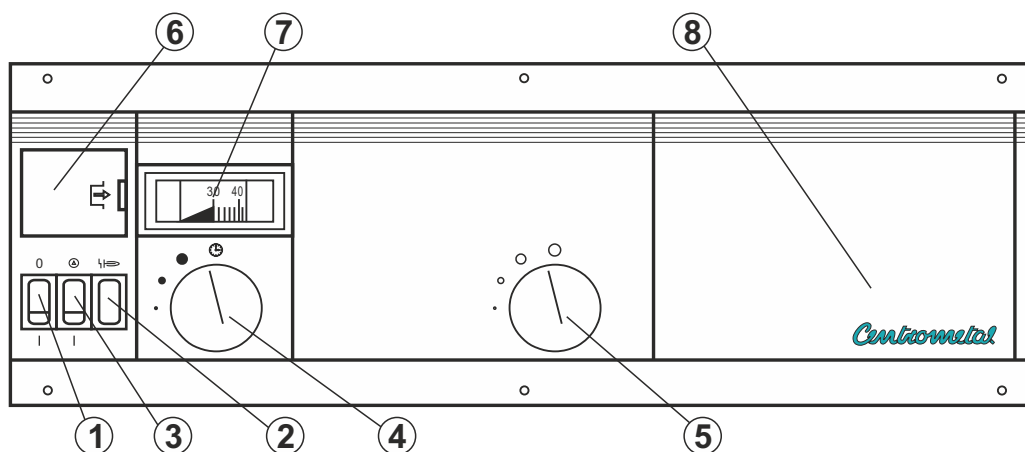

Hydraulic connection scheme must be performed in a manner as shown on this scheme. Other parts of installation, which are not shown on this scheme must be performed according to the norm EN 12828:2012+A1:2014.

8.0. BASIC BOILER CONTROLLER (ADDITIONAL EQUIPMENT)**8.1. BASIC BOILER CONTROLLER - EKO-CUP V3/S3 - REG (ADDITIONAL EQUIPMENT)****1. MAIN SWITCH**

Switch with a signal diode for turning the boiler ON and OFF.

2. BURNER CONTROL SIGNAL LIGHT

If there are disturbances during operation, this control signal light will light up.

3. CIRCULATION PUMP SWITCH

The switch for turning the circulation pump ON and OFF.

4. REGULATION THERMOSTAT FOR THE FIRST BURNER STAGE

Setting boiler operation temperature is achieved by turning the button.

5. REGULATION THERMOSTAT FOR THE SECOND BURNER STAGE

Setting boiler operation temperature is achieved by turning the button.

6. SAFETY BOILER THERMOSTAT

Stops the burner operation if the boiler water temperature would cross max. permitted temperature thus preventing any major breakdown. When the burner is put into the operation again, following steps must be taken:

- wait until the boiler temperature drops and reaches the value under 70°C
- take the safety lid off (Position ⑥)
- push the red button

If there are still frequent interruptions during the boiler work, it is necessary to contact the qualified person to check it out.

7. THERMOMETER

The thermometer indicates the boiler water temperature in °C.

8. POSITION FOR MOUNTING AUTOMATIC CONTROLLER

(additional equipment)

**8.1.1. BASIC BOILER CONTROLLER - EKO-CUP S3/V3 - REG - 90 °C
(ADDITIONAL EQUIPMENT)**

- see technical instructions delivered with the boiler controller - EKO-CUP S3/V3 - REG - 90 °C

**8.1.2. BASIC BOILER CONTROLLER - EKO-CUP S3/V3 - REG - 100 °C
(ADDITIONAL EQUIPMENT)**

- see technical instructions delivered with the boiler controller - EKO-CUP S3/V3 - REG - 100 °C

**8.1.3. BASIC BOILER CONTROLLER - EKO-CUP S3/V3 - REG - 105 °C
(ADDITIONAL EQUIPMENT)**

- see technical instructions delivered with the boiler controller - EKO-CUP S3/V3 - REG - 105 °C

8.2. BASIC BOILER CONTROLLER (additional equipment): CUPREG-Touch



controller CUPREG-Touch
(additional equipment)

**8.2.1. BASIC BOILER CONTROLLER (additional equipment):
CUPREG-Touch/90°C**

- see technical instructions delivered with the boiler controller CUPREG-Touch/90°C

**8.2.2. BASIC BOILER CONTROLLER (additional equipment):
CUPREG-Touch/100°C**

- see technical instructions delivered with the boiler controller CUPREG-Touch/100°C

**8.2.3. BASIC BOILER CONTROLLER (additional equipment):
CUPREG-Touch/105°C**

- see technical instructions delivered with the boiler controller CUPREG-Touch/105°C

9.0. CONNECTION OF THE BASIC BOILER CONTR. ON EL. INSTALLATION

9.1. CONNECTION OF THE BASIC BOILER CONTROLLER - EKO-CUP S3/V3 - REG - 90 °C ON EL. INSTALLATION

- see technical instructions delivered with the boiler controller - EKO-CUP S3/V3 - REG - 90 °C

9.2. CONNECTION OF THE BASIC BOILER CONTROLLER - EKO-CUP S3/V3 - REG - 100 °C ON EL. INSTALLATION

- see technical instructions delivered with the boiler controller - EKO-CUP S3/V3 - REG - 100 °C

9.3. CONNECTION OF THE BASIC BOILER CONTROLLER - EKO-CUP S3/V3 - REG - 105 °C ON EL. INSTALLATION

- see technical instructions delivered with the boiler controller - EKO-CUP S3/V3 - REG - 105 °C

9.4. CONNECTION OF THE BASIC BOILER CONTROLLER - CUPREG-Touch/90°C ON EL. INSTALLATION

- see technical instructions delivered with the boiler controller CUPREG-Touch/90°C

9.5. CONNECTION OF THE BASIC BOILER CONTROLLER - CUPREG-Touch/100°C ON EL. INSTALLATION

- see technical instructions delivered with the boiler controller CUPREG-Touch/100°C

9.6. CONNECTION OF THE BASIC BOILER CONTROLLER - CUPREG-Touch/105°C ON EL. INSTALLATION

- see technical instructions delivered with the boiler controller CUPREG-Touch/105°C

10.0. BURNER SELECTION

Burner must be suitable for the respective rated output as well as the resistance of combustion chamber (see Technical data on page 4).

Burner selection:

FUEL	APPROPRIATE BURNER
OIL	Oil burner with fan tested and designated by EN 267 norm.
GAS	Gas burner with fan tested and designated by EN 676 norm.

10.1. BURNER ADJUSTMENT

Burner must be adjusted according to the technical instructions for the oil / gas burner.

10.2. BURNER MOUNTING

Burner mounting is used if the factory made opening on the boiler door is too large for the chosen burner. In that case it is necessary to make an appropriate opening for the passage of the burner tube and to cut the existing mineral wool isolation layer according to the mentioned opening. If it is necessary, make attach holes for the burner.

Figure 4: Burner mounting on the boiler EKO-CUP V3

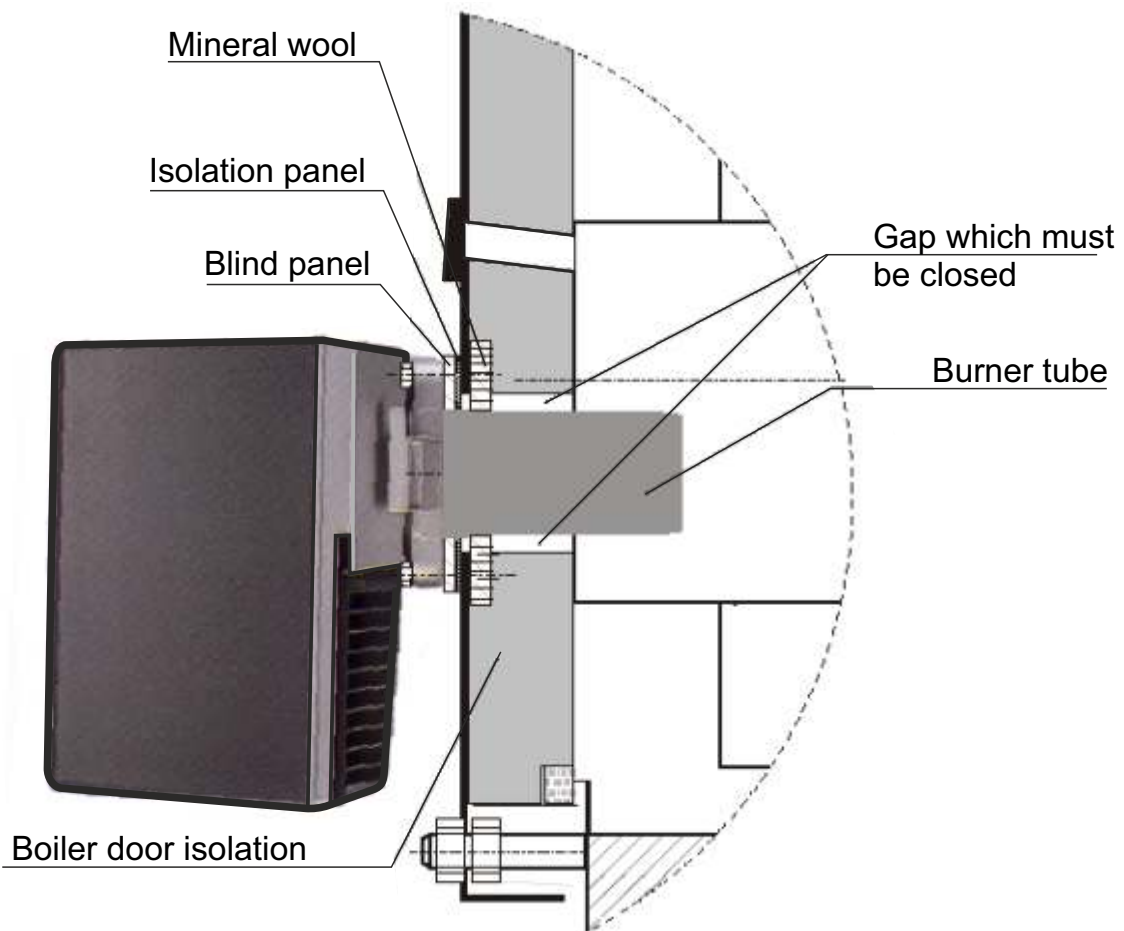

ATTENTION !!

If the factory made opening on the boiler door is too large for the chosen burner, it is necessary to make an appropriate opening for burner tube passage on the blind panel. The existing isolation mineral wool layer have to be cut to be consistent with that opening. For the burner connection use the existing holes or if it is necessary make new attach holes for the burner. If after the boiler montage, the gap between the burner tube and the mineral wool isolation of the boiler door still exist, it is necessary to fill the gap with pieces of the mineral wool and the braid (which is delivered with the boiler) so that the gap becomes closed (Figure 4).

11.0. BOILER CHECK AND STARTUP

The boiler must not be used in flammable and explosive environment.

It must not be used by children or disabled persons (either physically or mentally), as well as by persons without knowledge or experience, unless they are under control or trained by a person responsible for their safety. Protective gloves are obligatory (Figure 5). Check if the boiler and the whole heating system is filled with water and air-vented.

Check if the flue gas tube is properly sealed and if the boiler is connected to the electrical supply. The burner startup must be done by a qualified and authorized service or person.

11.1. INSTALLATION CHECK AFTER STARTUP

After startup please check :

- if there is no water leakage
- if the filling/drainage valve in the system is closed
- if the complete installation is air-vented
- if the boiler water temperature rises
- activate the safety valve and check if it works properly
- that during continuous boiler operation there is no visible chimney condensation

Please repeat the complete check after several days.

11.2. OPERATION AND MAINTENANCE

Boiler must not operate in flammable and explosive environment. It must not be used by children or disabled persons (either physically or mentally), as well as by persons without knowledge or experience, unless they are under control or trained by a responsible person for their safety. Children must be supervised in the vicinity of the product. Protective gloves are obligatory (Figure 5). During boiler-heating system take over, please check the complete heating system together with the service technician. The service technician must inform you about the general heating system and about its supervision. Beyond this you must be informed about the vital parts of the heating systems and their function. After several days of boiler operation please air-vent the heating system once more and fill it with water if necessary. At least once a year (before heating season) it is necessary that authorized service technician check the burner, so the boiler and the heating system operation will be safe and economic. In case of operation disturbances please contact only the **authorized service technician**.

12.0. CLEANING

Protective gloves are obligatory (Figure 5). It is necessary to clean the boiler at least once a year. Before cleaning switch off the main switch on the boiler control panel, thus prevent a possible burner start. Open the boiler door and pull out turbulators, clean boiler tubes and the combustion chamber with the brush. The chimney and the end part of turbulator tubes can be cleaned through the opening on the back of the boiler. After cleaning return turbulators and the lid of the cleaning opening on the back side of the boiler and close the boiler door.

Figure 5: Protective gloves

Protective gloves are obligatory!





EC IZJAVA O SUKLADNOSTI EC DECLARATION OF CONFORMITY

Proizvođač
Manufacturer: **Centrometal d.o.o.**
Naziv i adresa
Name and address: **HR-40306 Macinec, Glavna 12, Croatia**

**Punom odgovornošću izjavljuje, da
We declare under our sole responsibility that**

Proizvod
Product designation: **Toplovodni kotao za loženje ekstra lakim loživim uljem (LU EL) / prirodni plin 2H (G20, 20 i 25 mbar)
Hot-water boiler burning oil (LTO, TOLEX) / natural gas 2H (G20, 20 and 25 mbar)**

Tip / model
Type / model: **EKO-CUP S3 (460 kW, 530 kW, 600 kW)
EKO-CUP V3 (800 kW, 1000 kW, 1250 kW, 1500 kW)**

**EKO-CUP S3, EKO-CUP V3 kotlovi za loženje prirodnim plinom 2H (G20, 20 i 25 mbar) označeni s CE-1015CQ0504:
EKO-CUP S3, EKO-CUP V3 boilers burning natural gas 2H (G20, 20 and 25 mbar) designated with CE-1015CQ0504:**

odgovara zahtjevima sljedećih propisa: / is in conformity with the provisions of the following Directives:

Uredba Komisije / Commission Regulation (EU) 2016/426

Direktiva / Directive 2014/35/EU, LVD

Direktiva / Directive 2014/30/EU, EMC

i također zadovoljava zahtjeve sljedećih standardi: / and also complies with the following standards:

ČSN EN 15502-1+A1:2017; ČSN EN 15502 2 1+A1:2017; ČSN EN 437+A1:2009; ČSN EN 303-1:2018; ČSN EN 303-3:1999;

ČSN EN 14394+A1:2009 (apl. art.); ČSN 06 1008:1997; ČSN EN 60335-1:2012 ed. 3; ČSN EN 60335-2-102:2016 ed.2;

ČSN EN 55014-1:2007 ed.3; ČSN EN 61000-6-3:2007 ed.2; ČSN EN 61000-3-2:2015 ed.4; ČSN EN 61000-3-3:2014 ed. 3;

ČSN EN 61000-6-2:2006 ed 3; ČSN EN 62233:2008

EKO-CUP S3, EKO-CUP V3 kotlovi za loženje ekstra lakim loživim uljem (LU EL) označeni s CE-1015CQ0505:

EKO-CUP S3, EKO-CUP V3 boilers burning oil (LTO, TOLEX) designated with CE-1015CQ0505:

odgovara zahtjevima sljedećih propisa: / is in conformity with the provisions of the following Directives:

Direktiva / Directive 2014/35/EU, LVD

Direktiva / Directive 2014/30/EU, EMC

i također zadovoljava zahtjeve sljedećih standardi: / and also complies with the following standards:

ČSN EN 303-1:2018; ČSN EN 303-2:2018; ČSN EN 14394+A1:2009 (apl. art.); ČSN 06 1008:1997; ČSN EN 60335-1:2012

ed. 3; ČSN EN 60335 2 102:2016 ed.2; ČSN EN 55014-1:2007 ed.3; ČSN EN 61000-6-3:2007 ed.2; ČSN EN 61000 3

2:2015 ed.4; ČSN EN 61000-3-3:2014 ed. 3; ČSN EN 61000-6-2:2006 ed 3; ČSN EN 62233:2008; ČSN EN 267:2012 ed.2

Godina izdavanja CE oznake
Year of affixing of CE marking

2015.

Mjesto i vrijeme izdavanja
Place and date of issue

Macinec, 22.10.2018.

Ime, prezime i potpis ovlaštene osobe
Name, surname and signature of authorized person

Davor Zidarić





Centrometal d.o.o. shall not be responsible for possible incorrect data caused by printing errors or error made in transcription and all figures and diagrams are for explanatory purposes only and relevant adjustment have to be made at the spot. In any case, it reserves the right to modify its products as deemed to be required and useful without any prior notification.

Centrometal d.o.o. Glavna 12, 40306 Macinec, Croatia

central tel: +385 40 372 600, fax: +385 40 372 611
service tel: +385 40 372 622, fax: +385 40 372 621

www.centrometal.hr
e-mail: servis@centrometal.hr

Centrometal
HEATING TECHNIQUE
