

# Centrometal

HEATING TECHNIQUE

Centrometal d.o.o. - Glavna 12, 40306 Macinec, Croatia, tel: +385 40 372 600, fax: +385 40 372 611

ENG

## TECHNICAL INSTRUCTIONS

for installation, use and maintenance  
of the hot water boiler  
and installation of the additional equipment

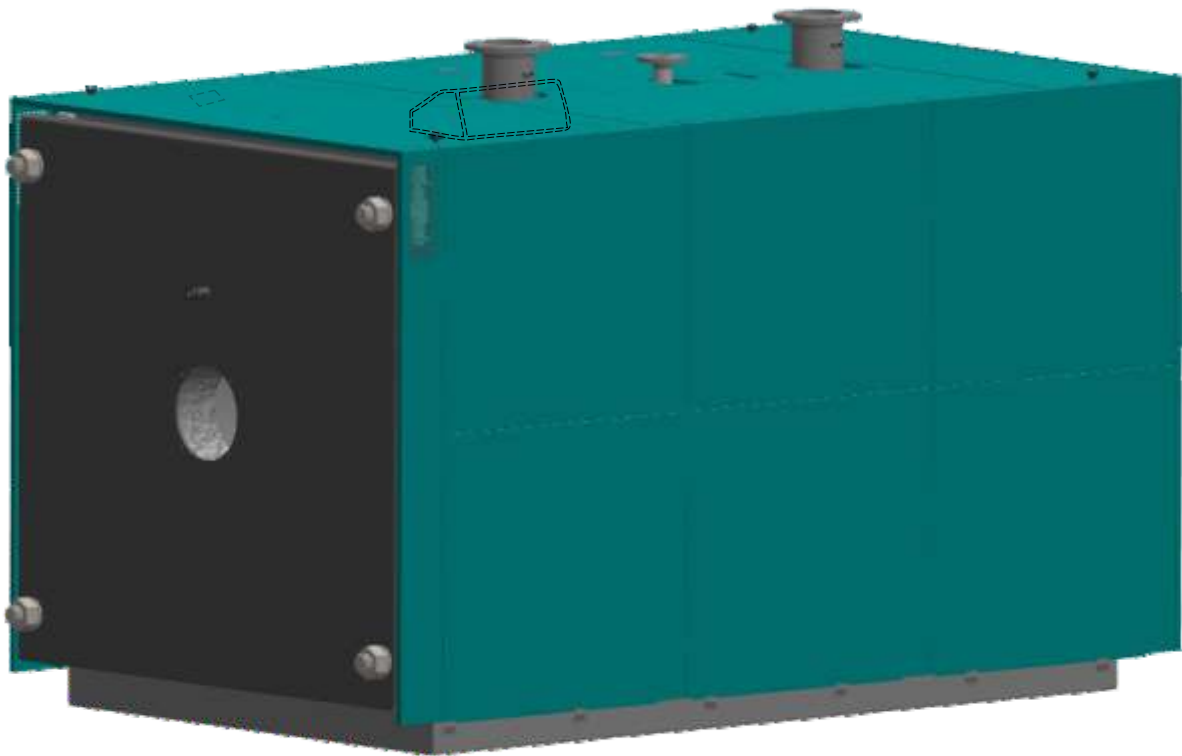

# EKO-CUP SV3 2500



These instructions are an integral part of this product. All rights reserved. Reproduction of content of this document and transfer to third parties is not allowed without written approval from manufacturer. Make sure the instructions are always with the device, even if it is sold/transferred to another owner, so user or authorized person for maintenance or repairs can consult it.



**READ THESE INSTRUCTIONS CAREFULLY BEFORE INSTALLING THE BOILER TO HEATING SYSTEM!**



**Boiler must not be used by children or disabled persons (either physically or mentally), as well as by persons without knowledge or experience, unless they are under control or trained by a person responsible for their safety. Children must be supervised in the vicinity of the product.**



**Boiler must not operate in flammable and explosive environment.**



**Before any work on the boiler, electric energy must be switched off.**



**Please note that the installation, startup and maintenance can only be performed by a qualified heating contractor or service organization. Any work on electrical installations and fuel carrying components must be done by a qualified service technician.**

**EXPLOSIVE DANGER DUE TO FLAMMABLE FUMES!**

**WHAT TO DO WHEN YOU SMELL SMOKE?**



- Shut off main gas /oil supply!
- Open windows and doors!
- No open fire! Do not smoke! Do not use a lighter!
- Avoid generating sparks! Do not use an electrical switch, telephone, electrical socket or bell!
- Notify homeowner, but do not use a door bell or phone!
- Leave the building!
- Immediately notify the gas or oil supplier from a remote location!
- If necessary, inform the police or fire department.
- Immediately leave the building, when you hear or see the gas leak!

**Insufficient amount of fresh air for combustion in the boiler room can lead to dangerous conditions.**

**Make sure that the openings for combustion air supply are not reduced or closed.**



**Keep the boiler room door closed.**

**Protect the boiler room and avoid rodents and birds from entering and blocking the air openings.**

**If the above mentined issues are not solved, the boiler cannot be put into operation.**

## 1.0. TECHNICAL DATA

TYPE	EKO-CUP SV3 2500	2500
Nominal heat output	(kW)	2100
Heat output range	(kW)	630-2100
Required chimney draught	(mbar)	0,1
Water amount in boiler	(l)	3000
Exhaust gas temperature at nominal heat output (Qn)	(°C)	165°C
Exhaust gas temperature at minimum heat output (0,3 x Qn)	(°C)	95°C
Emissions of nitrogen oxides Nox OIL/GAS	(mg/kWh)	180,4/104
Resistance of the combustion chamber at 80% power output	(mbar)	6,7
Resistance of the combustion chamber at 100% power output	(mbar)	10,4
Fuel type		oil/gas
Maximum heat input OIL/GAS	(kW)	2264,15/2289,57
Exit flue gas mass flow at 100% power output OIL/GAS	(kg/s)	0,966/0,981
Exit flue gas mass flow at 30% power output OIL/GAS	(kg/s)	0,297/0,302
CO2 content at 100% power output OIL/GAS	(%)	12,61/9,71
Combustion chamber dimensions	(mm)	Φ 935x2800
Combustion chamber volume	(l)	1922
Combustion chamber type		overpressure
Gas volume of the boiler	(m <sup>3</sup> )	3,28
Supply voltage	(V)	230/400
Frequency	(Hz)	50
Current type		~
Total mass - (boiler with casing and accessories)	(kg)	5194
Max. operating overpressure	(bar)	6
Test pressure	(bar)	9
Max. operating temperature	(°C)	100
Flue gas outlet pipe diameter	(mm)	Φ 450
Useful effic. at 30% of rated heat out. and low temp. regime OIL/GAS (η1)(%)		93,75/93,24
Useful eff. at rated heat output and high temp. regime OIL/GAS (η4) (%)		92,75/91,72
Standby heat loss (Pstby)	(kW)	-
Auxiliary electricity consumption (Weishaupt WM-GL30-2-ZM-T)	at full load (elmax) (kW)	5.997
	at part load (elmin) (kW)	3.685
	in standby mode (PSB) (kW)	0.006
Flame operation		direct flame operation
Burner type (Weishaupt WM-GL30-2-ZM-T)		multi stage

### DESCRIPTION:

values given in the table are test report values issued by SZU s.p., Brno, Czech Republic.

### GAS/OIL:

burner Weishaupt WM-GL30-2-ZM-T

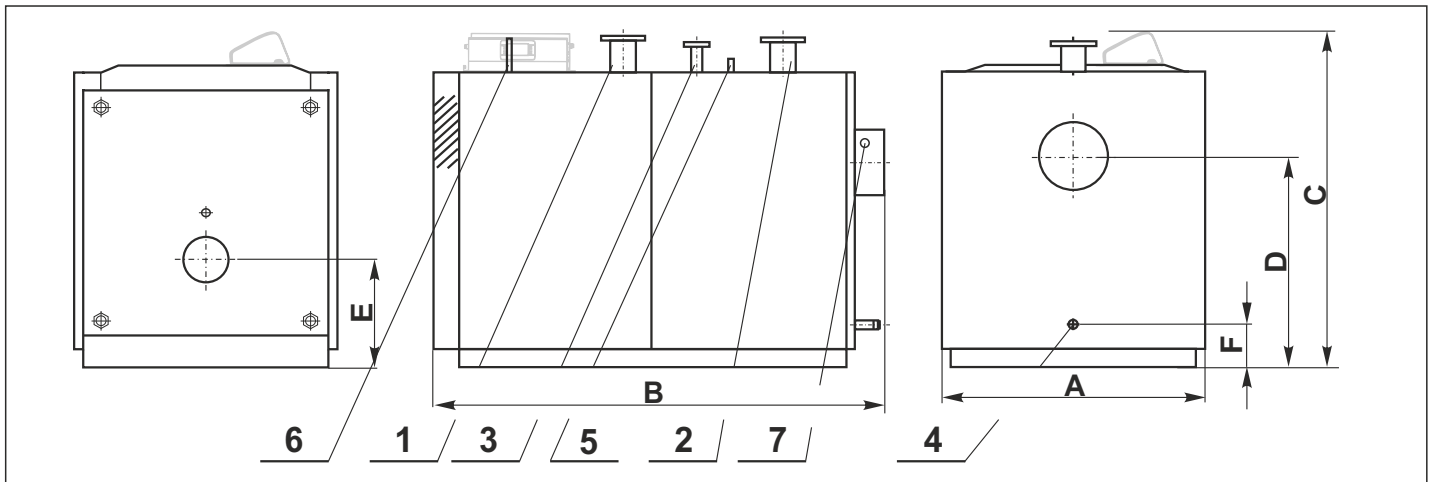

BOILER DIMENSIONS		EKO-CUP SV3 2500
A Boiler width	(mm)	1932
B Boiler length	(mm)	3485
C Boiler height	(mm)	2145
D Boiler flue exhaust	(mm)	1580
E Burner opening	(mm)	1035
F Filling / drainage	(mm)	135
1 Boiler return	DN (PN 16)	150
2 Main flow	DN (PN 16)	150
3 Safety line	DN (PN 16)	50
4 Filling / drainage	R"	6/4
5 Sensors / gauges	R"	1/2
6 Min / Max pressure limit switch	R"	1/2
7 Position for probe - exhaust gases emissions	R"	1/2

**Boiler resistance on water side**

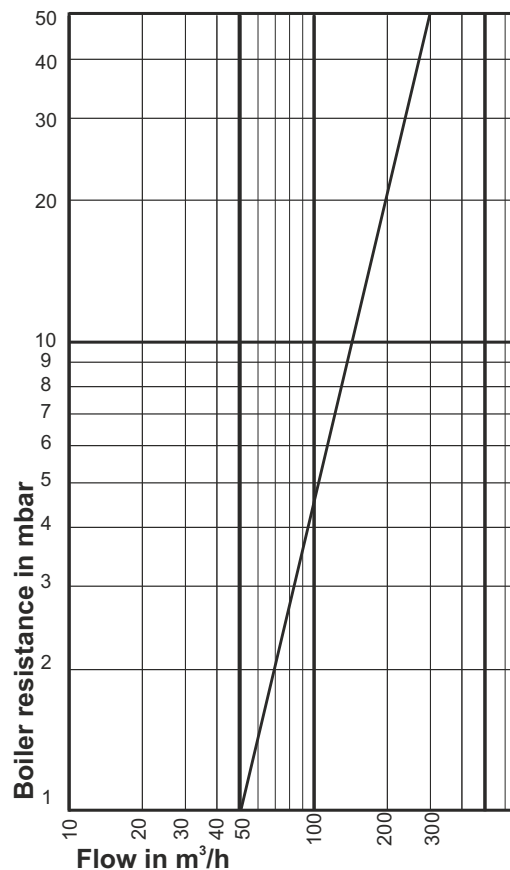

## 2.0. BOILER EKO-CUP SV3 2500 COMPONENT PARTS

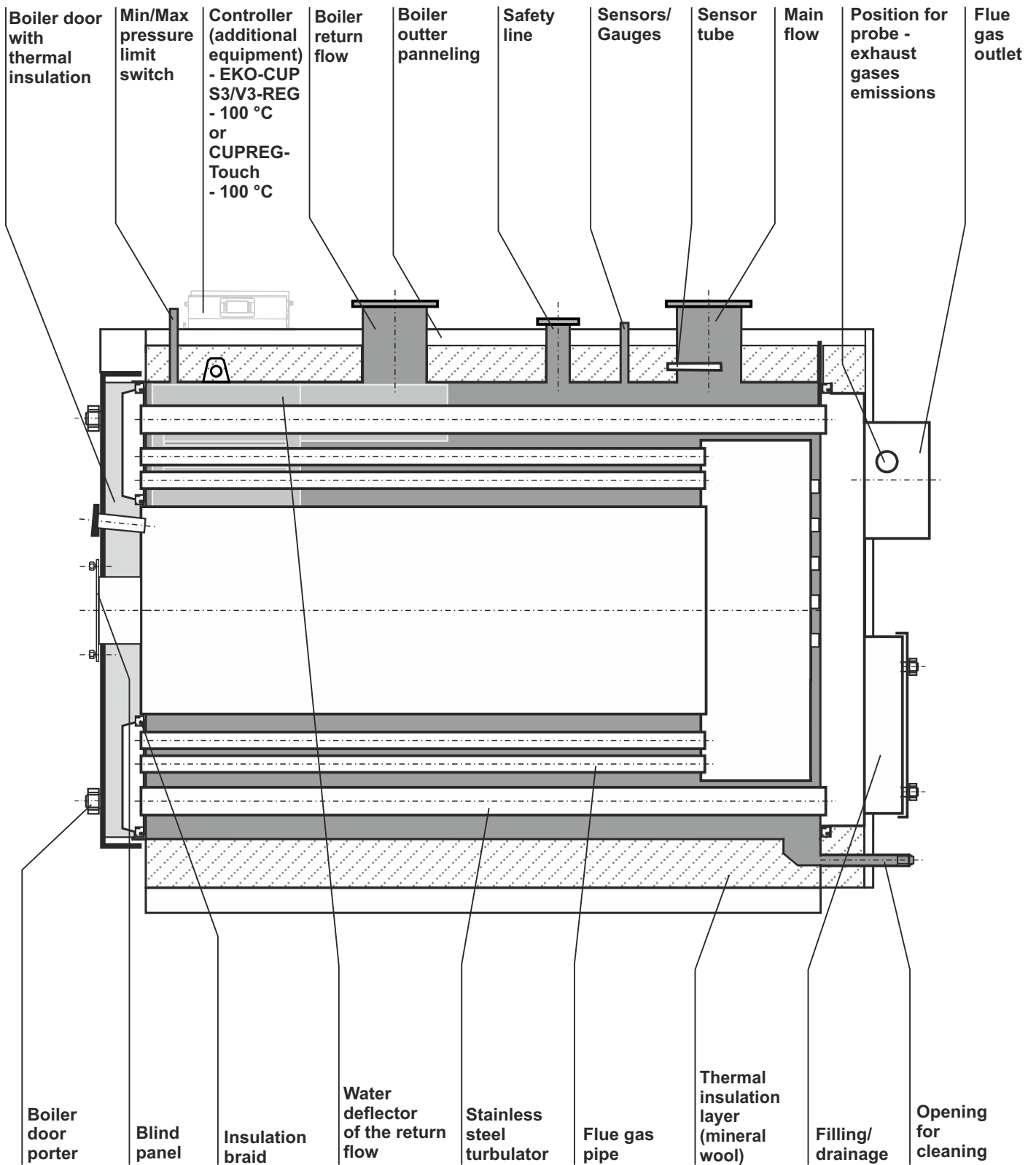

### **3.0. IN GENERAL**

The new boiler **EKO-CUP SV3 2500** for central heating is intended for firing with fuel oil extra light (FOEL) and gas. The boiler has a modern construction and design regarding to the designed capacity. It is made out of controlled high quality materials, welded with the most modern technology. The boiler EKO-CUP SV3 2500 is approved and tested in accordance with EN standards and fulfills all special requirements for connection to the central heating installation.

### **3.1. BOILER DESCRIPTION**

The boiler **EKO-CUP SV3 2500** is a triple pass flue gas flow system steel hot water boiler. Flue gases flow from the combustion chamber into the tube of second pass and then into the tube of third pass, where turbulators are placed. Turbulators enable better transmission of the thermal energy to the boiler water and also enable the fine flue gas outlet temperature control.

### **4.0. BOILER DELIVERY**

The boiler **EKO-CUP SV3 2500** is delivered with outer boiler panelling made of plastificated sheet metal and thermal mineral wool insulation. Afterwards it is possible to build in one or two additional control units for the heating control of one or more boiler and heating circuits.

#### **OBLIGATORY ACCESSORIES (ORDERED ADDITIONALLY):**

- Basic boiler controller EKO-CUP S3/V3 - REG - 100 °C

or

- Basic boiler controller CUPREG-Touch - 100 °C

### **5.0. BOILER MOUNTING**

It is recommended to mount the boiler **EKO-CUP SV3 2500** into the boiler room, which has to be built in accordance with the boiler heating power, normal operation conditions, undisturbed serving and easily accessible boiler, burner and boiler equipment. The boiler must be placed on the 5 to 10 cm high concrete slab above the ground. Slab edges must be protected by an iron made frame (50x50x5). The boiler must be positioned in order to enable supervision during boiler operation, cleaning and maintenance. Due to easier transport of the boiler into the boiler room, mounting of the thermal insulation has to be done after the boiler is properly placed in the boiler room as shown on the Figure 1.

**Figure 1: The boiler outer panelling assembly EKO-CUP SV3 2500**

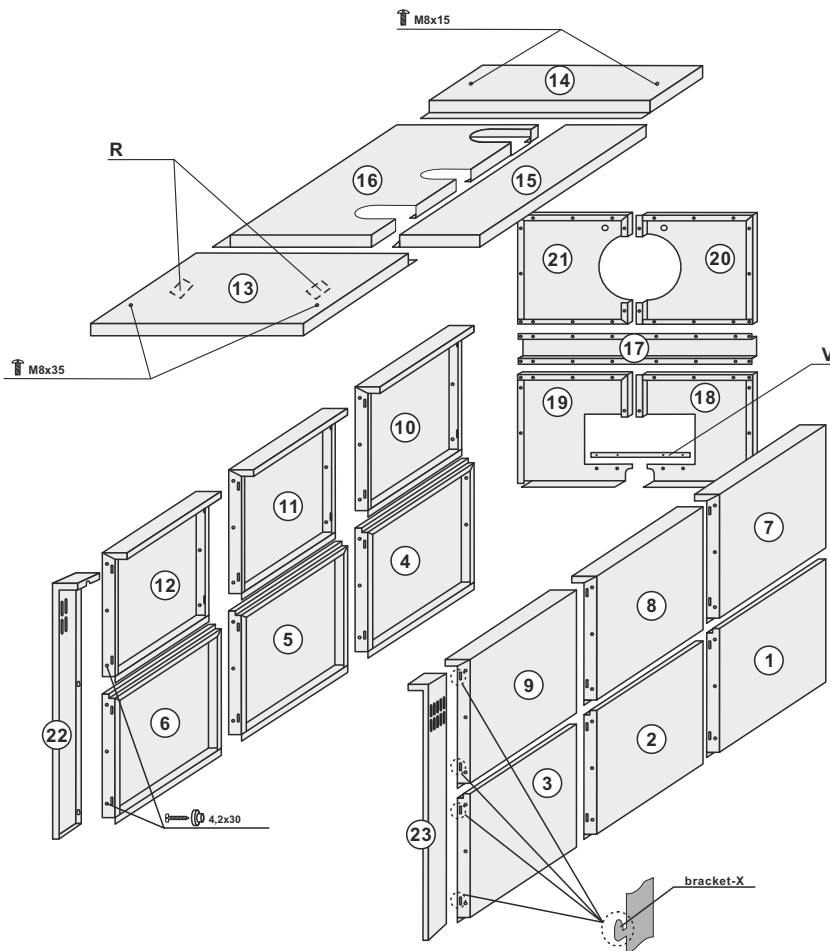

**PROCES OF PANNELING ASSEMBLY ON THE BOILER:**

1. Put side panels onto bracket-X in the order shown on the figure – panels (1) to (12) (panels (1) to (6) are the same and panels (7) to (12) are the same).
2. Attach the top front panel (13) with two M8x35 screws to the boiler and do the same with the top rear panel (14).
3. Screw the two 3,9x13 screws slightly (not to the bottom) on the left and right side of the top front plate (13).
- 4.\* Remove the perforated part (R) on the upper front panel (13), depending on the desired side of the controller.
5. Depending on the installation position of the boiler controller (possible installation: left or right side of the boiler), open one of the perforated holes (R) on the upper panel (13) and pass the boiler rcontroller sensors through it and all of them except the flue gas sensor (if the boiler controller have it) put it in the sleeve for the boiler sensors (see figure 2), and put the flue gas sensor (if the boiler controller have it) through the intended hole on the back side of the boiler casing (see figure 2) and put it in the sleeve for the sensor on the boiler chimney (see figure 2). Place the regulation on the 3.9x9.5 screws and tighten the screws completely (to the bottom).
6. Put the top right panel (15) on the boiler.
7. Put the top left panel (16) on the boiler.
8. Attach the connection panel and back panels (18 to 21) to the top rear panel and the side panels (1, 4, 7 and 10) with 4,2x30 screws. Attach the connection panel (V) to the panels (18 and 19).
9. Side panels (3, 6, 9 and 12) attach to the door protection brackets (22 and 23) with 4,2x30 screws and then attach door protections to those brackets.

\* Controller (EKO-CUP S3/V3 - REG - 100°C or CUPREG-Touch - 100°C - additional equipment) it can be placed on the left or right side of the boiler.



## Figure 2: Controller instalation

- controller can be placed on the left or right side of the boiler.

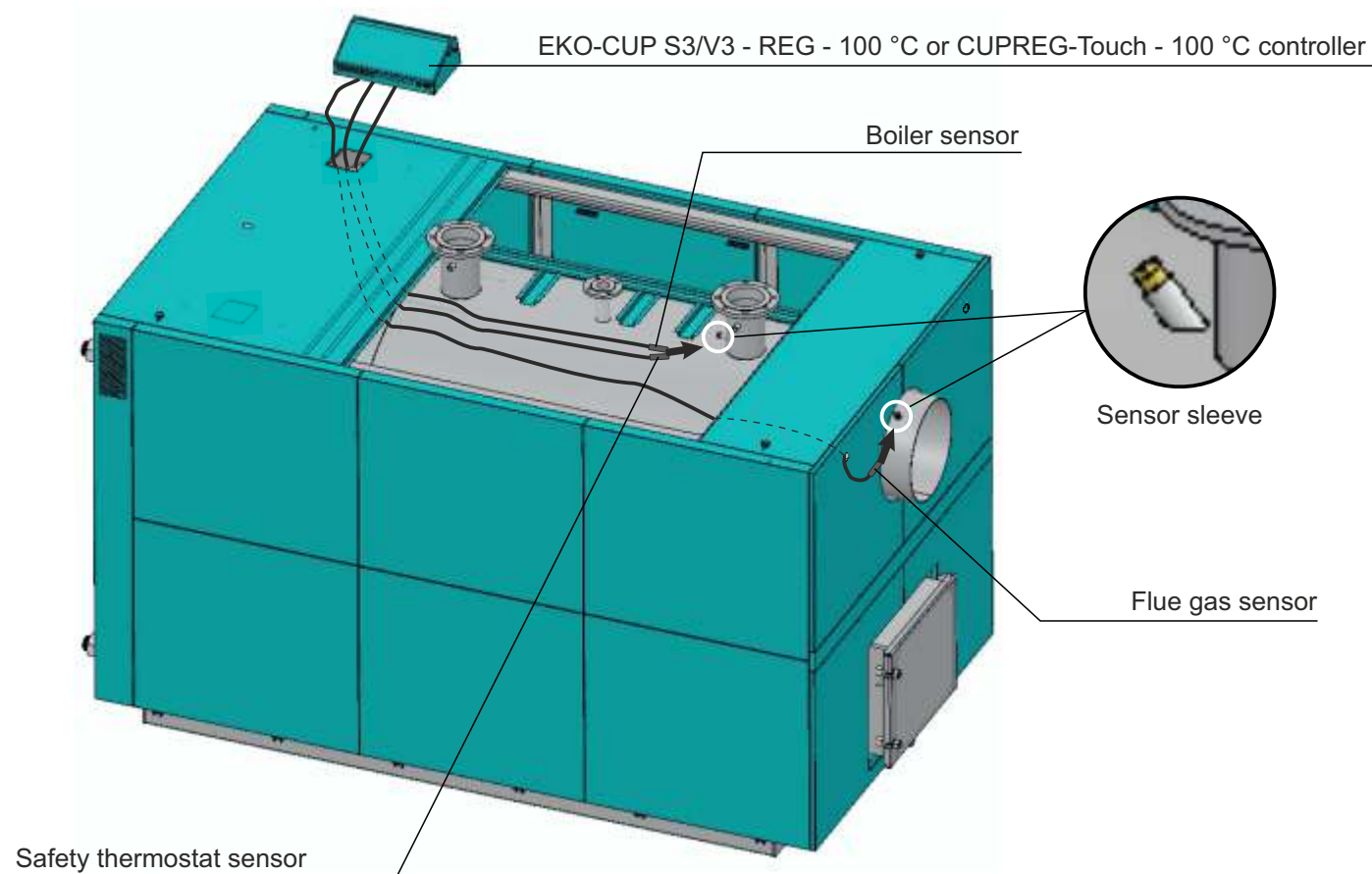

### Flue gas sensor installation procedure

- fasten the controller with metal screws 3,9 x 9,5 (2 pcs.)



- first unscrew the plug from the socket (1)
- put on the sensor sleeve (2)
- put on the flue gas sensor (3)

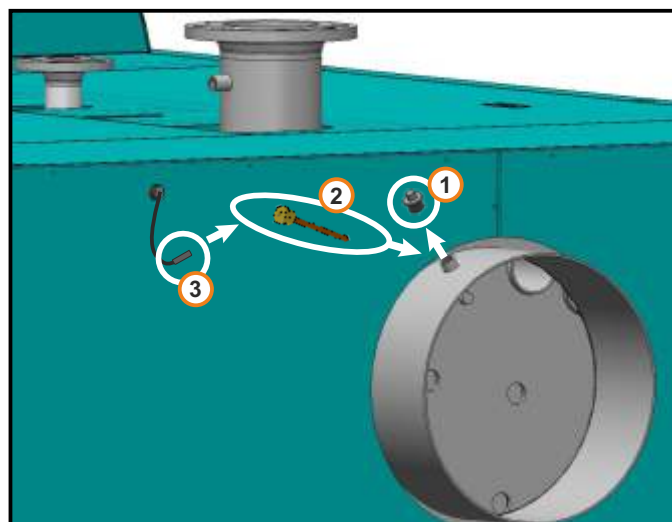
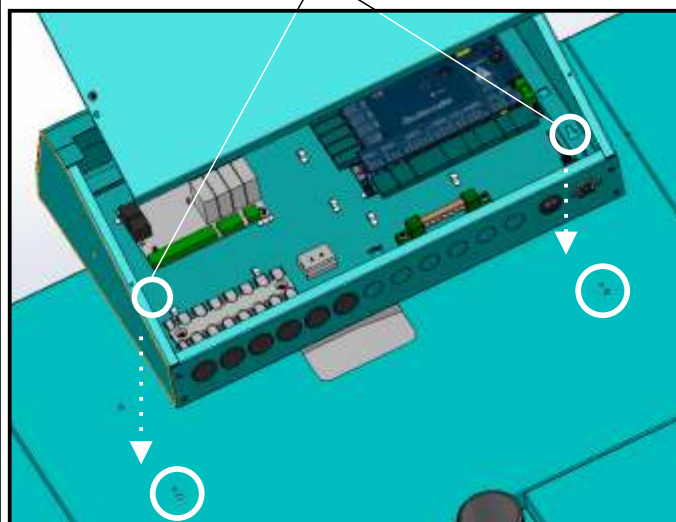

## 6.0. CHIMNEY

Correctly calculated and performed chimney is a precondition for a safe boiler operation and economic heating results. The chimney must be well thermal insulated, gas-impermeable and smooth. On the lower part of the chimney a cleaning door must be installed. A walled chimney must be three-layered with a middle mineral wool insulation layer. The thickness of the insulation should be at least 30 mm thick if the chimney is mounted inside the building and 50 mm thick if is mounted outside the building walls. The inner diameter of the chimney depends upon the actual chimney height and the boiler heating power. The flue gas temperature on the chimney exit has to be at least 30°C higher than the condensation temperature of combustion flue gases.

To ensure safe, reliable, efficient and long-lasting boiler operation, the chimney must be calculated in accordance with the norm EN 13384-1 (software such as KESAAadin or similar).

## 7.0 CONNECTION TO THE CHIMNEY

The flue gas tube between the boiler and the chimney has to be mounted under an inclination between 30 to 45° (Figure 3). To prevent the entering of condensing fluid from the chimney into the boiler it is necessary and important to mount the flue gas tube 10 mm deeper into the chimney. It is highly recommended to insulate the flue gas tube, especially if is longer than 1m. For easier flue gas tube cleaning the tube must have an opening (Figure 4). Connections of the flue gas tube on the boiler and chimney must be properly made and sealed. For easier chimney cleaning we recommend the distance at least 1m between the boiler and the chimney or wall.

Figure 3: Possible way to connect the EKO-CUP SV3 2500 boiler to the chimney

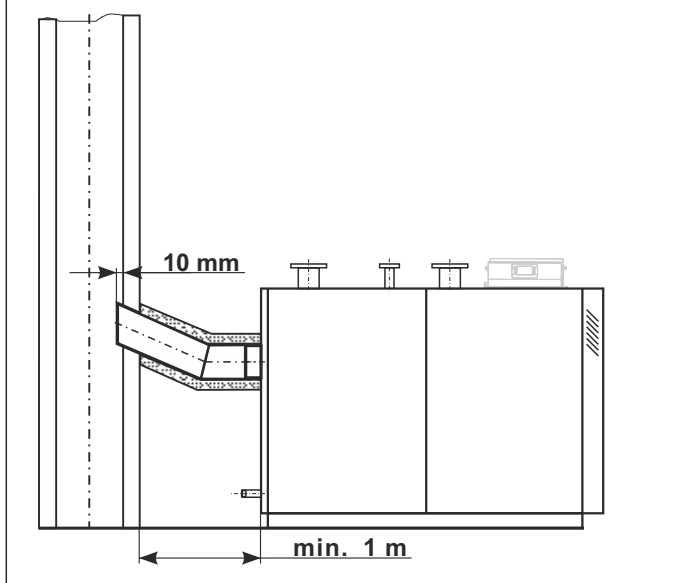
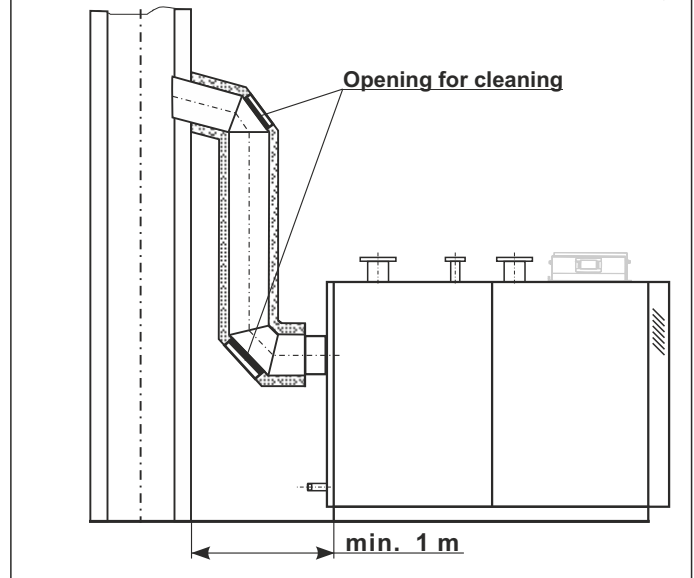

Figure 4: Possible way to connect the EKO-CUP SV3 2500 boiler to the chimney



## 8.0. FRESH AIR OPENING

Every boiler room must have a correctly calculated **opening for fresh air inlet** regarding to the boiler heating power. The diameter of the fresh air opening must be calculated:

$$A = 6.02 \times Q$$

A - surface of the opening in cm<sup>2</sup>

Q - boiler heating power in kW

The opening must be protected by a net or grid.

## **9.0. CONNECTION TO THE INSTALLATION**

All installation works must be done in accordance with valid national and European standards. Before boiler connection to the heating installation it is necessary to clean all tubes in the system from dirt layers. These actions prevent boiler overheating, noise in the heating system, disturbances on the pump and mixing valve. In a closed heating system, it is obligatory to install certificated safety valve with opening overpressure set on 6 bar. Safety and expansion lines must not have any shut-off elements. Drainage of heating water flowing through the safety valve is conducted direct to the sewerage. During the water filling into the heating system it is necessary to open the mixing valve if it is mounted and to air-vent the boiler and the heating system. Boiler connection to the central heating installation must be performed as it is shown on Scheme 1. and in accordance with the norm EN 12828:2012+A1:2014.

As it is shown on Scheme 1., the boiler must be connected to the heating system over hydraulic crossover and the boiler return flow protection must be performed with 3-way mixing valve with motor actuator, that will keep temperature above 60°C. Depending on configuration or controller, this motor actuator may have its own controller or it can be controlled by a boiler controller.

Scheme 1: Hydraulic scheme

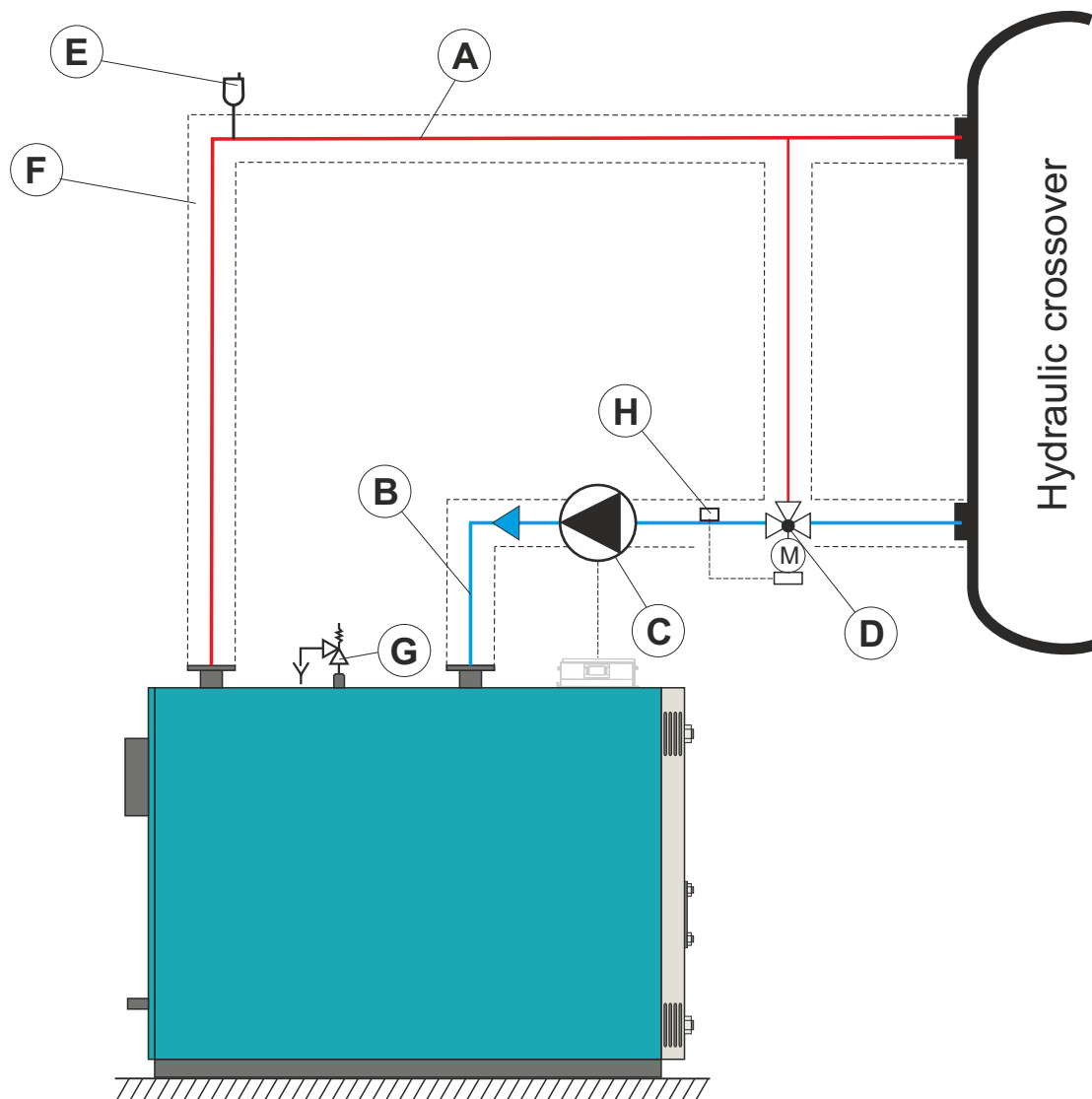

**LEGEND:**

- A** - Boiler main flow
- B** - Boiler return flow
- C** - Circulation pump
- D** - 3-way mixing valve (with sensor + controller)
- E** - Automatic air vent point
- F** - Thermal insulation
- G** - Safety valve 6 bar (only at closed heating circuit)
- H** - Temperature sensor of 3-way mixing valve with motor actuator



**Hydraulic scheme must be performed as shown on this scheme. Other parts of installation, which are not shown on this scheme must be performed according to the norm EN 12828:2012+A1:2014.**

**9.1. WATER QUALITY**

To prevent excessive limescale build-up of calcium carbonate on the boiler heating surfaces, its concentration must be below the permitted maximum values mentioned in the following table:

Boiler	Total alkaline earths mol/m <sup>3</sup>	Total hardness °dH
EKO-CUP SV3 2500	< 0.02	< 0.11

## 10.0. BASIC BOILER CONTROLLER (ADDITIONAL EQUIPMENT)

### 10.1. BASIC BOILER CONTROLLER - EKO-CUP S3/V3 - REG - 100 °C - DESCRIPTION, INSTALLATION AND CONNECTION TO THE EL. INSTALLATION

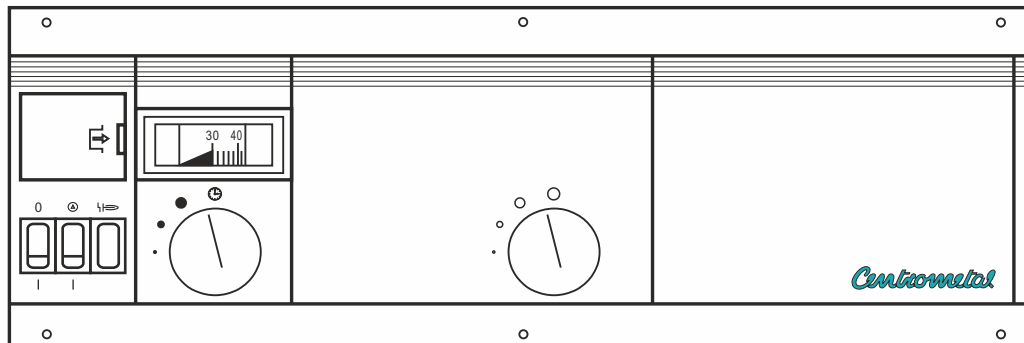

- see the technical instructions supplied with the boiler controller - EKO-CUP S3/V3 - REG - 100 °C

### 10.2. BASIC BOILER CONTROLLER - CUPREG-Touch - 100 °C - DESCRIPTION, INSTALLATION AND CONNECTION TO THE EL. INSTALLATION

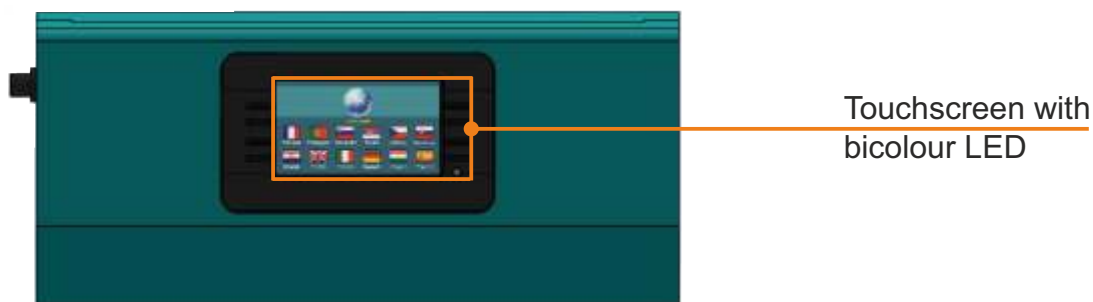

- see the technical instructions supplied with the boiler controller - CUPREG-Touch - 100 °C

## 11.0. BURNER SELECTION

The burner must be selected in accordance with nominal boiler heating power and combustion chamber resistance at nominal power (see Technical data on the page 4.).

**Burner selection:**

FUEL	APPROPRIATE BURNER
OIL	Oil burner with fan tested and designated by EN 267 norm.
GAS	Gas burner with fan tested and designated by EN 676 norm.

### 11.1. BURNER ADJUSTMENT

The burner must be adjusted in accordance with technical instructions for the oil / gas burner.

## 11.2. BURNER MOUNTING

The opening on the boiler door is factory made and it is used for burner mounting. The gap between the burner tube and the insulation or the boiler door must be filled with pieces of the mineral wool or braid (which is delivered with the boiler).

DIMENSIONS (mm) - WM-GL30/2 ZM-T

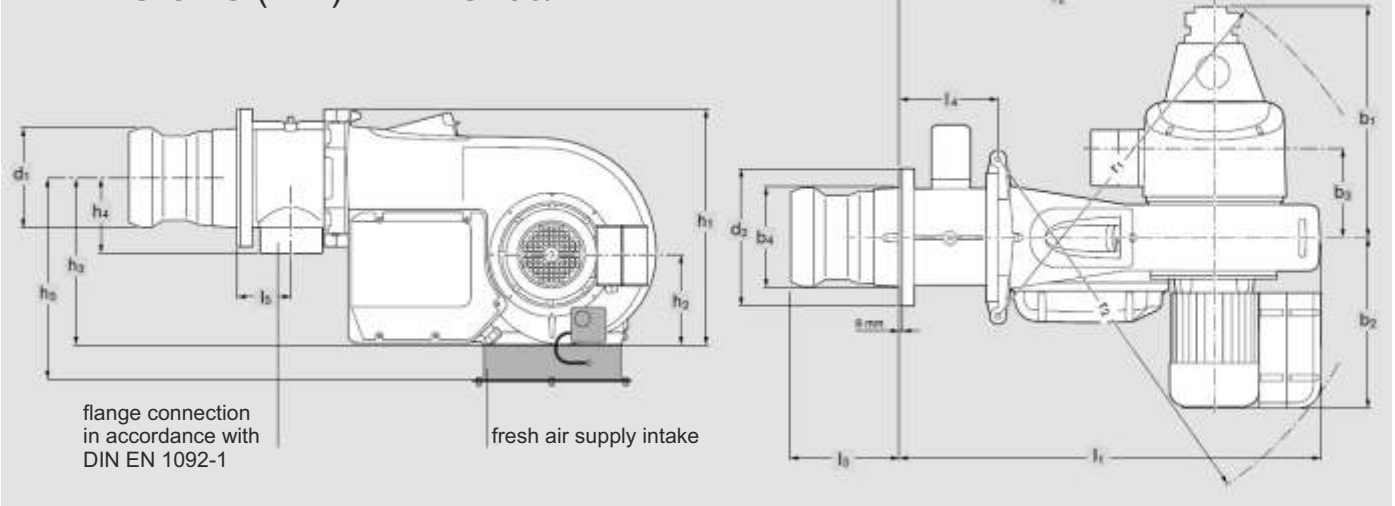

l1	l2	l3	l4	l5	b1	b2	b3	b4	h1	h2	h3	h4	h5
1146	827	349 – 374	248	128	610	507	261	301	695	256	505	212	621

Figure 5: Burner mounting on the boiler EKO-CUP SV3 2500

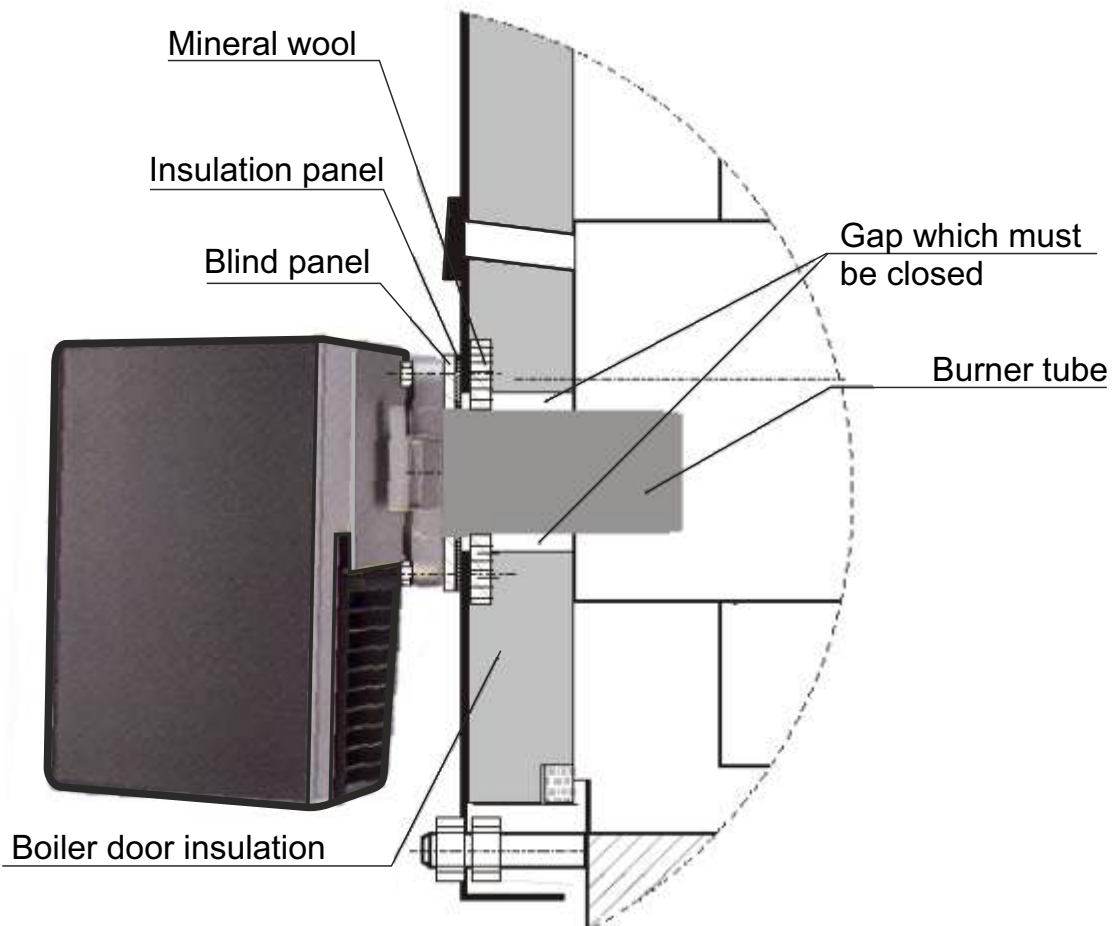

## **12.0. BOILER STARTUP**

Before startup please check if:

- the flue gas tube is properly sealed and the boiler is connected to the power supply
- there is no water leakage
- the filling/drainage valve in the system is closed
- the complete installation is air-vented
- the safety valve works properly (activate the safety valve and check if it works properly)
- the probes for control, indication and safety are installed and positioned in accordance with item "INSTALLATION AND POSITIONING OF CONTROL, INDICATION AND SAFETY PROBES"
- the burner is installed and positioned in accordance with item "BURNER MOUNTING" and technical instructions, which are given with the burner

Startup must be done by a qualified and authorized service technician for boilers and burners.

The burner has to be set in accordance with technical instructions, which are given with the boiler.

The burner has to be set on (OIL) 2264,15 kW / (GAS) 2289,57 kW of heat input for nominal heat output of 2100 kW.

## 13.0. BOILER USE

### **READ THESE INSTRUCTIONS CAREFULLY BEFORE INSTALLING THE BOILER TO HEATING SYSTEM!**

- Boiler must not be used by children or disabled persons (either physically or mentally), as well as by persons without knowledge or experience, unless they are under control or trained by a person responsible for their safety. Children must be supervised in the vicinity of the product.
- The boiler must not operate in flammable and explosive environment.
- Before any work on the boiler, electric energy must be switched off.
- Any work on electrical and fuel supply components must be done by a qualified service technician.

### **- EXPLOSIVE DANGER DUE TO FLAMMABLE FUMES!**

#### **WHAT TO DO WHEN YOU SMELL SMOKE?**

- Shut off main gas /oil supply!
- Open windows and doors!
- Do not use open fire! Do not smoke! Do not use a lighter!
- Avoid generating sparks! Do not use an electrical switch, telephone, electrical socket or bell!
- Notify homeowner, but do not use a door bell or telephone!
- Leave the building!
- Immediately notify the gas or oil supplier from a remote location!
- If necessary, inform the police and fire department.
- Immediately leave the building, when you hear or see a gas leak!



- Insufficient supply of combustion air in the boiler room can lead to dangerous conditions. Make sure that the combustion air supply openings are not reduced or closed. Keep the boiler room door closed. Protect the boiler room from entering rodents and birds because they can block air openings. If above mentioned conditions are not met, the boiler cannot be put into operation.

- The boiler may be used only by a person appointed by the owner of the boiler and trained by authorized person for the safe use, maintenance and cleaning of the boiler.

- Before boiler use, check if the whole installation is in accordance with the provided general information by the contractor regarding to the heating system operation, position and function of important components in the system. Air-vent the heating system and fill it with water if is necessary.



**14.0. CLEANING AND MAINTENANCE**



- Before opening the boiler door the boiler must be switched off and cooled.
- Before any work on the boiler, power supply must be switched off.
- Protective gloves are obligatory.
- Before any work on the boiler shut off main gas /oil supply!

**Figure 6: Protective gloves**

**Protective gloves are obligatory!**



**CLEANING AND MAINTENANCE SCHEDULE**

ITEM	INTERVAL	DESCRIPTION
Clean the boiler.	Min. once per year (before heating season)	Before cleaning the boiler switch off the main switch on the boiler control panel. This action prevent a possible burner start. Open the boiler door, pull out turbulators and clean boiler tubes and the combustion chamber with the brush. The flue gas chamber and turbulator tube endings can be cleaned through the opening at the back of the boiler. After cleaning return turbulators and the lid of the cleaning opening and close the boiler door.
Burner check by an authorized service technician.	Min. once a year (before heating season)	An authorized service technician has to check the burner (and set new burner settings if necessary).
Heating system check.	Before boiler use	Check if the whole installation is in accordance with provided general information by the contractor regarding to the heating system operation, position and function of important components in the system. Air-vent the heating system and fill it with water if is necessary.







Company assumes no responsibility for possible inaccuracies in this book originated typographical errors or rewriting, all the pictures and diagrams are principal and it is necessary to adjust each actual situation on the field, in any case the company reserves the right to enter their own products such modifications as considered necessary.

**Centrometal d.o.o. Glavna 12, 40306 Macinec, Croatia**

central tel: +385 40 372 600, fax: +385 40 372 611  
service tel: +385 40 372 622, fax: +385 40 372 621

**www.centrometal.hr**  
**e-mail: servis@centrometal.hr**