

Centrometal

HEATING TECHNIQUE

Centrometal d.o.o. - Glavna 12, 40306 Macinec, Croatia, tel: 040 372 600, fax: 040 372 611

ENG

TECHNICAL INSTRUCTIONS

CE

for assembling the basic parts of the boiler,
for installation and control of electrical components
and sensors of boiler

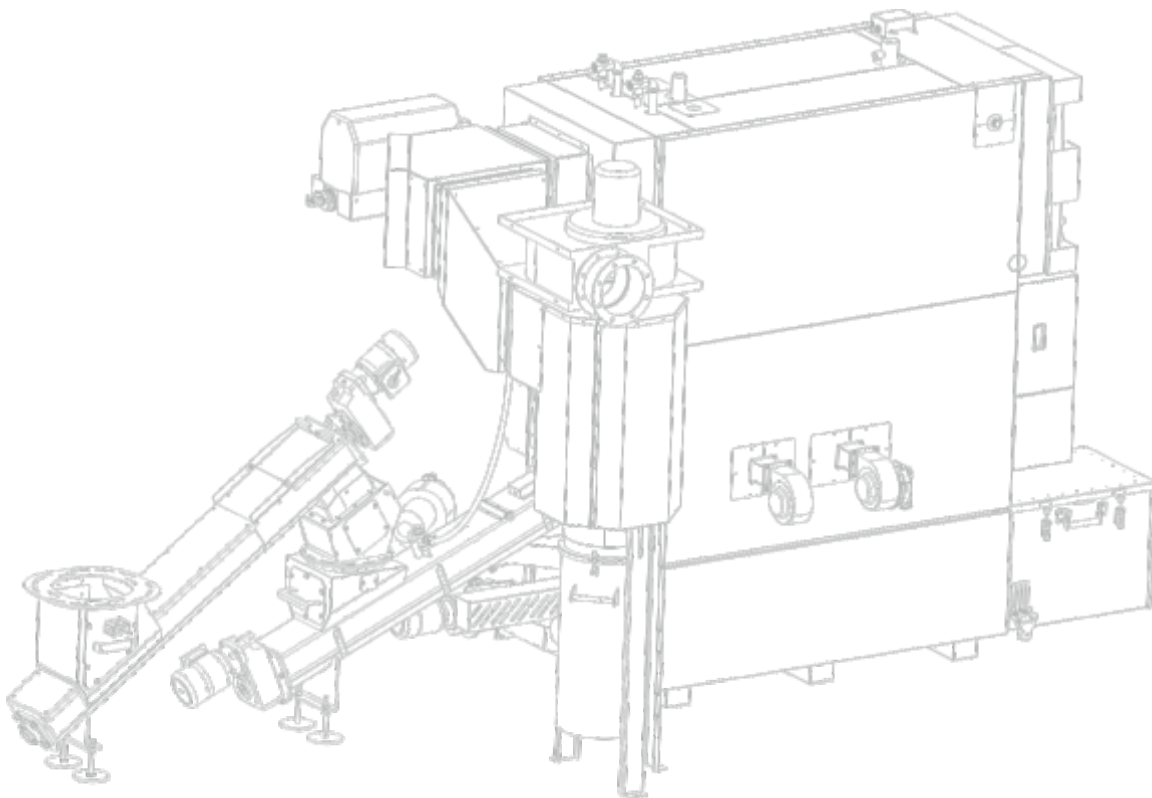

EKO-CKS Multi Plus 170-580



Before any work on the boiler, electric energy must be switched off.
All electrical works must be performed by a certified professional in accordance with valid national and European standards.
A device for switching of all power supply poles must be installed in electrical installation in accordance with the national regulations on electrical installations.

1.0. BOILER ASSEMBLY

1.1. PARTS FOR MOUNTING

1 Secondary air fan G2E120-CR21-01



Boiler	Pcs.
EKO-CKS Multi Plus 170 - 250	2
EKO-CKS Multi Plus 340	2
EKO-CKS Multi Plus 450	2
EKO-CKS Multi Plus 580	2

2 Secondary air fan G2E120-CR21-01 with motor device and lid



Boiler	Pcs.
EKO-CKS Multi Plus 170 - 250	2
EKO-CKS Multi Plus 340	0
EKO-CKS Multi Plus 450	4
EKO-CKS Multi Plus 580	6

3 Motor device with lid U/HC142



Boiler	Pcs.
EKO-CKS Multi Plus 170 - 250	2
EKO-CKS Multi Plus 340	4
EKO-CKS Multi Plus 450 - 580	2

4 Primary air fan 1 U/HC142 0,18kW (EKO-CKS Multi Plus 170,250,340)



Boiler	Pcs.
EKO-CKS Multi Plus 170 - 250	1
EKO-CKS Multi Plus 340	1

5 Primary air fan 1 U/HC152 0,25kW (EKO-CKS Multi Plus 450,580)



Boiler	Pcs.
EKO-CKS Multi Plus 450	1
EKO-CKS Multi Plus 580	1

6 Movable grate motor 0,090kW

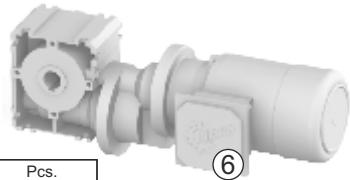

Boiler	Pcs.
EKO-CKS Multi Plus 170 - 250	1
EKO-CKS Multi Plus 340	1
EKO-CKS Multi Plus 450 - 580	1

7 Ash cleaner motor



Boiler	Pcs.
EKO-CKS Multi Plus 170 - 250	1
EKO-CKS Multi Plus 340	1
EKO-CKS Multi Plus 450 - 580	1

8 Connection tube with lid (smaller)

Lid must be always placed on side where is mounted fan / lid with motor device

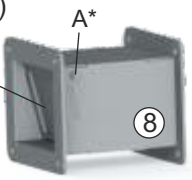

Boiler	Pcs.
EKO-CKS Multi Plus 170 - 250	4
EKO-CKS Multi Plus 340	2
EKO-CKS Multi Plus 450	6
EKO-CKS Multi Plus 580	8

9 Connection tube with lid (bigger)

Lid must be always placed on side where is mounted fan / lid with motor device

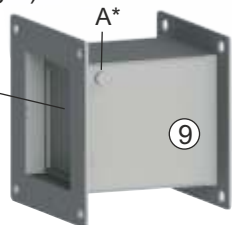

Boiler	Pcs.
EKO-CKS Multi Plus 170 - 250	2
EKO-CKS Multi Plus 340	4
EKO-CKS Multi Plus 450 - 580	2

* Lid shaft. Must be positioned with upper side nearer fan / lid with motor device (depend about mounting position).

1.2. FANS AND AIR REGULATOR MOUNTING

1. Mounting Fan G2E120-CR21-01

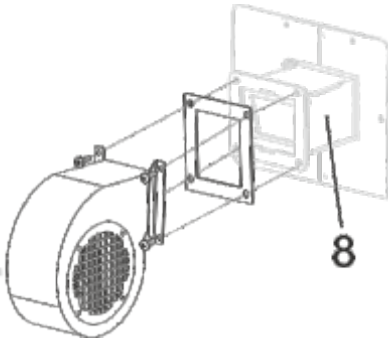

2. Mounting Fan G2E120-CR21-01 with lid operated by motor device

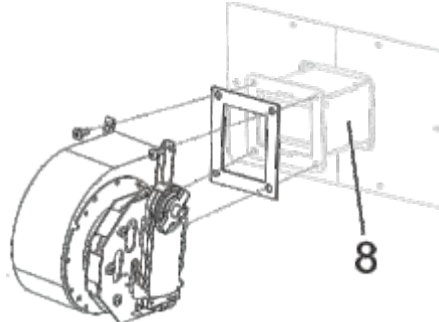

3. Mounting Air regulator to the boiler (only EKO-CKS Multi Plus 340)

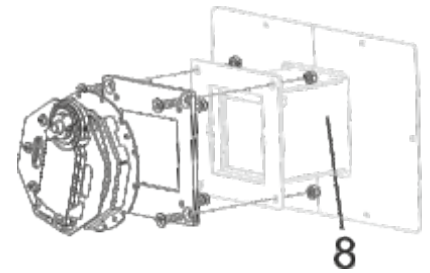

EKO-CKS Multi Plus 170, 250

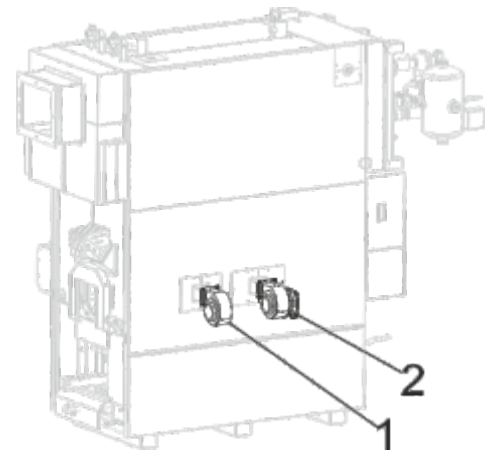
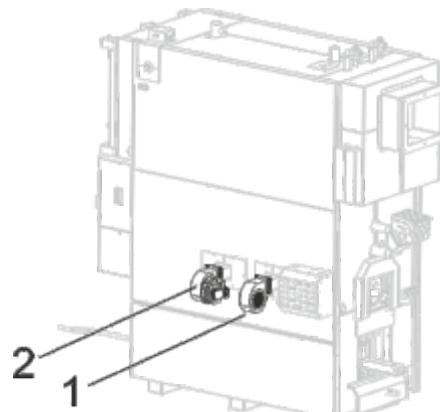

EKO-CKS Multi Plus 340

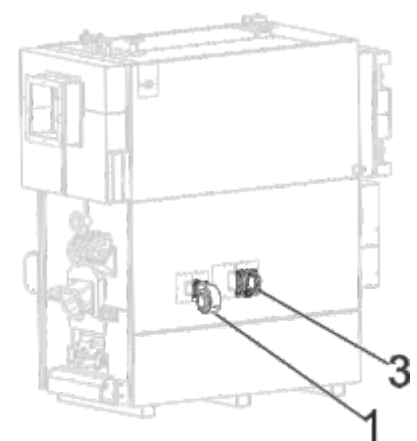
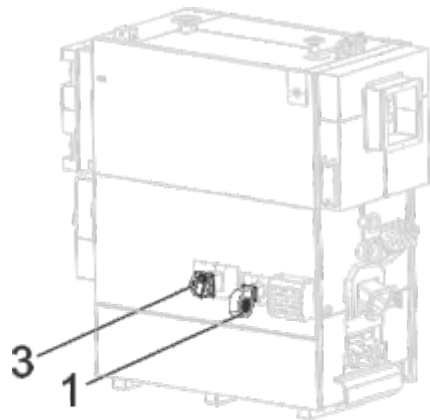

EKO-CKS Multi Plus 450

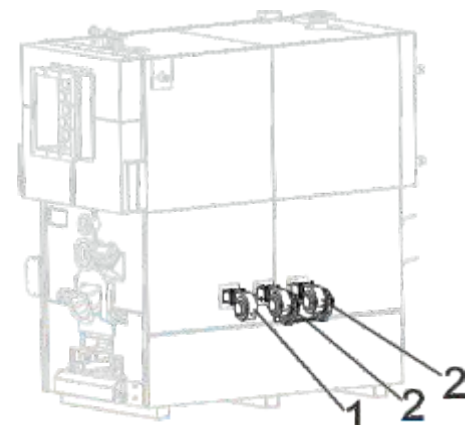
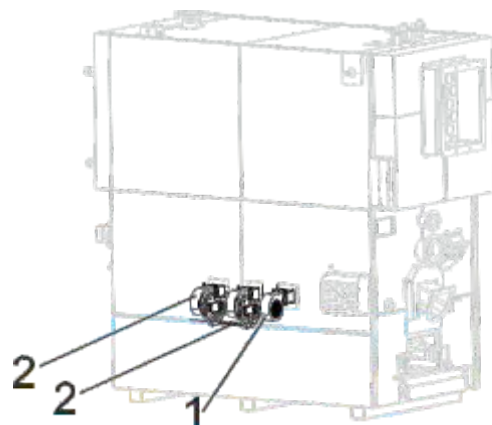

EKO-CKS Multi Plus 580

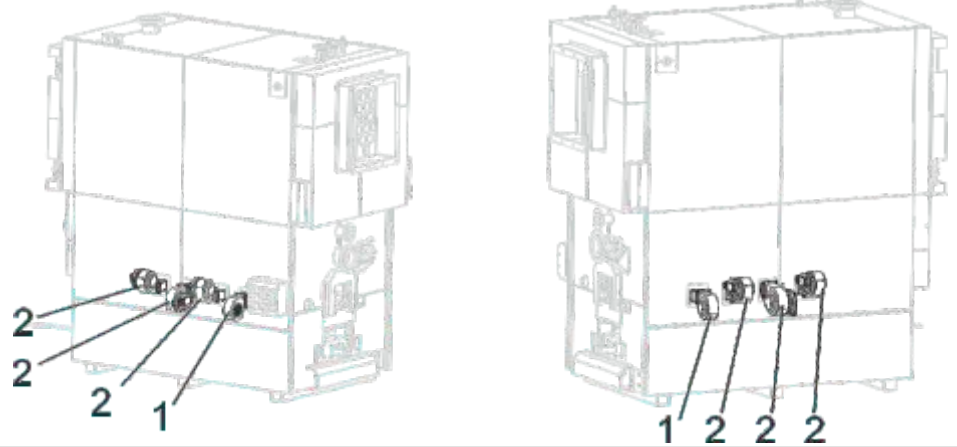

1.3. ASSEMBLY OF PRIMARY AIR CHANNEL (LOWER)

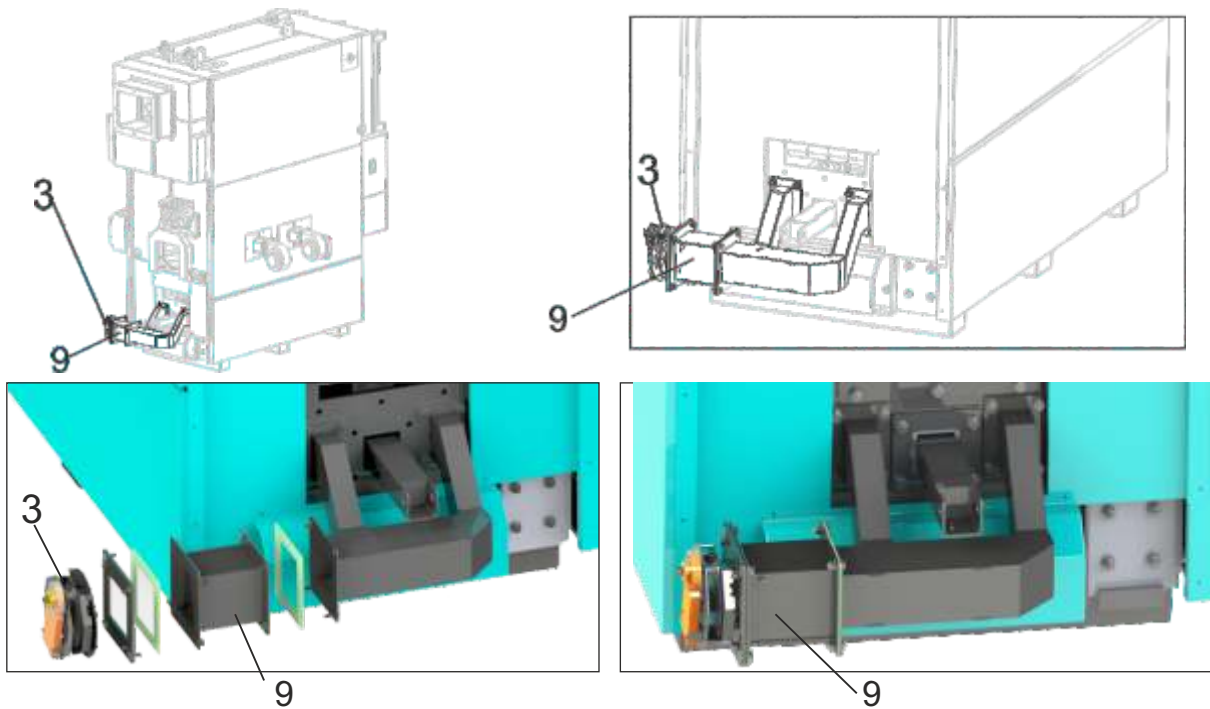

1.4. ASSEMBLING MOTOR DRIVE OF THE MOVABLE GRATE

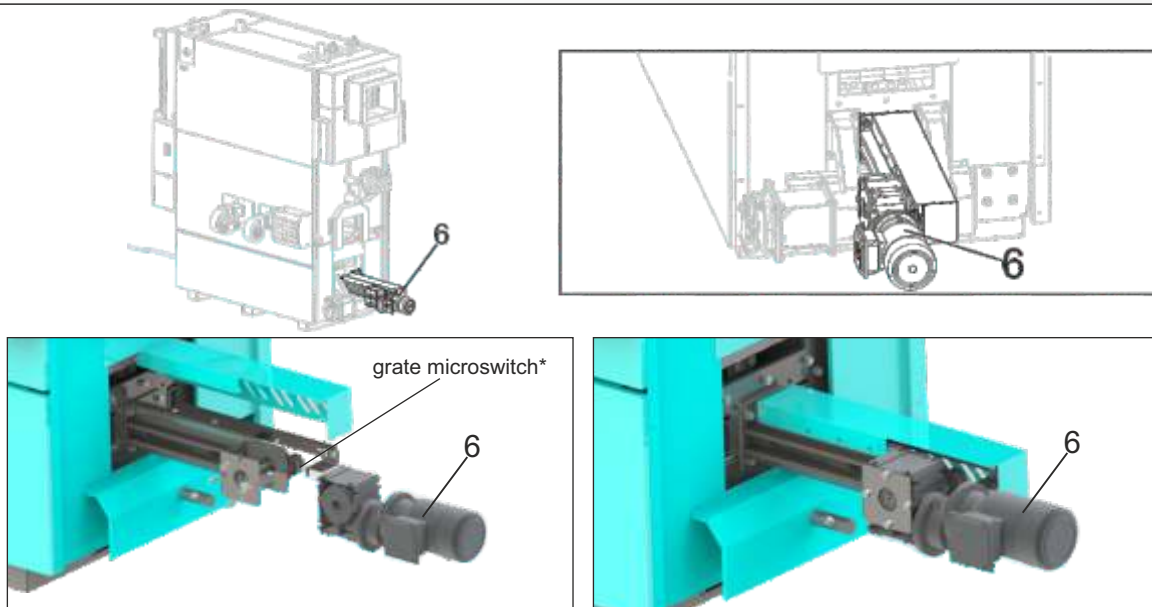

* it must be installed in such a way that the lever in the extreme right position presses the microswitch.

- the lever pressed the grate microswitch (fig. A)
- screen appearance in the manual test when the grate microswitch is pressed (fig. B)
- screen appearance in the manual test when the grate microswitch is not pressed (fig. C)

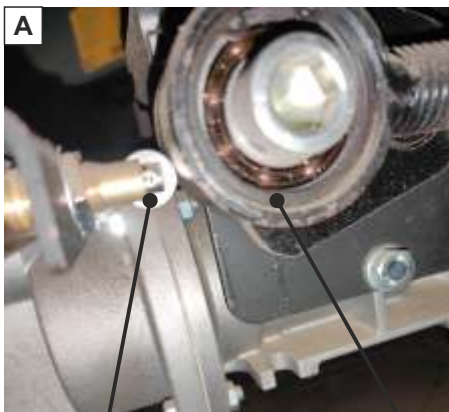

Grate microswitch*

Lever

* it must be installed in such a way that the lever in the extreme right position presses the microswitch.

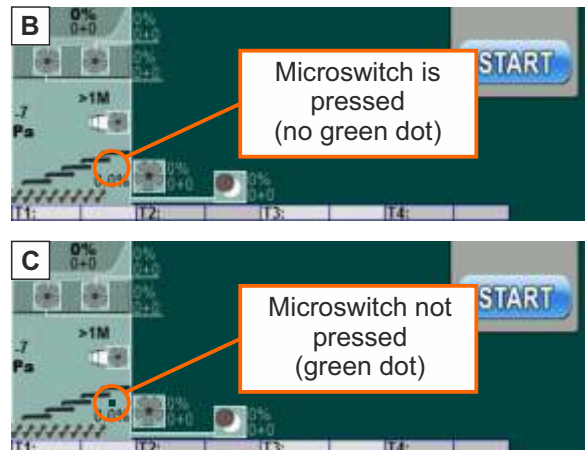

1.5. ASSEMBLING MOTOR DEVICE OF ASH CLEANER

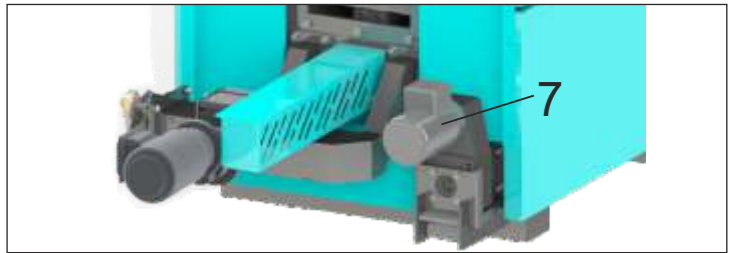
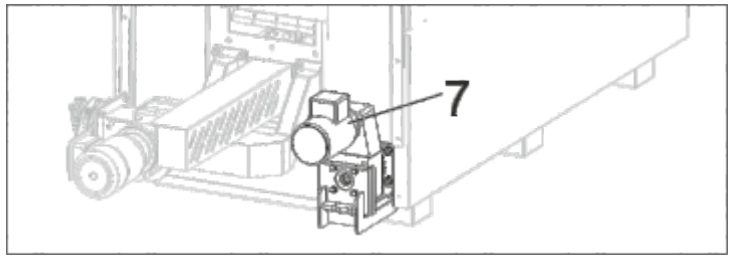
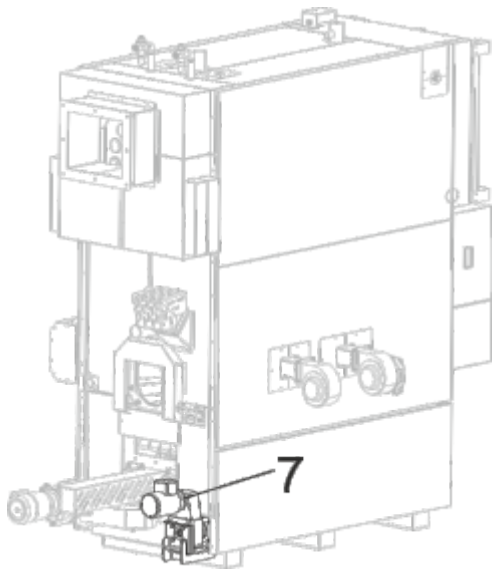

1.6. ASSEMBLY OF PRIMARY AIR CHANNEL WITH FAN (UPPER)

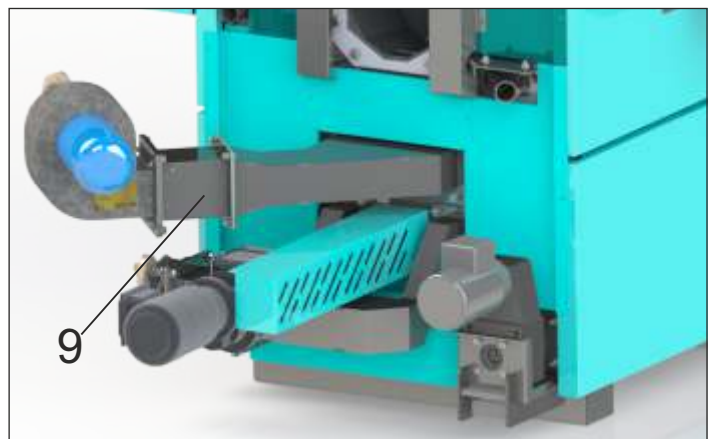
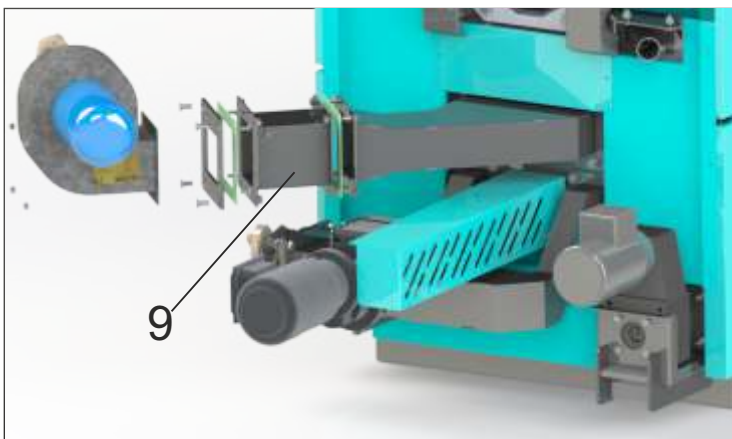
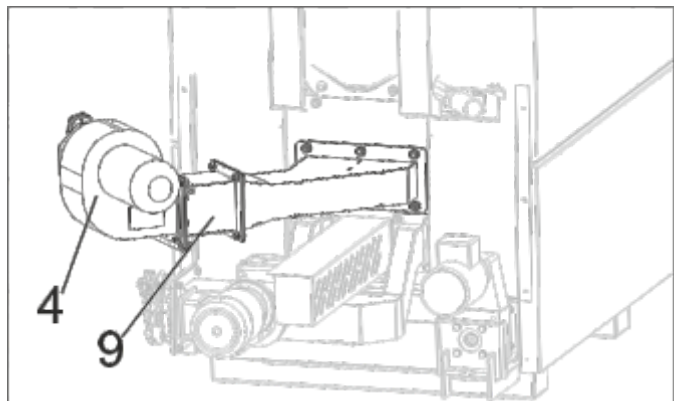
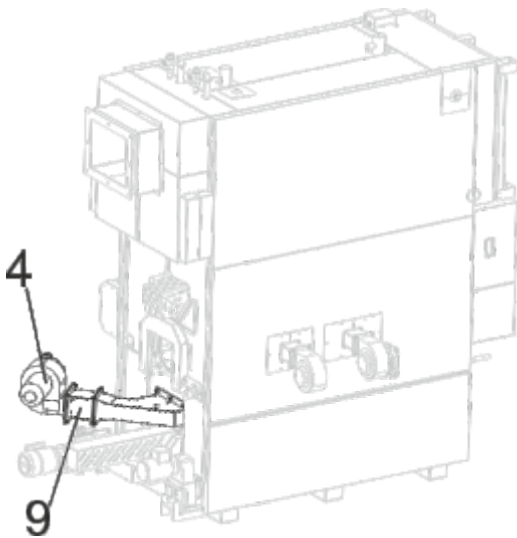

1.7. INSTALLATION OF ELECTRIC IGNITER WITH FAN AND PROTECTION

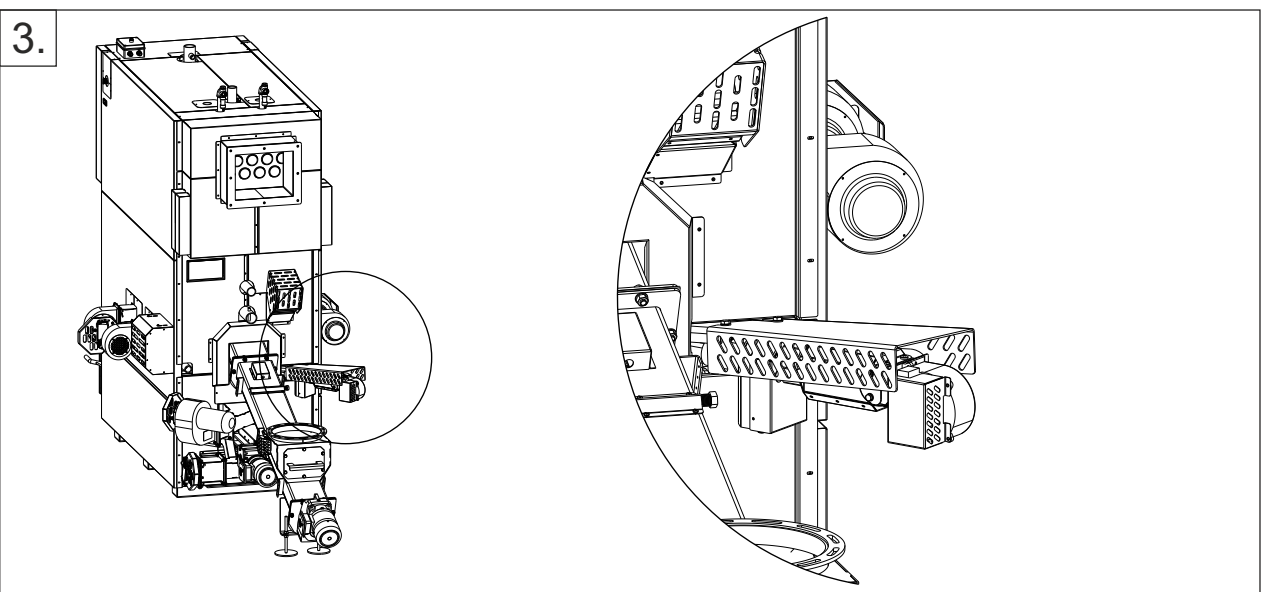
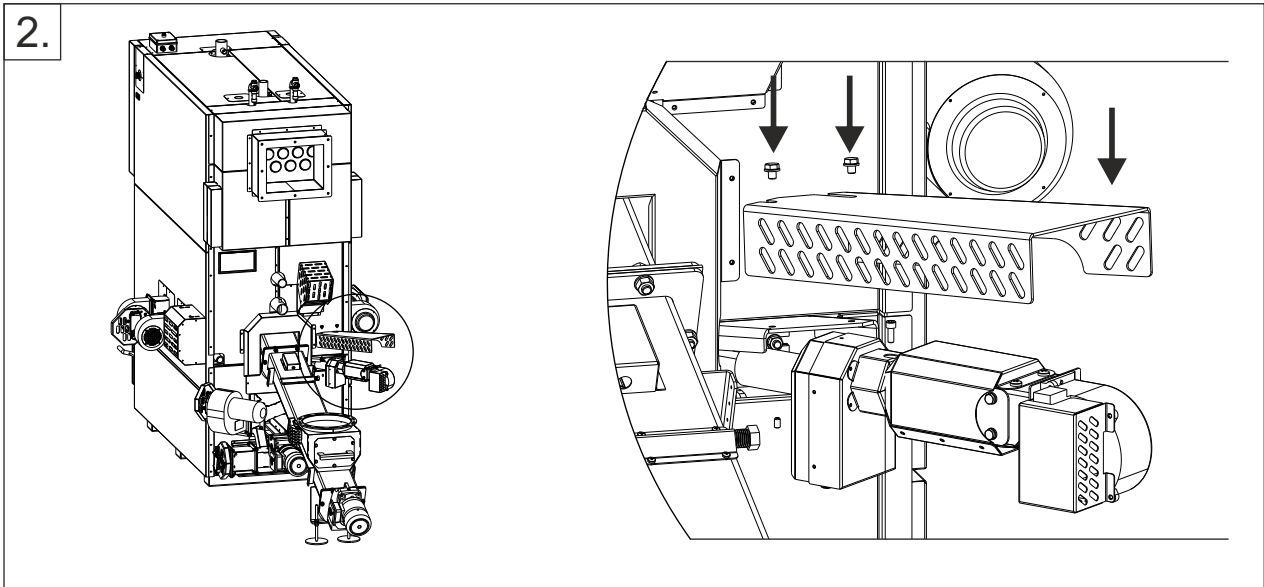
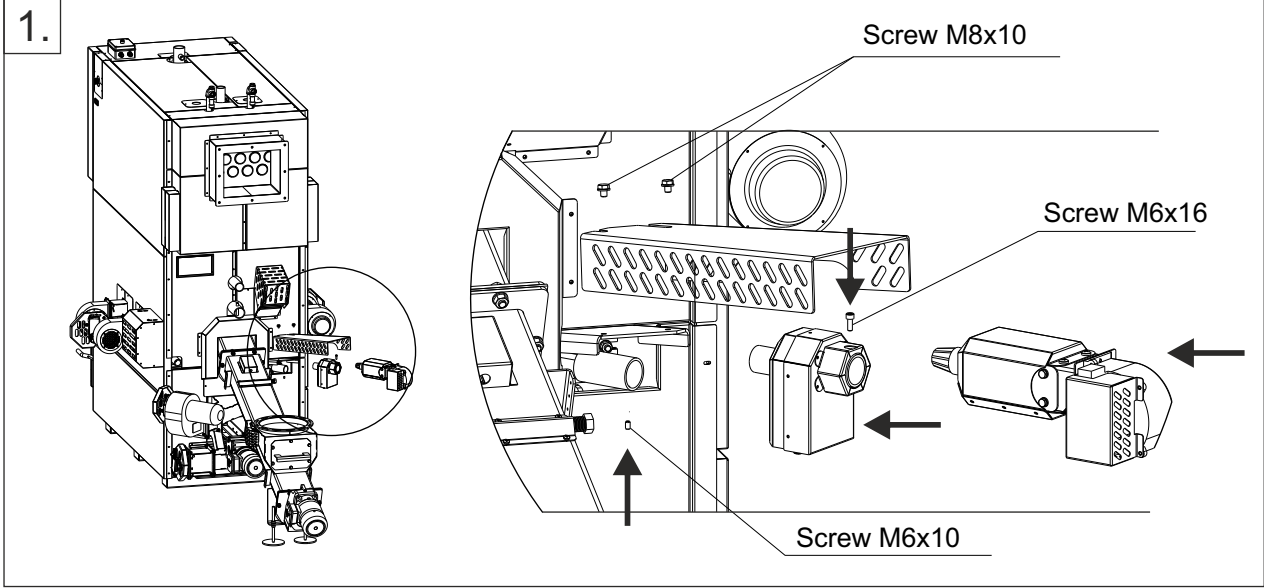

1.8. ASSEMBLY OF SAFETY DOOR PROTECTION

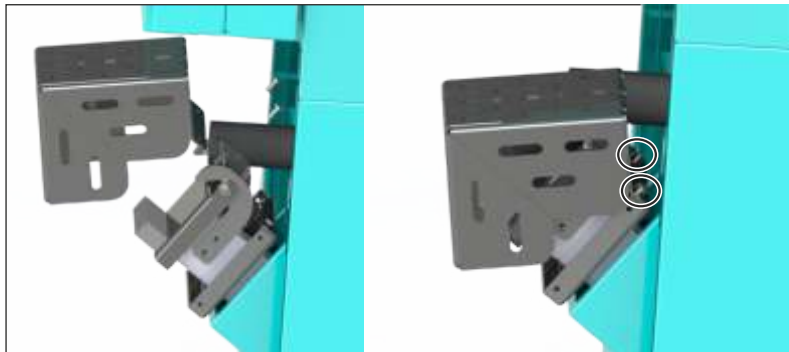
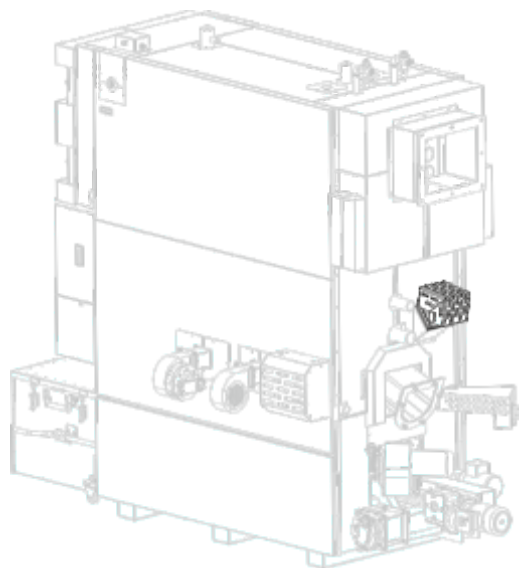

1.9. ASSEMBLY OF SCREW CONVEYOR 1

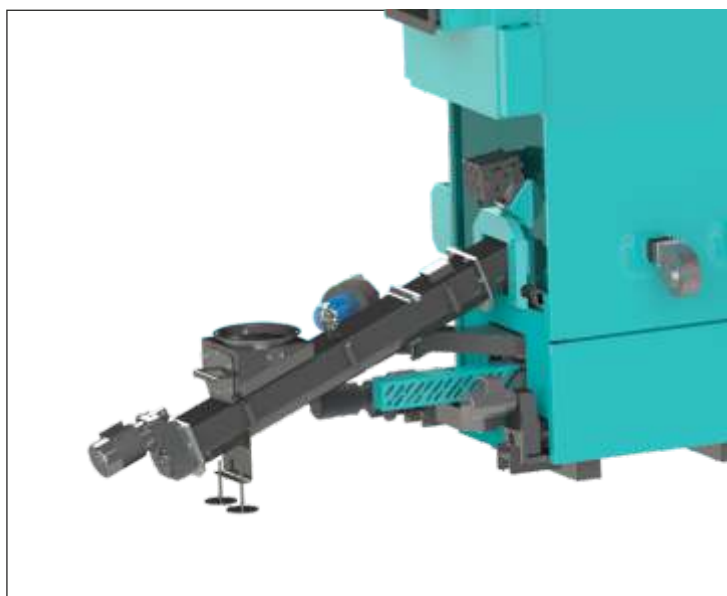
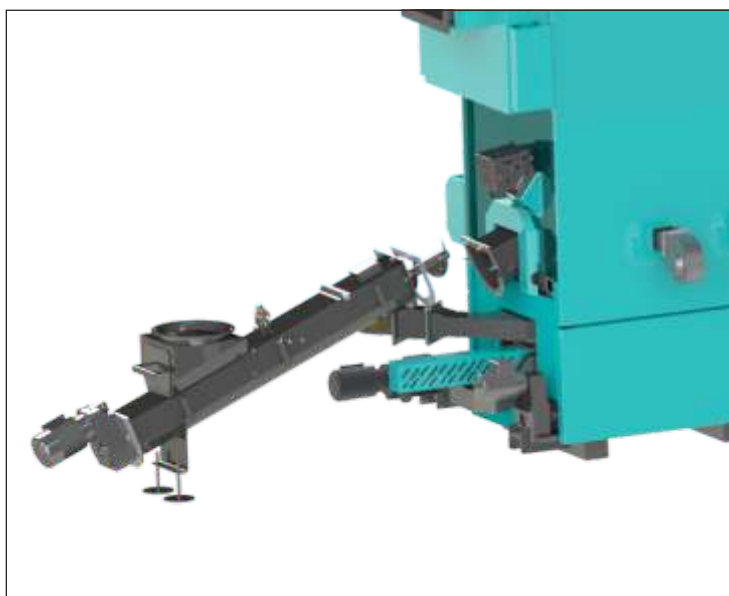
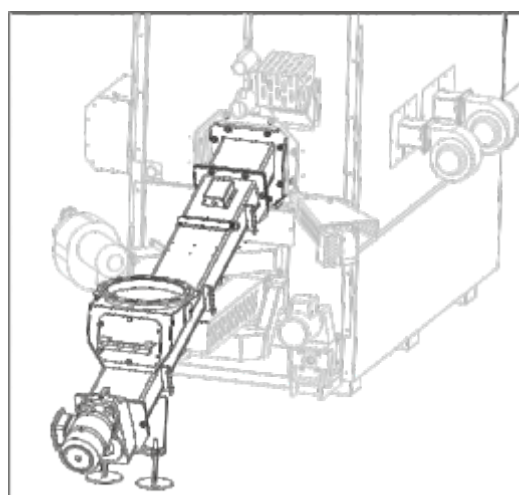
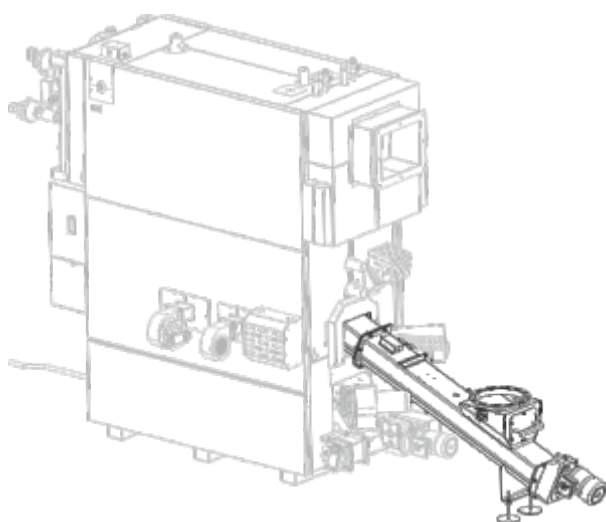
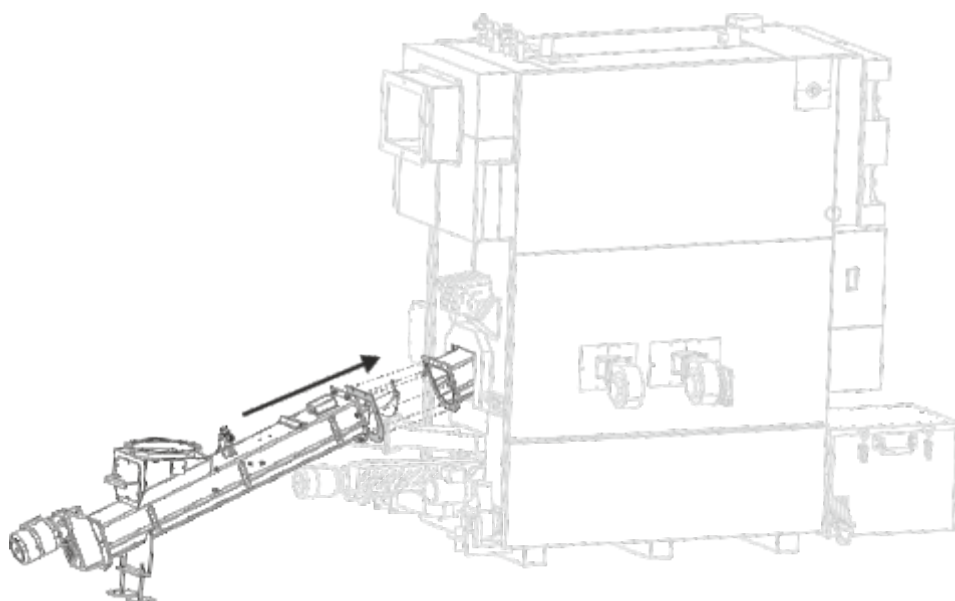

1.10. INSTALLATION OF CYCLONES AND CONNECTING FLUE ELEMENTS ON THE BOILER

1a) When the cyclone is installed on the left side of the boiler

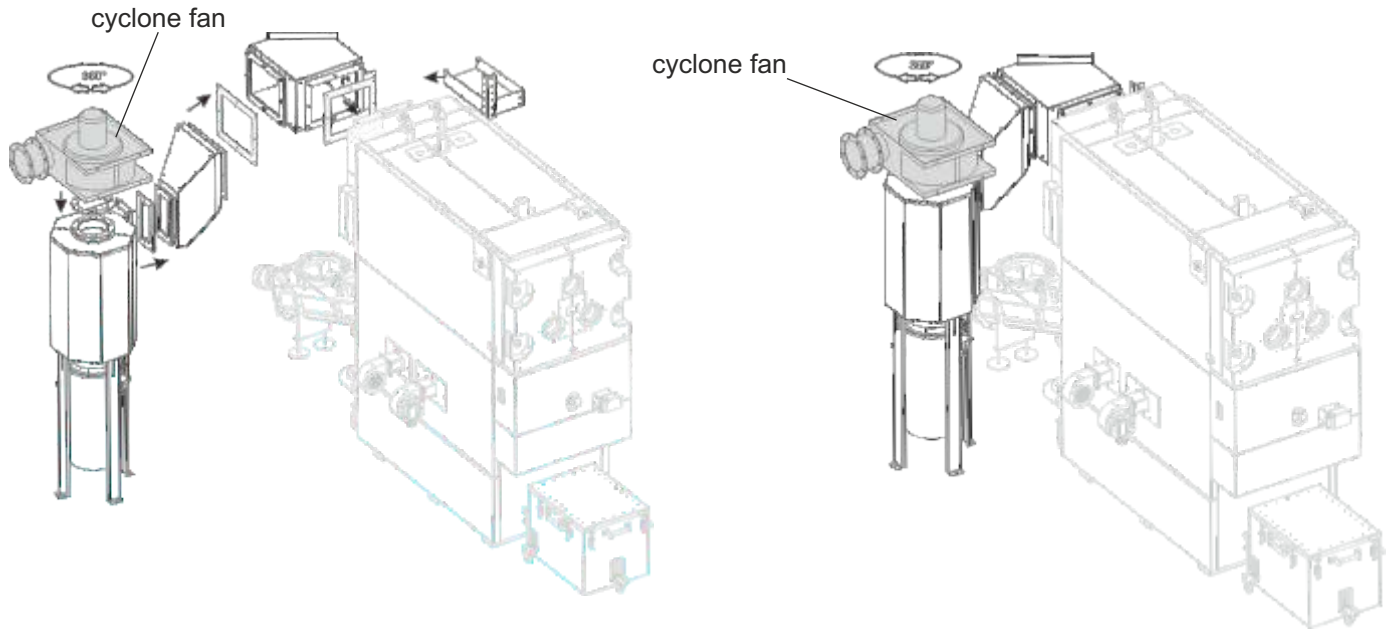

1b) When the cyclone is installed on the right side of the boiler

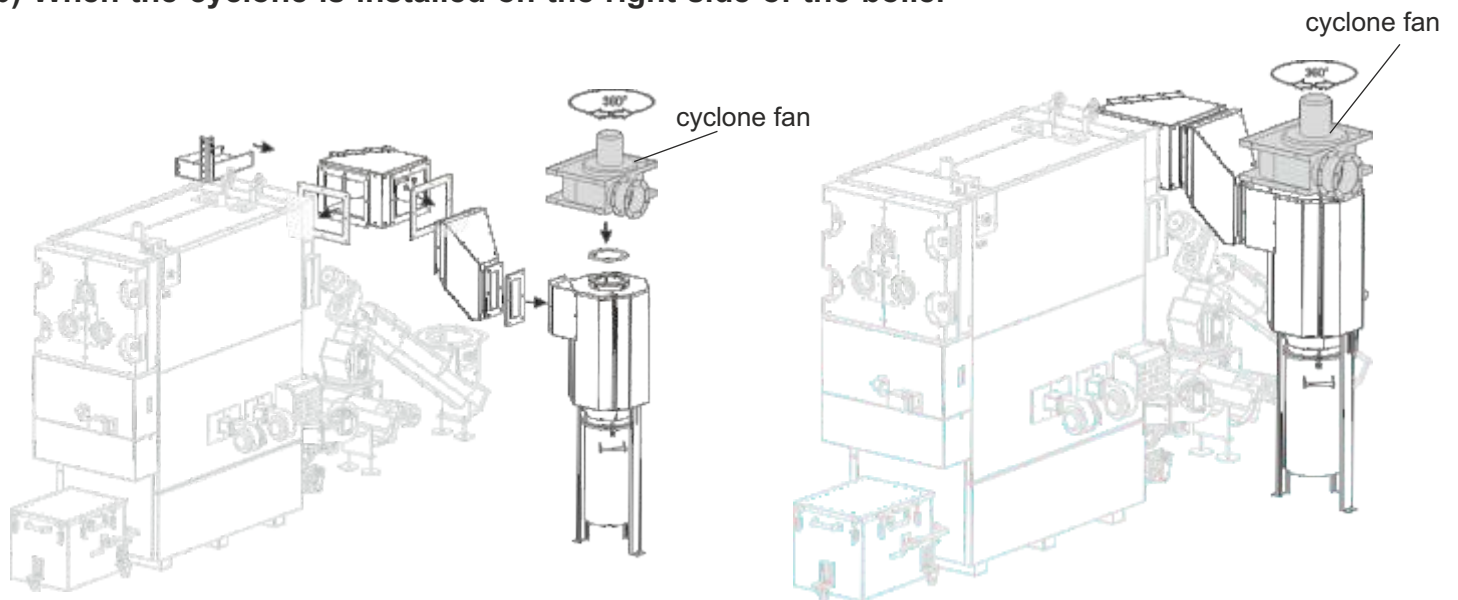

2a) Earthing Jumpers – status of delivery

On delivery, the earthing jumpers is located in three different places on the boiler (1, 2, 3) and separately in the nylon bag (for cyclone earthing) (4). They need to be removed so that the parts of boiler can be joined.

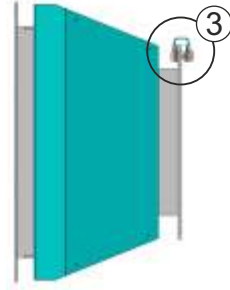
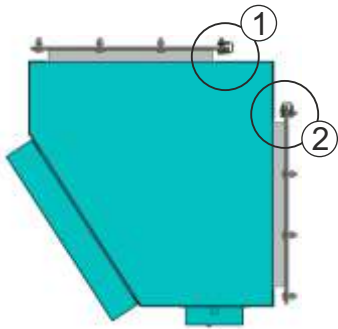

2b) Earthing Jumpers – installation

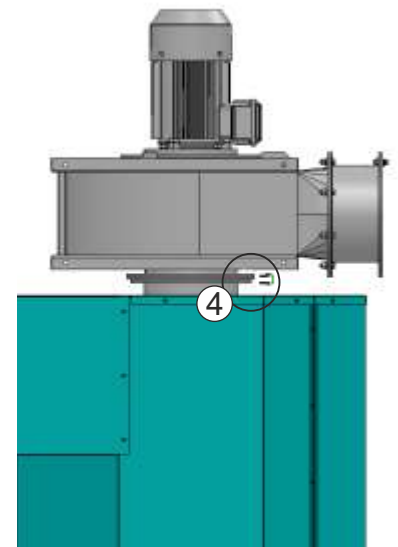
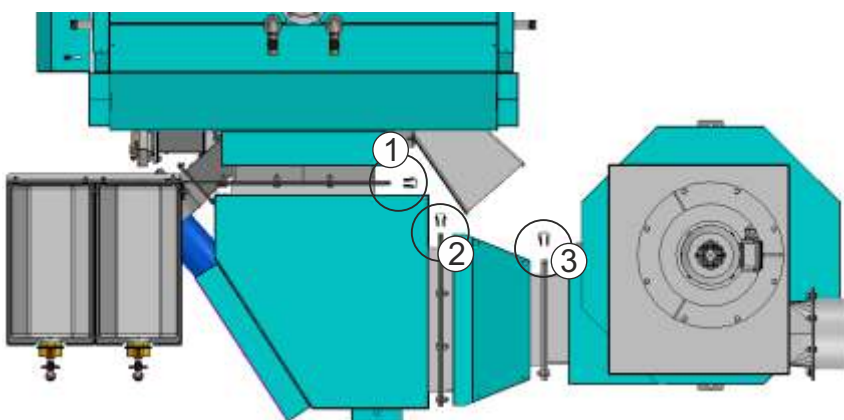
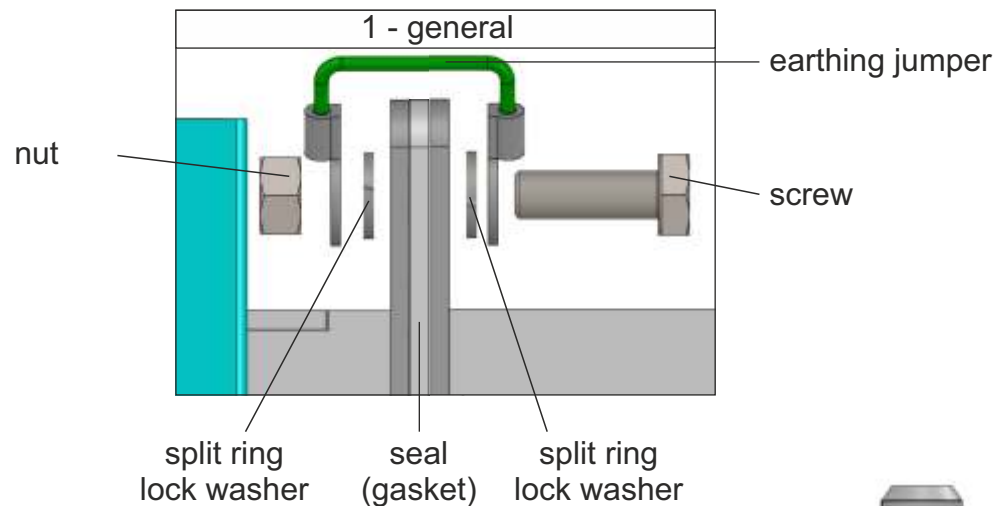

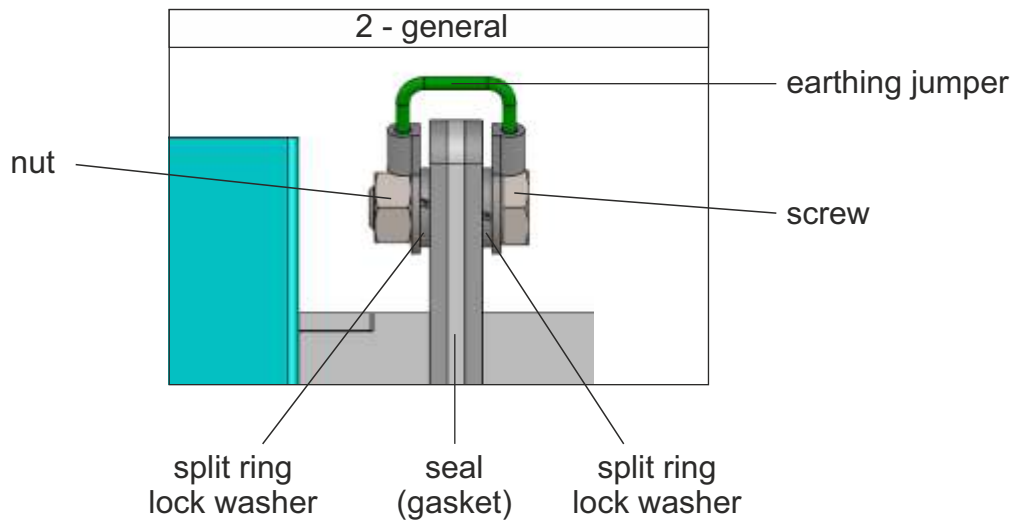

Fasten the earthing jumpers well at all places.

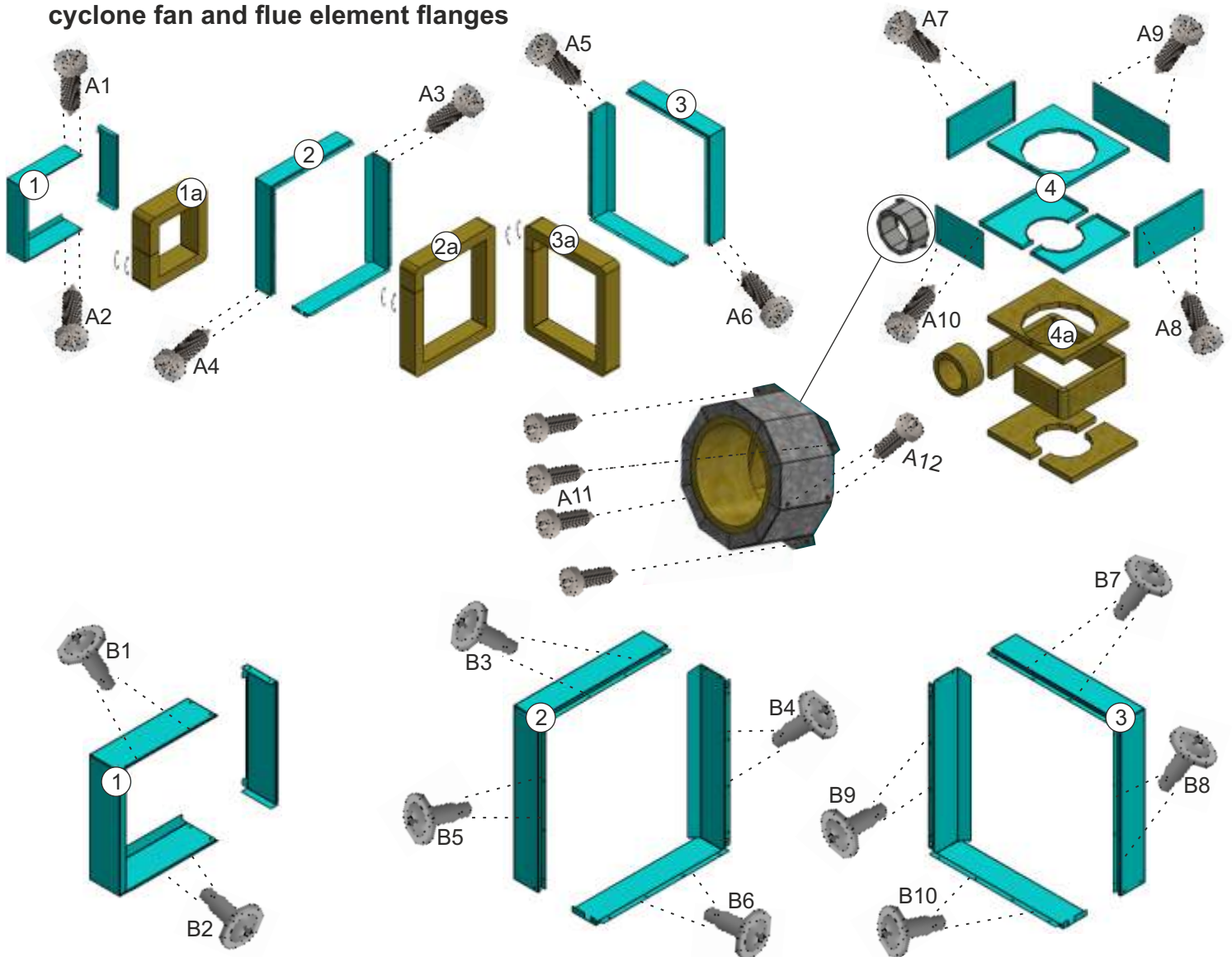

3) Installation of thermal insulation and sheet metal cover on the cyclone fan and flue element flanges

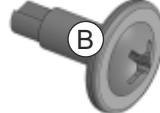

	Assembling the sheet metal cover of flue elements flange during installation.						Connecting the sheet metal cover of flue elements flange to the existing sheet metal cover.					
	 3.9 x 9.5						 4.2 x 13					

EKO-CKS Multi Plus	A1 / A2 (pcs.)	A3 / A4 (pcs.)	A5 / A6 (pcs.)	A7 / A8 (pcs.)	A9 / A10 (pcs.)	A11 / A12 (pcs.)	B1 (pcs.)	B2 (pcs.)	B3 / B4 (pcs.)	B5 / B6 (pcs.)	B7 / B8 (pcs.)	B9 / B10 (pcs.)
170	2 / 2	2 / 2	2 / 2	8 / 8	10 / 6	4 / 2	2	2	3 / 3	2 / 3	3 / 2	3 / 3
250	2 / 2	2 / 2	2 / 2	8 / 8	10 / 6	4 / 2	2	2	3 / 3	3 / 3	3 / 3	3 / 3
340	2 / 2	2 / 2	2 / 2	8 / 8	10 / 6	4 / 2	2	2	3 / 3	3 / 3	3 / 3	3 / 3
450	2 / 2	2 / 2	2 / 2	8 / 8	10 / 6	4 / 2	3	3	4 / 4	4 / 4	4 / 4	4 / 4
580	2 / 2	2 / 2	2 / 2	8 / 8	10 / 6	4 / 2	3	3	4 / 4	4 / 4	4 / 4	4 / 4

Route the fan motor cable through the slit on the sheet metal cover.

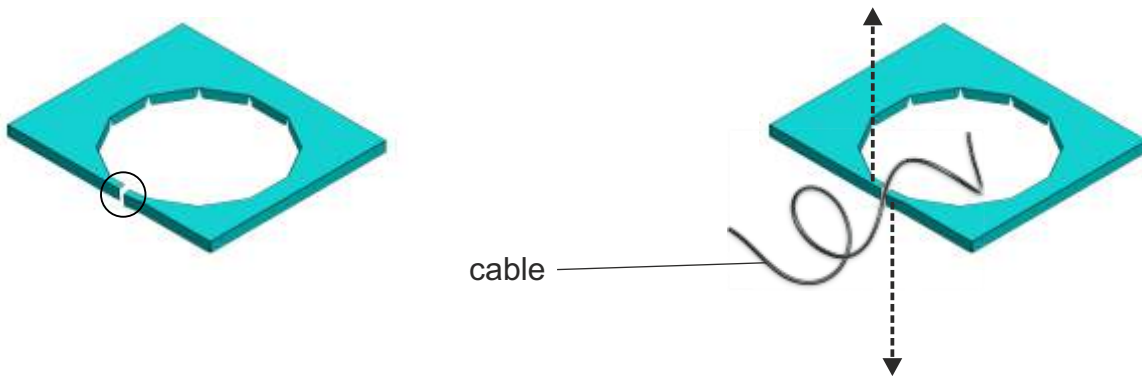

3a) Cyclone installed on the left side of the boiler

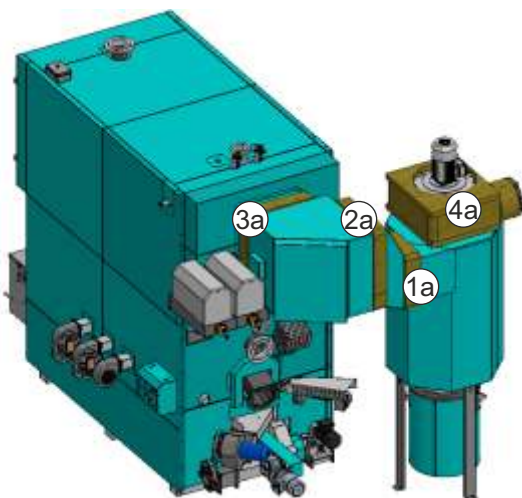

3b) Cyclone installed on the right side of the boiler

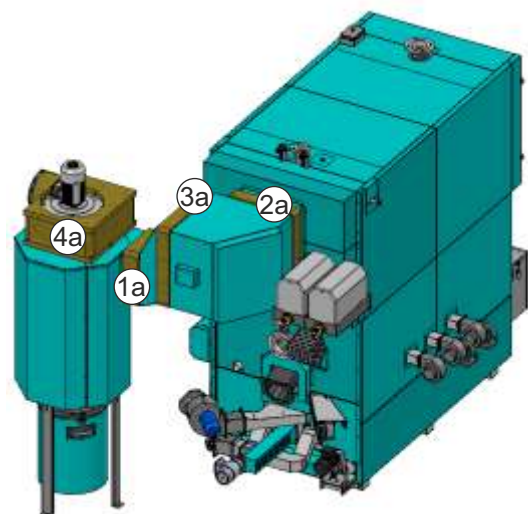

Boiler assembly

Depending on the side of the installed cyclone, the perforated part for the water tank supports needs to be removed.

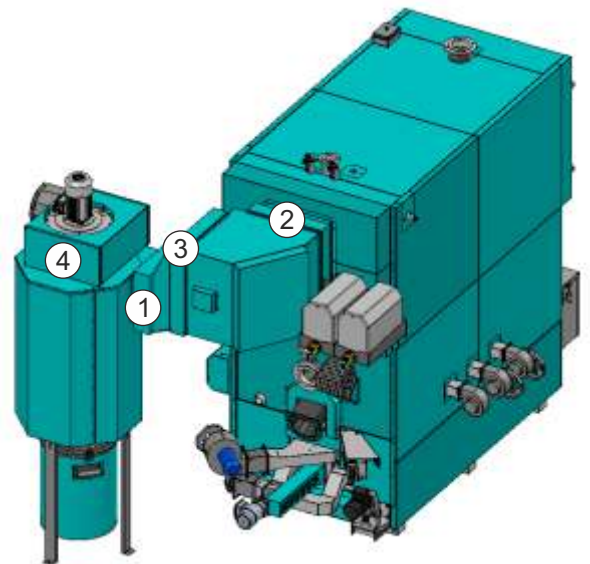
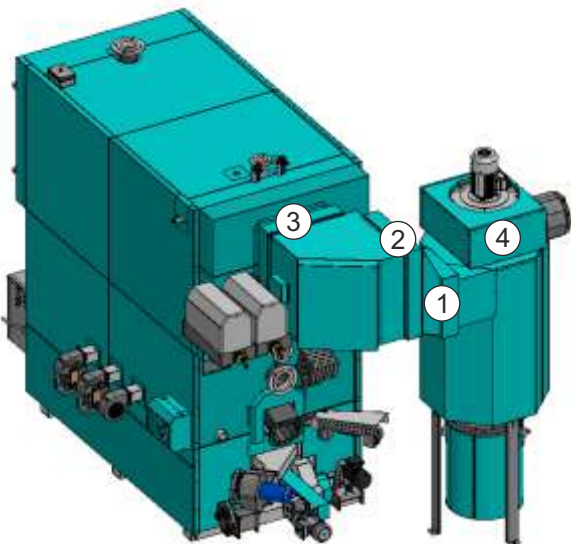
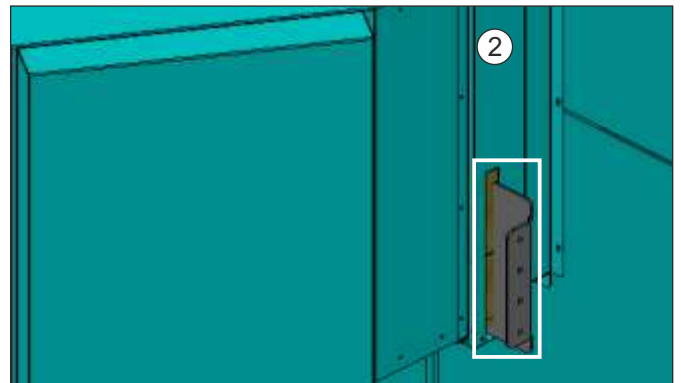
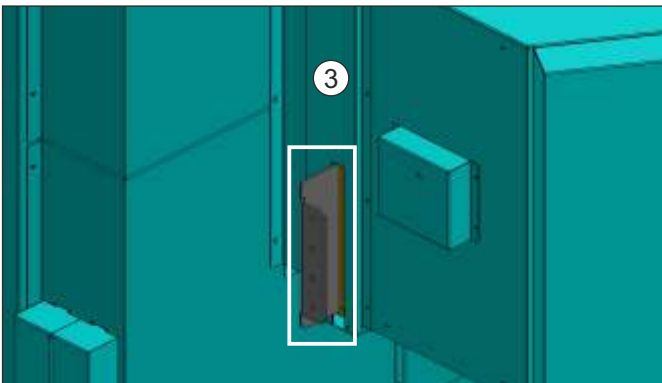
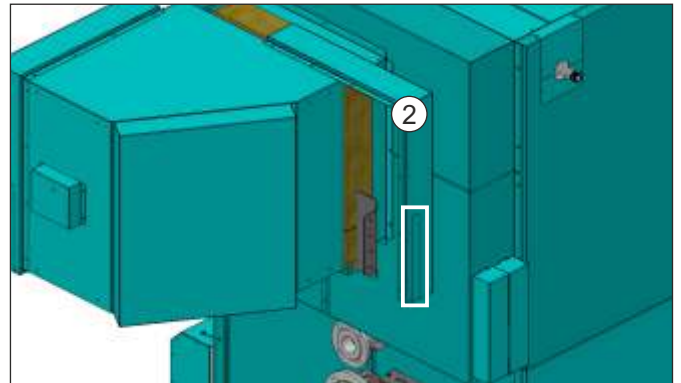
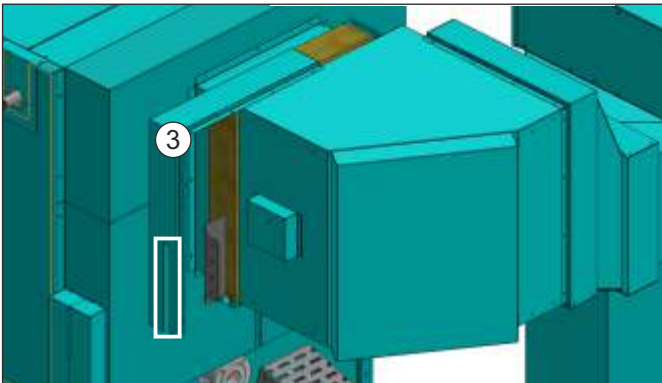
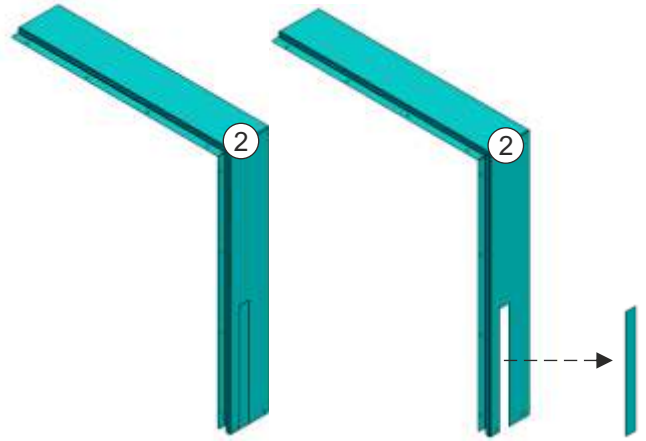
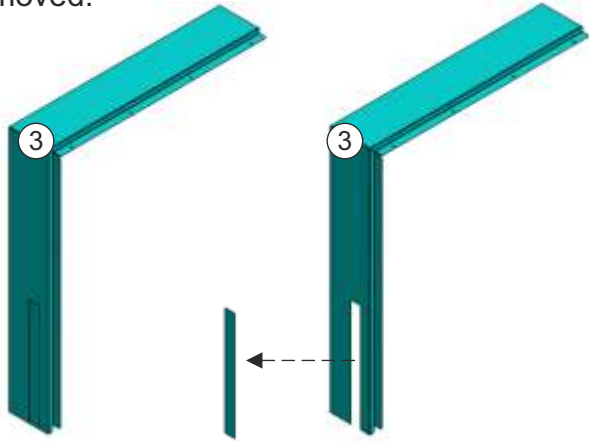

1.11. ASSEMBLY OF SCREW CONVEYOR 2

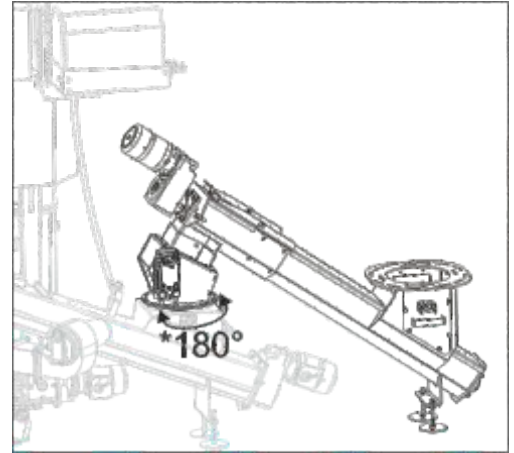
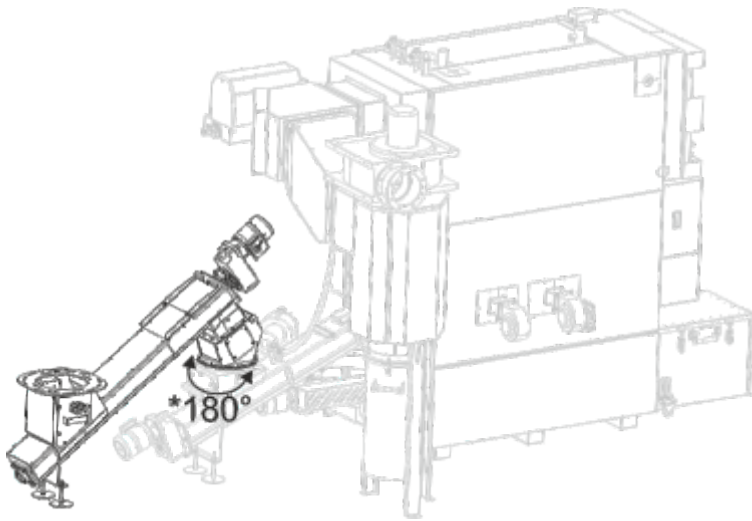

*possible angle of conveyor installation depend about side where is cyclone mounted

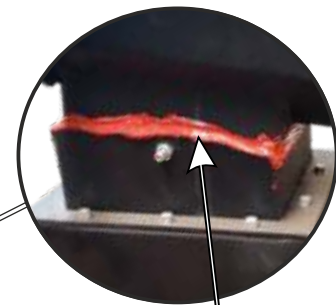
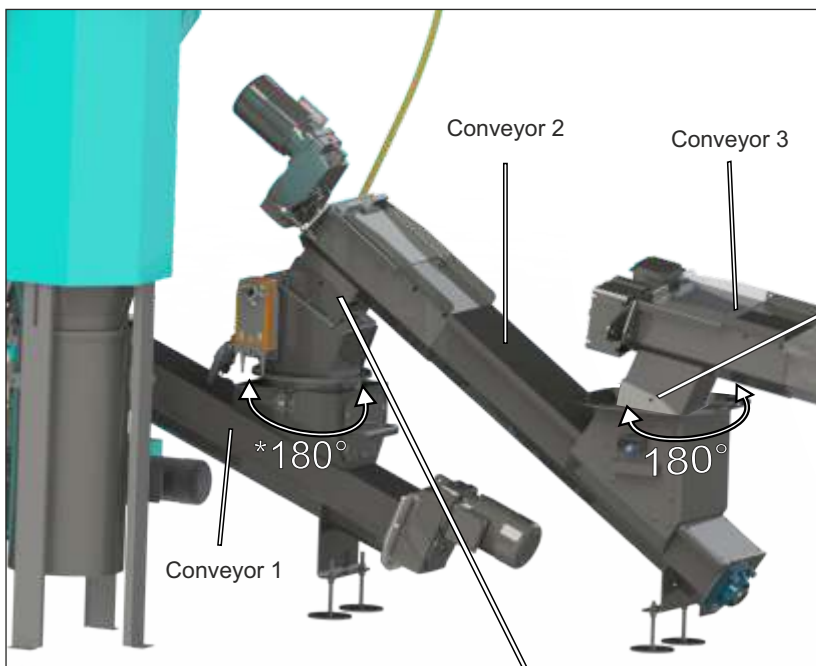

Must be sealed with red silicone sealant

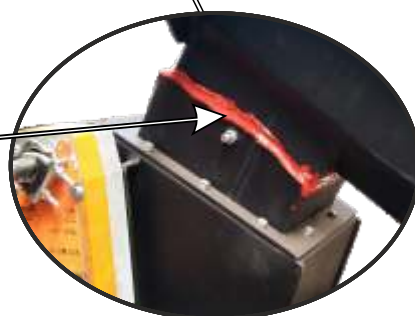

Must be sealed with red silicone sealant

1.12. CONVEYOR FOR EXTRACTION OF ASH

- View for 250, 340, 450, 580 kW (170 kW there is only one conveyor)

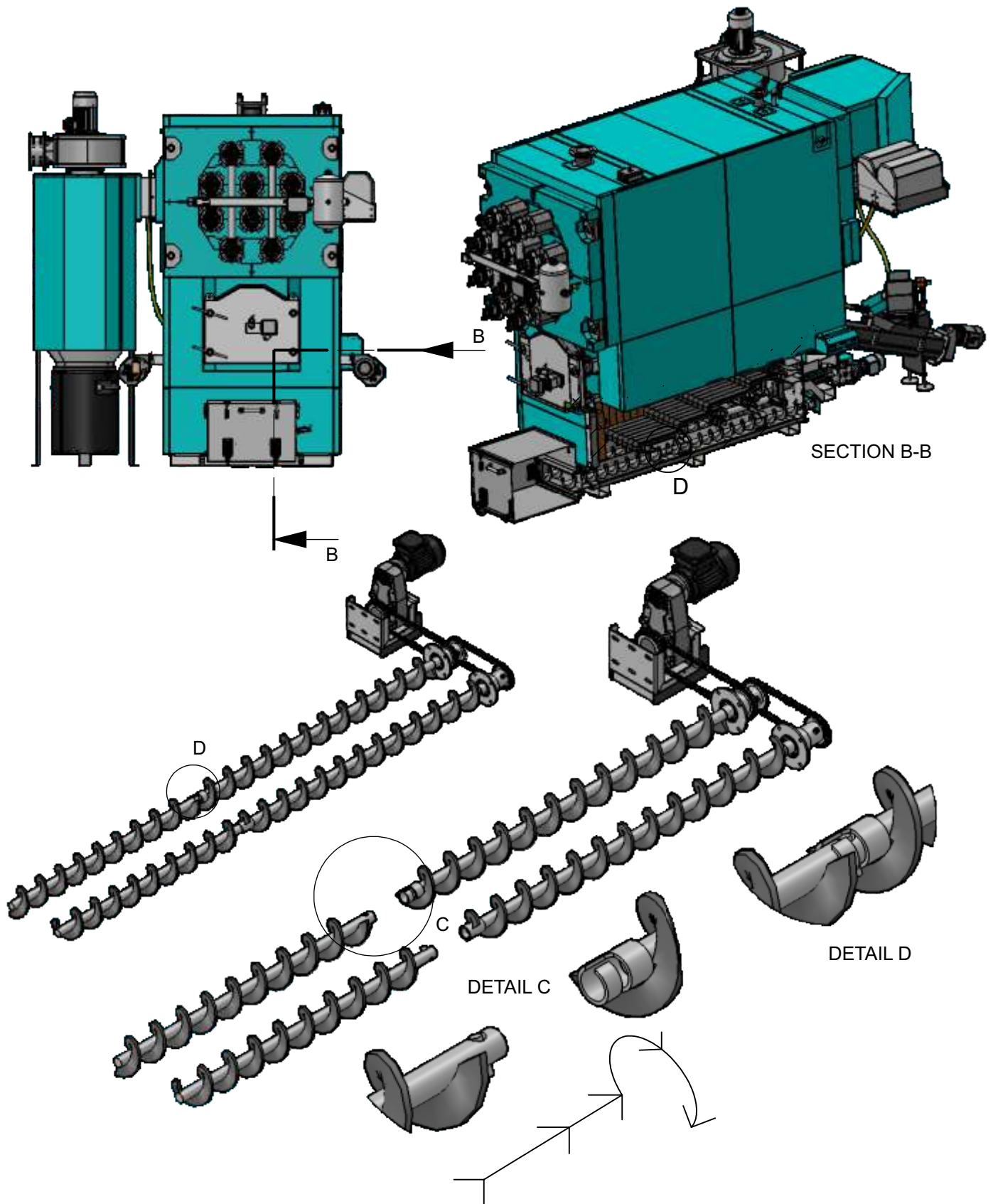

1.13. FLAP FIREBOX - MICROSWITCHES

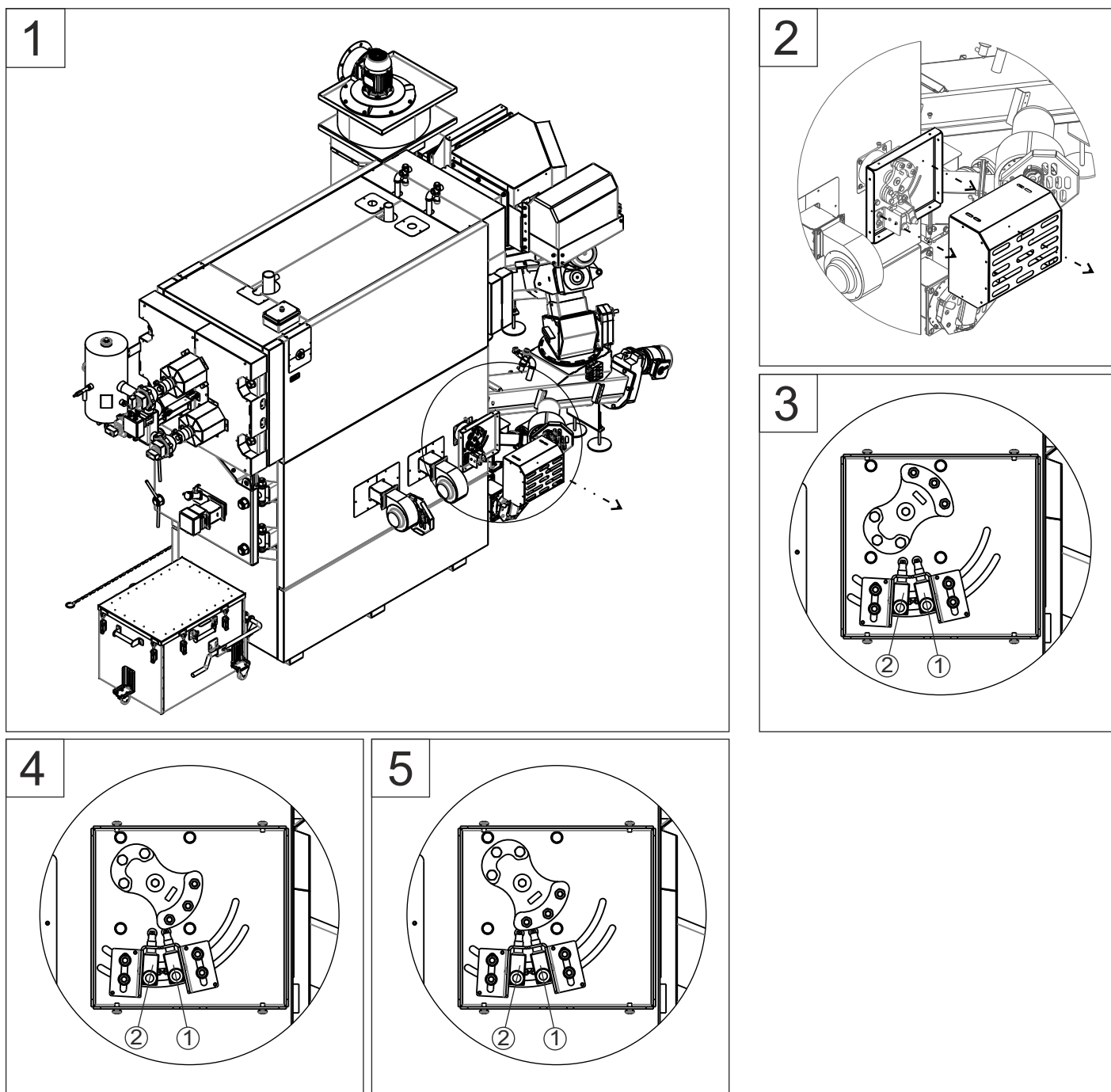

1. Location of boiler flap microswitches.
2. Detail of removal cover of the flap microswitches.
3. Status of the flap microswitch when the flap is not raised (no microswitch is pressed).
4. Microswitch-1 is pressed. The firebox flap is raised when it presses the first microswitch, a bunch with a blue arrow appears on the control unit screen (pictured in the boiler, see picture a), and information I5 is in HISTORY. The boiler conveyors stop working while the microswitch-1 is pressed.
5. Microswitch-1 and microswitch-2 are pressed. The firebox flap is raised when it presses the first and second microswitches, a bunch with a red arrow appears on the control unit screen (pictured in the boiler, see picture b) and an error is displayed "E119 – FUEL TOO HIGH" and ejects the "DI" and "F2" automatic electrical fuses (see image c) in the boiler's electrical cabinet. Conveyors can only be operated if the flap stops pressing at least the micro-switch-2 and if the enabled automatic electrical fuses "DI" and "F2" in the el. boiler cabinet.

a) Bunch with a blue angular arrow

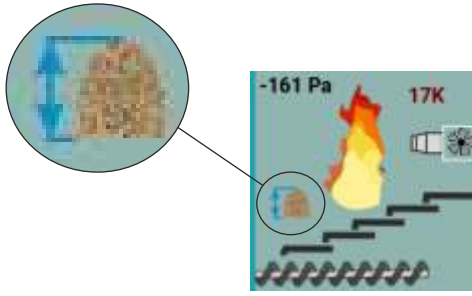

b) Bunch with a red angular arrow

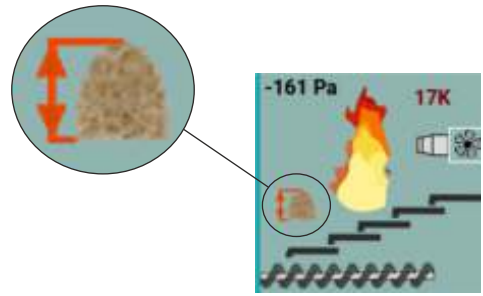

c) Fuses in the boiler electrical cabinet

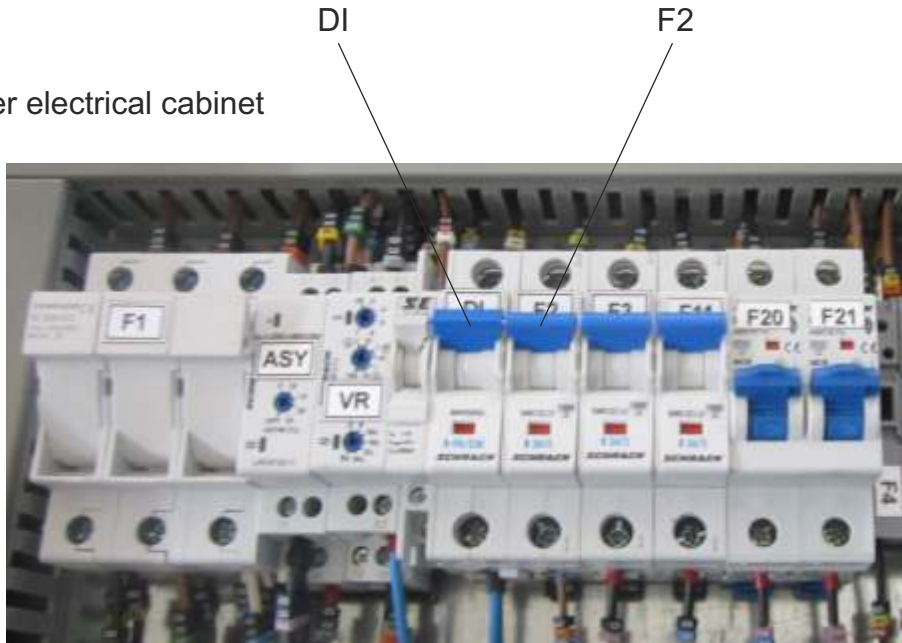

ELECTRICAL COMPONENTS OVERVIEW

	EKO-CKS Multi Plus	170	250	340	450	580
1	Cyclone fan	1×0,55 [kW], 400 V	1×1,1 [kW], 400 V	1×1,1 [kW], 400 V	1×2,2 [kW], 400 V	1×2,2 [kW], 400 V
2	Conveyor 1 motor device	1×0,55 [kW], 400 V	1×0,55 [kW], 400 V	1×0,55 [kW], 400 V	1×0,55 [kW], 400 V	1×0,55 [kW], 400 V
3	Ash cleaner motor device	1×0,18 [kW], 400 V	1×0,18 [kW], 400 V	1×0,18 [kW], 400 V	1×0,18 [kW], 400 V	1×0,18 [kW], 400 V
4	Primary air fan	1×0,18 [kW], 400 V	1×0,18 [kW], 400 V	1×0,18 [kW], 400 V	1×0,25 [kW], 400 V	1×0,25 [kW], 400 V
5	Primary air 2 lid motor device	1×0,0015 [kW], 230 V	1×0,0015 [kW], 230 V	1×0,0015 [kW], 230 V	1×0,0015 [kW], 230 V	1×0,0015 [kW], 230 V
6	Primary air 1 lid motor device	1×0,0015 [kW], 230 V	1×0,0015 [kW], 230 V	1×0,0015 [kW], 230 V	1×0,0015 [kW], 230 V	1×0,0015 [kW], 230 V
7	Secondary air fan	4×0,083 [kW], 230 V	4×0,083 [kW], 230 V	2×0,083 [kW], 230 V	6×0,083 [kW], 230 V	8×0,083 [kW], 230 V
8	Secondary air lid motor device	2×0,0015 [kW], 230 V	2×0,0015 [kW], 230 V	2×0,0015 [kW], 230 V	4×0,0015 [kW], 230 V	6×0,0015 [kW], 230 V
9	Movable grate motor device	1×0,090 [kW], 400 V	1×0,090 [kW], 400 V	1×0,090 [kW], 400 V	1×0,090 [kW], 400 V	1×0,090 [kW], 400 V
10	Electric heater	1×1,6 [kW], 230 V	1×1,6 [kW], 230 V	1×1,6 [kW], 230 V	1×1,6 [kW], 230 V	1×1,6 [kW], 230 V
11	Against flame protection motor device	1×0,0065 [kW], 230 V	1×0,0065 [kW], 230 V	1×0,0065 [kW], 230 V	1×0,0065 [kW], 230 V	1×0,0065 [kW], 230 V
12	Motor device of 3-way mixing valve	1×0,005 [kW], 230 V	1×0,005 [kW], 230 V	1×0,005 [kW], 230 V	1×0,005 [kW], 230 V	1×0,005 [kW], 230 V

2.0. SENSORS

①⑧⑨⑩ Sensor NTC 5k/25°C



② Photocell



③ Pressure switch (Huba Control)



④⑥ Sensor Pt1000



⑤ Lambda probe



① Safety thermostat STB (110-6°C)



⑦ Backfilling sensor



⑪ Fuel level sensor



Figure Sensors positions

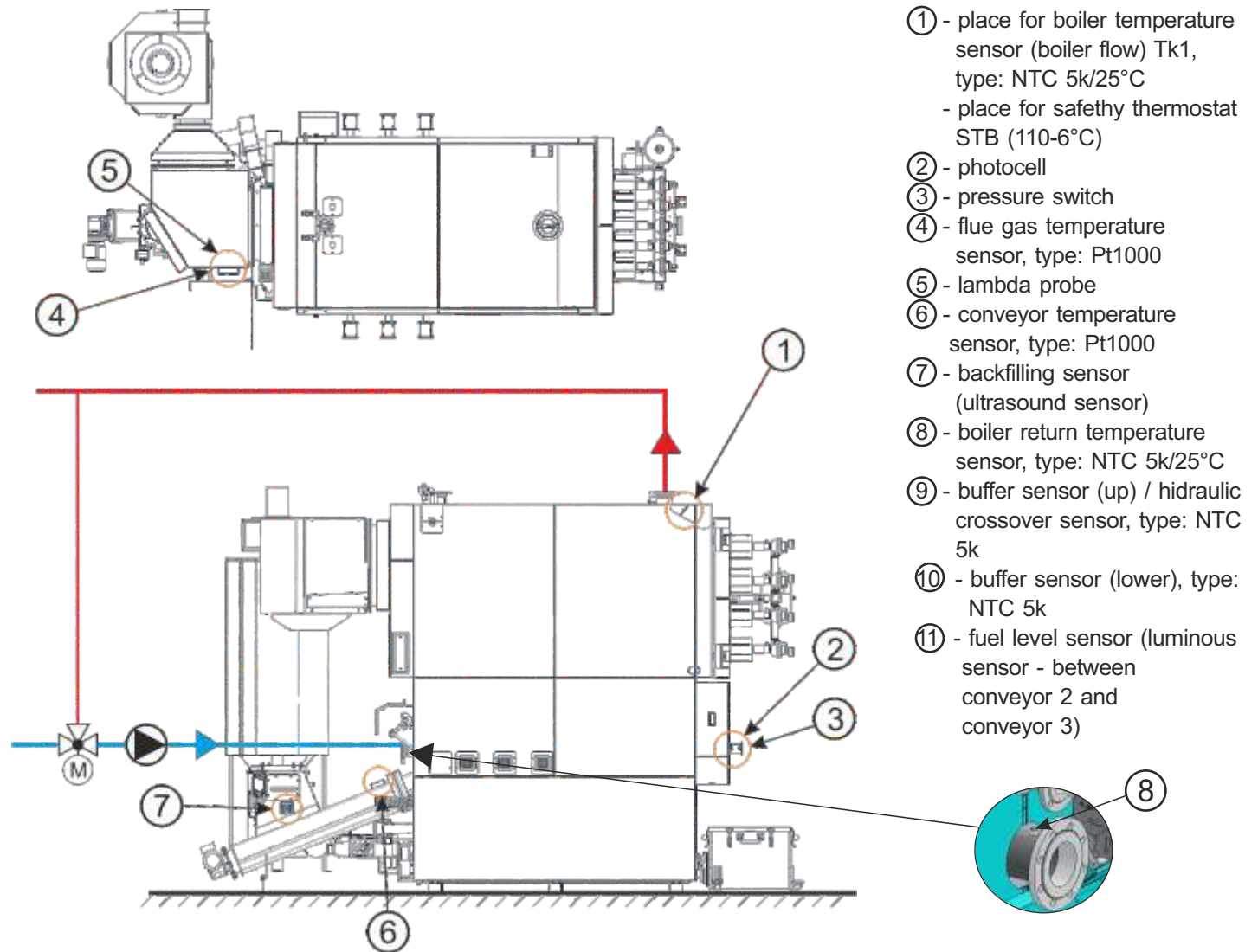

BUFFER TANK (CAS)

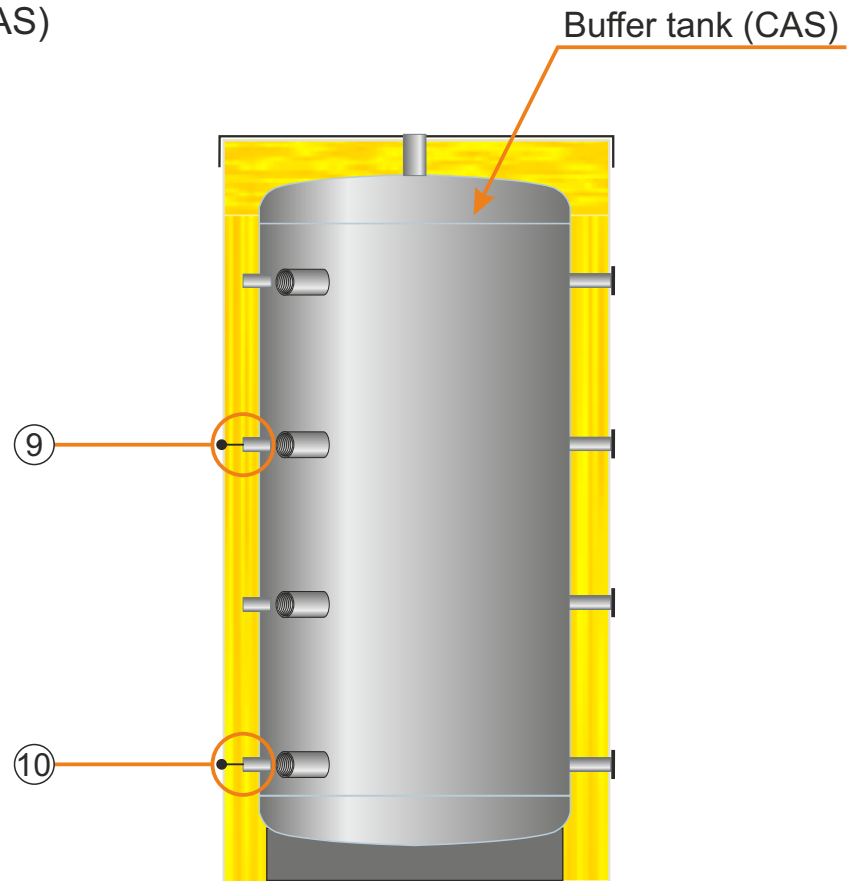

- ⑨ - Buffer tank sensor (up)
- ⑩ - Bufer tank sensor (lower)

2.1. BACKFILLING SENSOR (ultrasound)

⑦ - Backfilling sensor (ultrasound) - between conveyor 1 and conveyor 2

POSITION OF ULTRASOUND SENSOR:

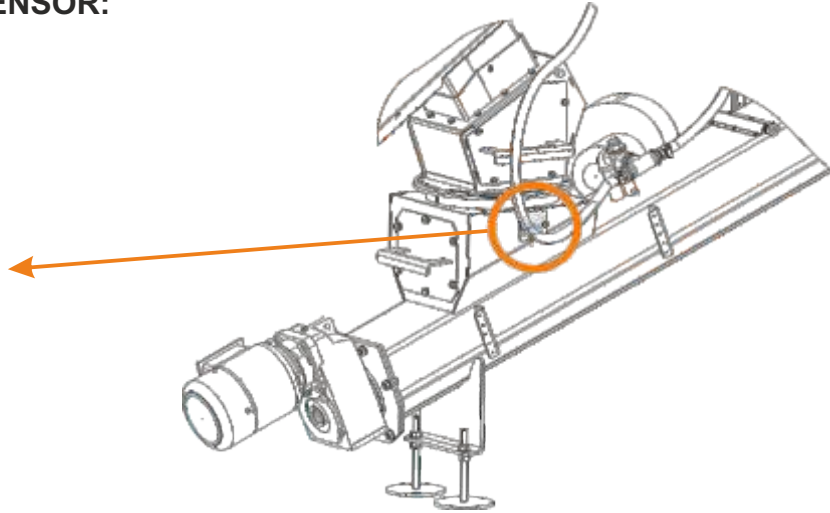

OPERATING WITH ULTRASOUND SENSOR

Ultrasound sensor can be operated by touch lense with feromagnetic tool (like screwdriver).



PROCEDURE OF ULTRASOUND SENSOR ADJUSTMENT

1. Turn off electrical supply on junction box.
2. Remove the sensor from the fuel supply (release the screws on sensor bracket).
3. Measure the inner width of the box through sensor opening (distance from sensor opening to the opposite side of box).
4. Turn on electrical supply on junction box.
5. On ultrasound sensor now light blue light (light will be lights five minutes - in that time sensor must be adjusted - otherwise turn off electrical supply on junction box, wait at least one minute and turn on electrical supply on junction box; ultrasound sensor will be again ready for adjustment).

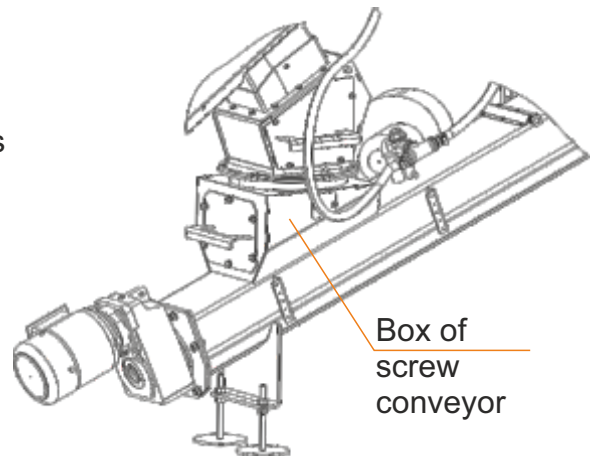

6. On the top of sensor, the green light is on. When you put the screwdriver on the sensor lens (on the blue light), orange light will light up and soon both lights (green and orange) will alternately blink. (If the lights do not start blinking for 2-3 seconds, remove the screwdriver and put it back.). Keep the screwdriver tilted until lights (which accelerate) blinking. The green light will turn on an the sensor is then reset to factory settings.
7. For next steps is necessary to have meter and some barrier (peace of paper, metal plate...). Place the meter on a flat surface or take the paper and mark previously measured distance. Set the sensor to the starting lin (start meter or drawn line). Set the barrier to te previously measured distance on the meter or the marked distance on the paper. Barrier must be placed vertically on the sensor. Put the screwdriver on te sensor lens (blue light) and hold it for 2-3 seconds, LED ligts on the sensor top will briefly stop and then start flashing alternately. (If the lights are not blinking, remove the screwdriver ant put it back in). When lights are blinking, remove the screwdriver and put it back on the lens (blue light) and remove it immediatly. When te lights stop flashing (after 7-8 seconds), only the green light will light. The sensor programmed the farthest measurement point.

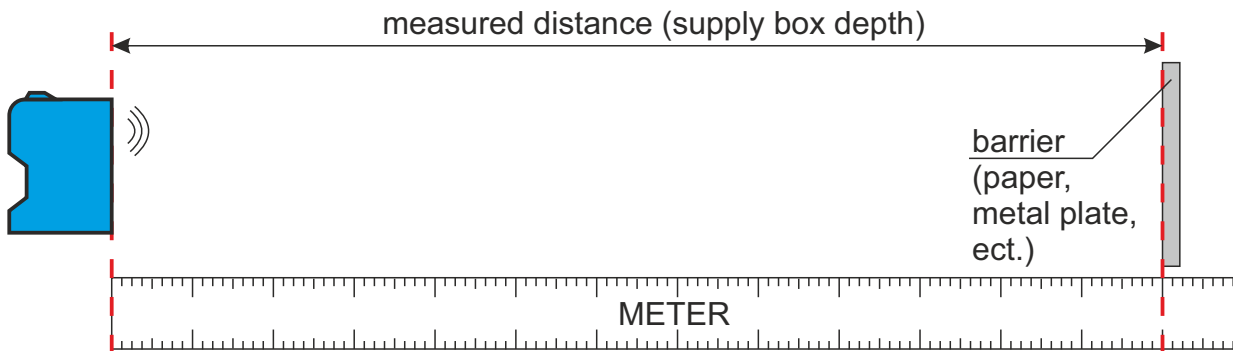

8. Put the barrier to the sensor and place the screwdriver on the lens (blue light). Both lights will blink and for 2-3 seconds LED lights on top of sensor will start blinking. (If the LED lights are not start blinking, remove the screwdriver and put it back in, previous action will not be lose). When the lights blinking, remove the screwdriver and put it back on the lens (blue light) and remove it immediatly. The lights will briefly stop and will continue to blink. The sensor programmed the nearest measurement point.

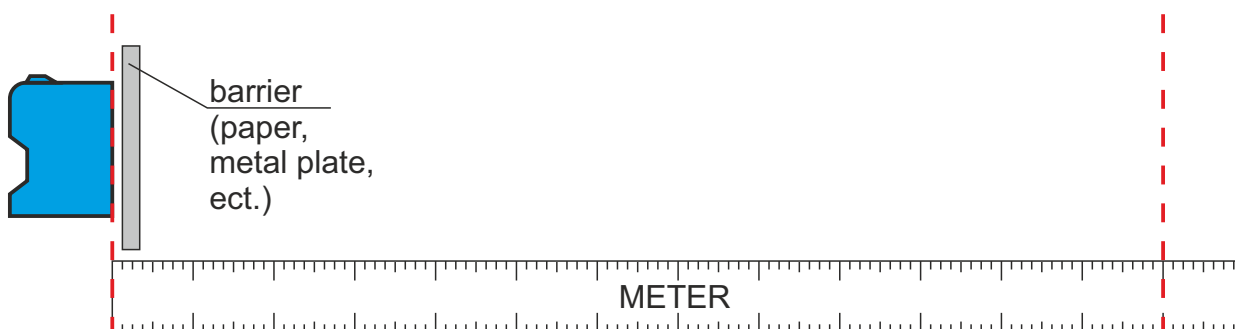

- The lights continue to blink, put the barrier to the measured distance and confirm the distance by tilting the screwdriver on the lens (blue light) and immediately move it away. The LED lights will stop momentarily and start blinking quickly. After the blinking stops and the green light is turned on, the sensor is programmed. Place the hand in front of the sensor at a distance smaller than the measured to see if the sensor is working properly. If the sensor registered the hand, the orange light will turn on on top of the sensor. When you remove the hand, the orange light will turn off and only the green light remains. If the sensor doesn't work as described, the sensor must be programmed from again from beginning.

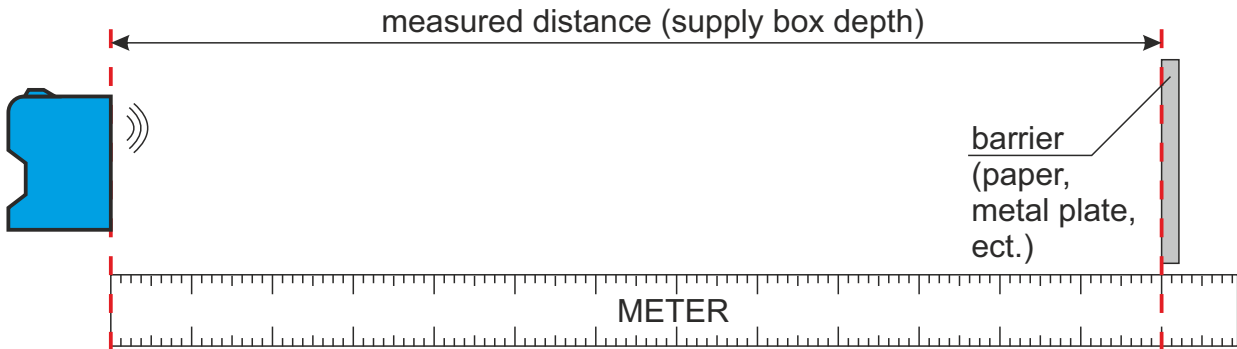

- Turn off the power supply on boiler junction box. Attach the sensor to the screw conveyor box. Turn on the power supply on boiler junction box.

2.2. FUEL LEVEL SENSOR (LUMINOUS)

- Backfilling sensor (luminous) - between conveyor 2 and conveyor 3

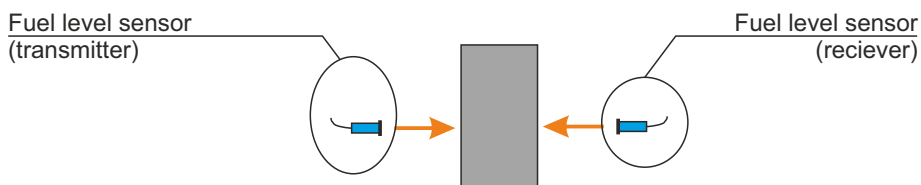
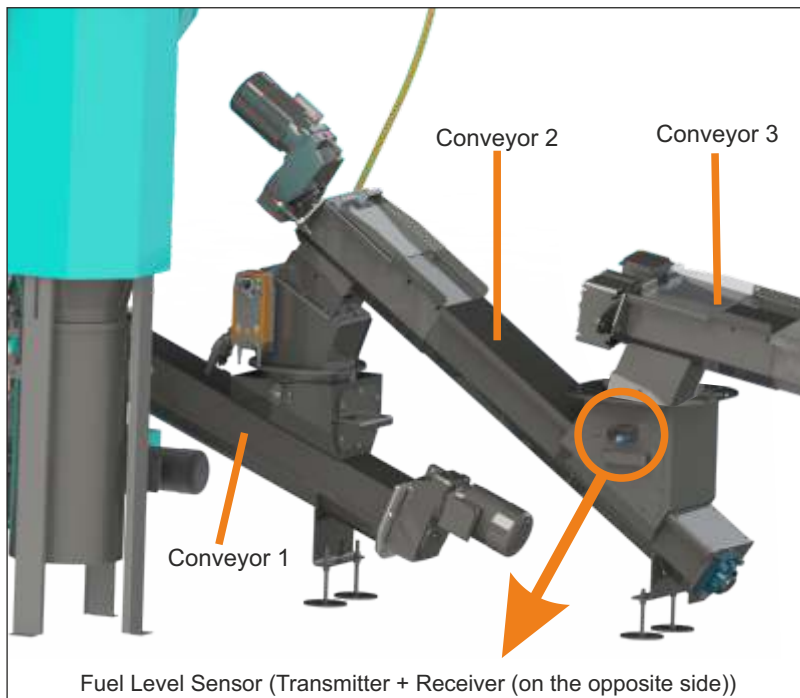

2.3. TABLE OF RESISTANCES OF THE SENSOR

RESISTANCE LIST Pt1000 SENSOR
(measuring field -30 - +400 °C)

Temperature (°C)	Resis. (W)	Temperature (°C)	Resis. (W)
-30	885	225	1.866
-25	904	230	1.886
-20	923	235	1.905
-15	942	240	1.924
-10	962	245	1.943
-5	981	250	1.963
0	1.000	255	1.982
5	1.019	260	2.001
10	1.039	265	2.020
15	1.058	270	2.040
20	1.077	275	2.059
25	1.096	280	2.078
30	1.116	285	2.097
35	1.135	290	2.117
40	1.154	295	2.136
45	1.173	300	2.155
50	1.193	305	2.174
55	1.212	310	2.194
60	1.231	315	2.213
65	1.250	320	2.232
70	1.270	325	2.251
75	1.289	330	2.271
80	1.308	335	2.290
85	1.327	340	2.309
90	1.347	345	2.328
95	1.366	350	2.348
100	1.385	355	2.367
105	1.404	360	2.386
110	1.424	365	2.405
115	1.443	370	2.425
120	1.462	375	2.444
125	1.481	380	2.463
130	1.501	385	2.482
135	1.520	390	2.502
140	1.539	395	2.521
145	1.558	400	2.540
150	1.578		
155	1.597		
160	1.616		
165	1.635		
170	1.655		
175	1.674		
180	1.693		
185	1.712		
190	1.732		
195	1.751		
200	1.770		
205	1.789		
210	1.809		
215	1.828		
220	1.847		

RESISTANCE LIST NTC 5k/25°C SENSOR
(measuring field from -20 - +130 °C)

Temperature (°C)	Resistance (Ω)
-20	48.535
-15	36.465
-10	27.665
-5	21.158
0	16.325
5	12.694
10	9.950
15	7.854
20	6.245
25	5.000
30	4.028
35	3.266
40	2.663
45	2.184
50	1.801
55	1.493
60	1,244
65	1.041
70	876
75	740,7
80	629,0
85	536,2
90	458,8
95	394,3
100	340,0
105	294,3
110	255,6
115	222,7
120	190,7
125	170,8
130	150,5

2.4. INSTALLATION HIGH AND LOW PRESSURE LIMITERS

BOILERS ≥ 300kW - standard delivery, necessarily installation
BOILERS < 300kW - delivery only as additional equipment

Parts supplied:

1. Ball valve G 1/2" for filling/draining
2. Manometer Φ 80 G 1/2" (0-6 bar)
3. Maximum pressure limiter Danfoss BCP3H (0-6 bar, G 1/2")
4. Minimal pressure limiter Danfoss BCP3L (0-6 bar, G 1/2")
5. Caleffi straight lockshield valve G 1/2"
6. Safety element tube 1
7. Safety element tube 2

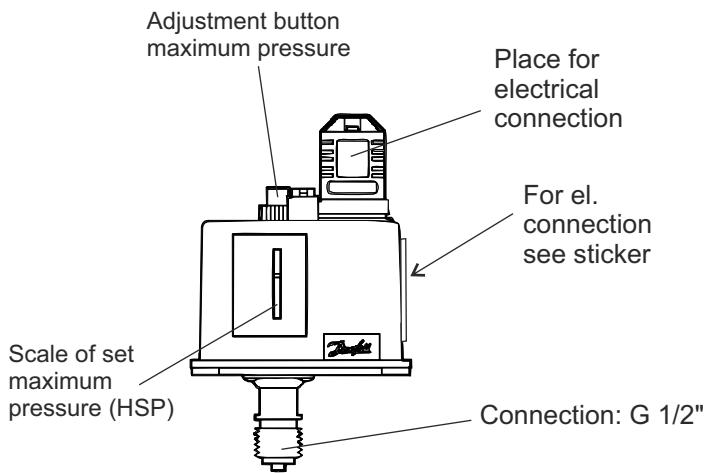
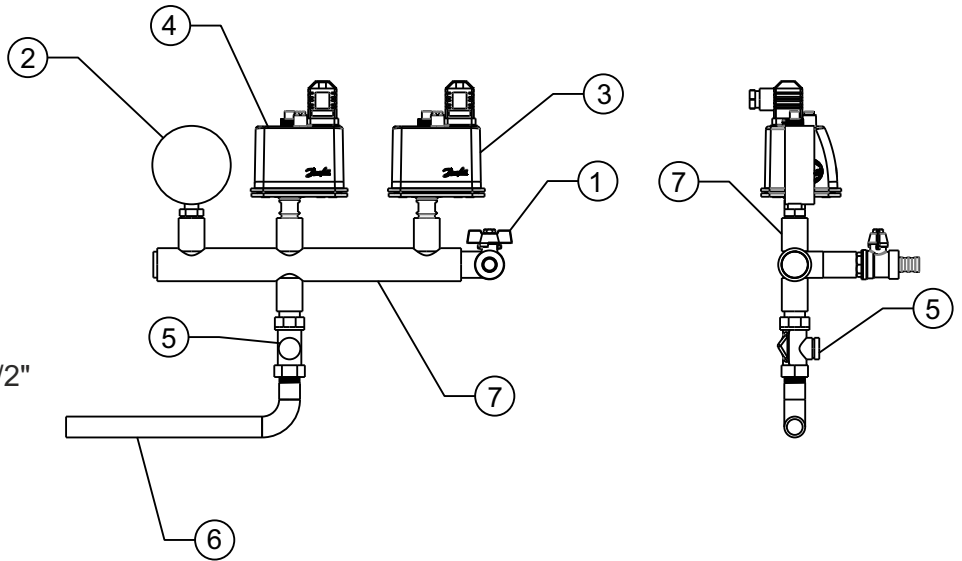

Danfoss BCP3H
Maximum pressure limiter
(limiter with manual reset)

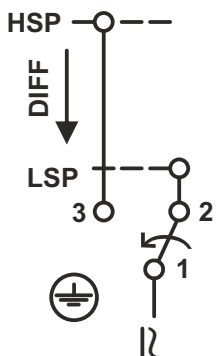

HSP -> the set cut-out value on RANGE scale
 LSP = HSP - DIFF -> the set cut-out value minus fixed pre-set differential value below which manual reset can be done
 Differential = 0.40 (bar)

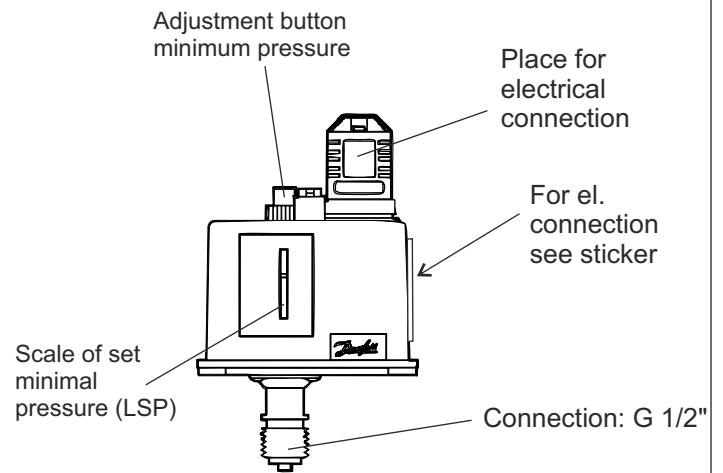

Danfoss BCP3L
Minimal pressure limiter
(limiter with manual reset)

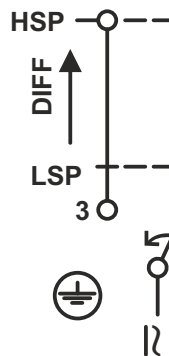

LSP -> the set cut-out value on RANGE scale
 HSP = LSP + DIFF -> the set cut-out value plus fixed pre-set differential value above which manual reset can be done
 Differential = 0.40 (bar)

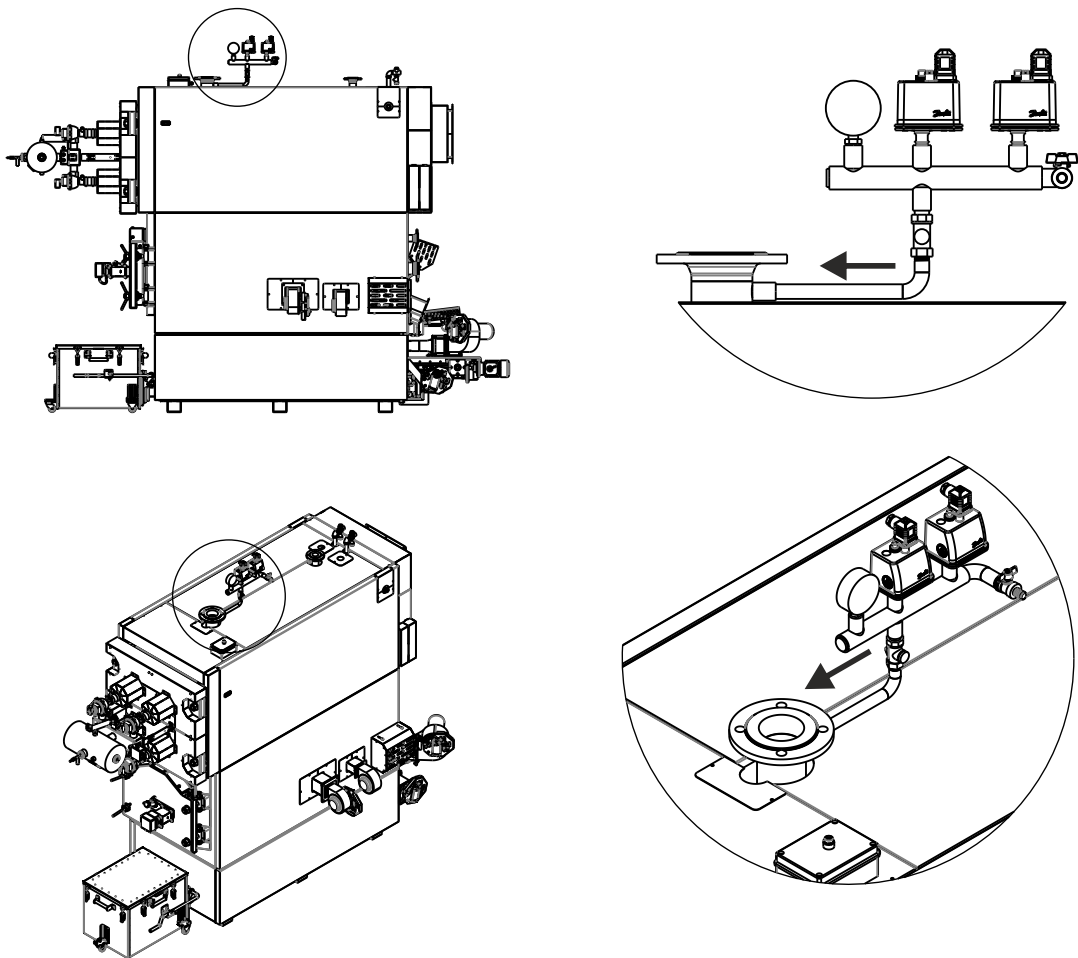
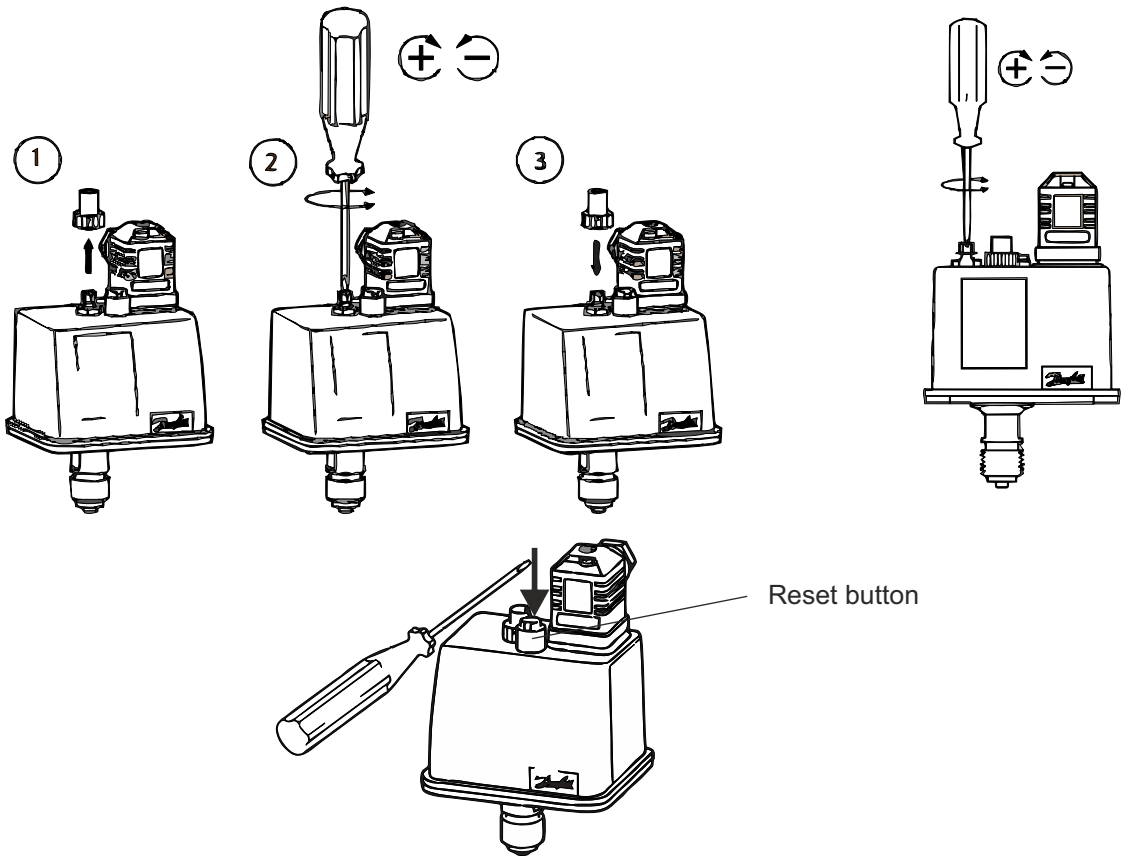

3.0. PROTECTION AGAINST RETURN FLAME

Protection against return flame in screw conveyor 1 (screw conveyor that brings wood chips / wood pellets in the boiler burner) is done by using protection lid against return flame located at the joint a screw conveyor (screw 1) and the feed screw conveyor from wood chips / wood pellets container.

Protection lid is opened and closed by an electric motor. Opening the valve starts when the circuit is closed and will remain open until the circuit is closed. With the opening of the circuit (power cut) protection lid closes without using power by using the spring located in electric engine. If power is lost when the boiler works, protection lid against return flame immediately started closing and remains so until the procedure of boiler control again closed circuit corresponding electric motor that opens the lid.

Situations in which a lid to protect against return flame is closed:

- during power failure.
- whenever screw conveyors except screw1 not have warrant for work (operating setting 0%).
- whenever regulation observed work error of the system which is printed on the screen.

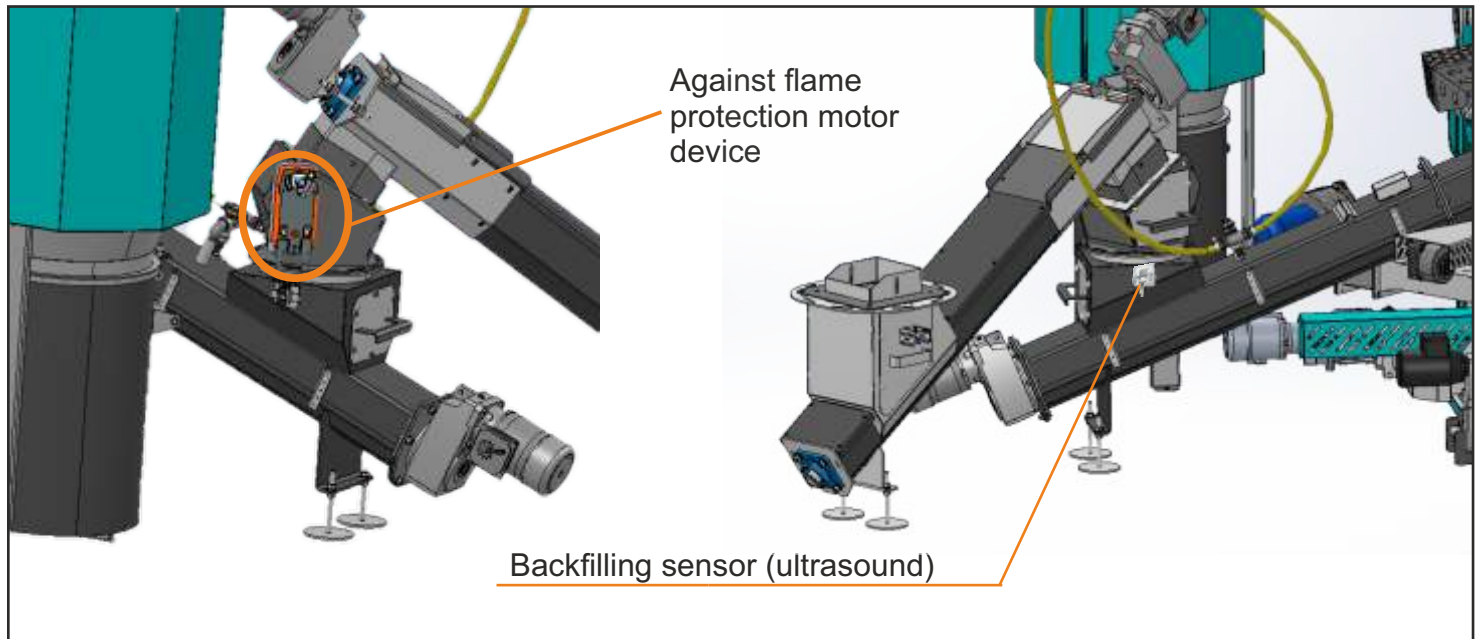

3.1. ADJUSTMENT OF BACKFIRE PROTECTION LID

MAIN PARTS:

- 1 - fuel supply box
- 2 - backfire protection lid
- 3 - backfire protection lid motor device

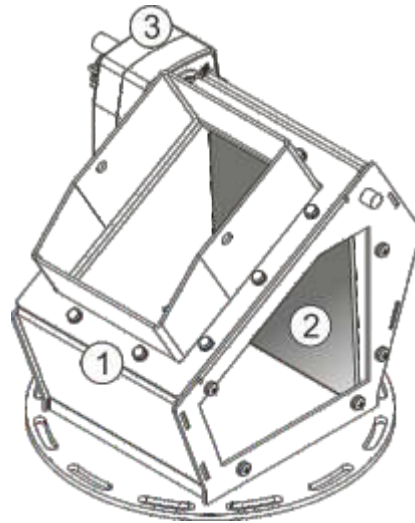

PROCEDURE OF BACKFIRE PROTECTION LID ADJUSTMENT

1. Turn of electrical supply on junction box.
2. Remove cover lid from fuel supply box.
3. Nuts on clam must be relaxed before the following actions.
4. Wind up return flame protection motor device in a way that rotate motor device handle counterclockwise and make three rounds. Hold the handle and pull the switch in position „LOCKED”.

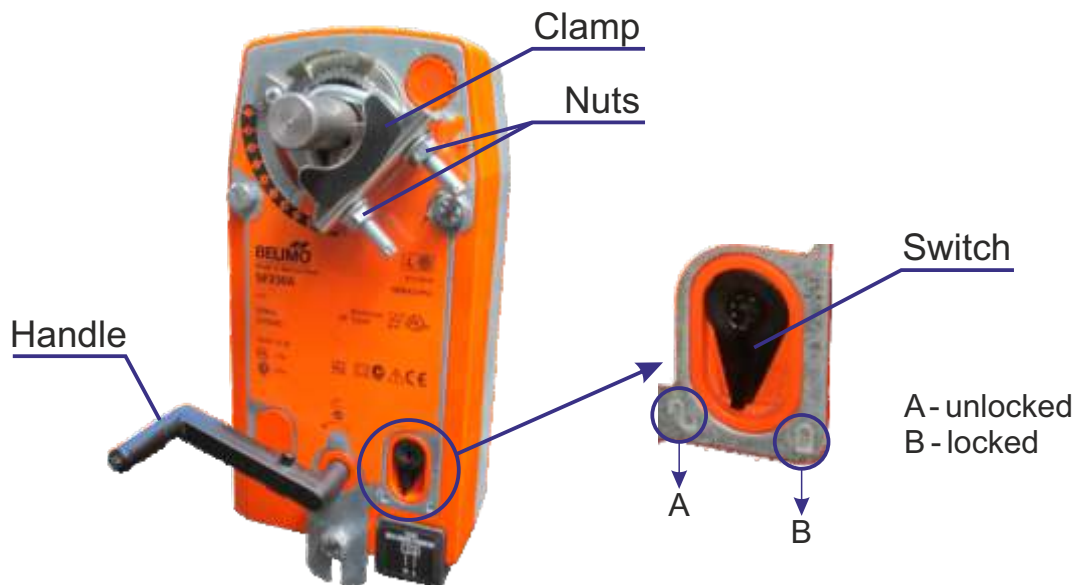

Protection against return flame

5. Take a lid with hand, lift it up to the top of fuel supply box and hold it. With other hand tight nuts on clamp. During tightening nuts make attention that lid must be on the center of fuel supply box.

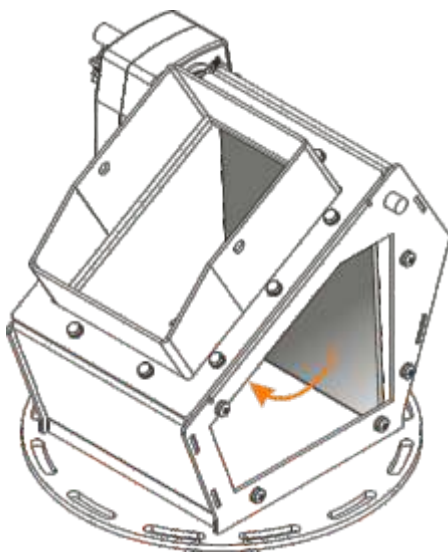

6. When is nuts tightened, lid must stand alone (without holding) on the top of fuel supply box.
7. Pull switch on motor device in position „UNLOCKED”. Motor device will be additionally press lid on top of the fuel supply box.

3.2. RETURN FLAME EXTINGUISHING ON CONVEYOR 1

Return flame extinguishing on conveyor 1 (screw conveyor that brings wood chips / wood pellets in the boiler burner) is done using a canister located above the conveyor 1. The canister is connected to tube with a thermic valve that opens the passage when its sensor (located in conveyor 1) sense a temperature of 95°C.

It is necessary to take care of the water level in the canister, and keep it full.

Figure 8. Return flame extinguishing in conveyor 1

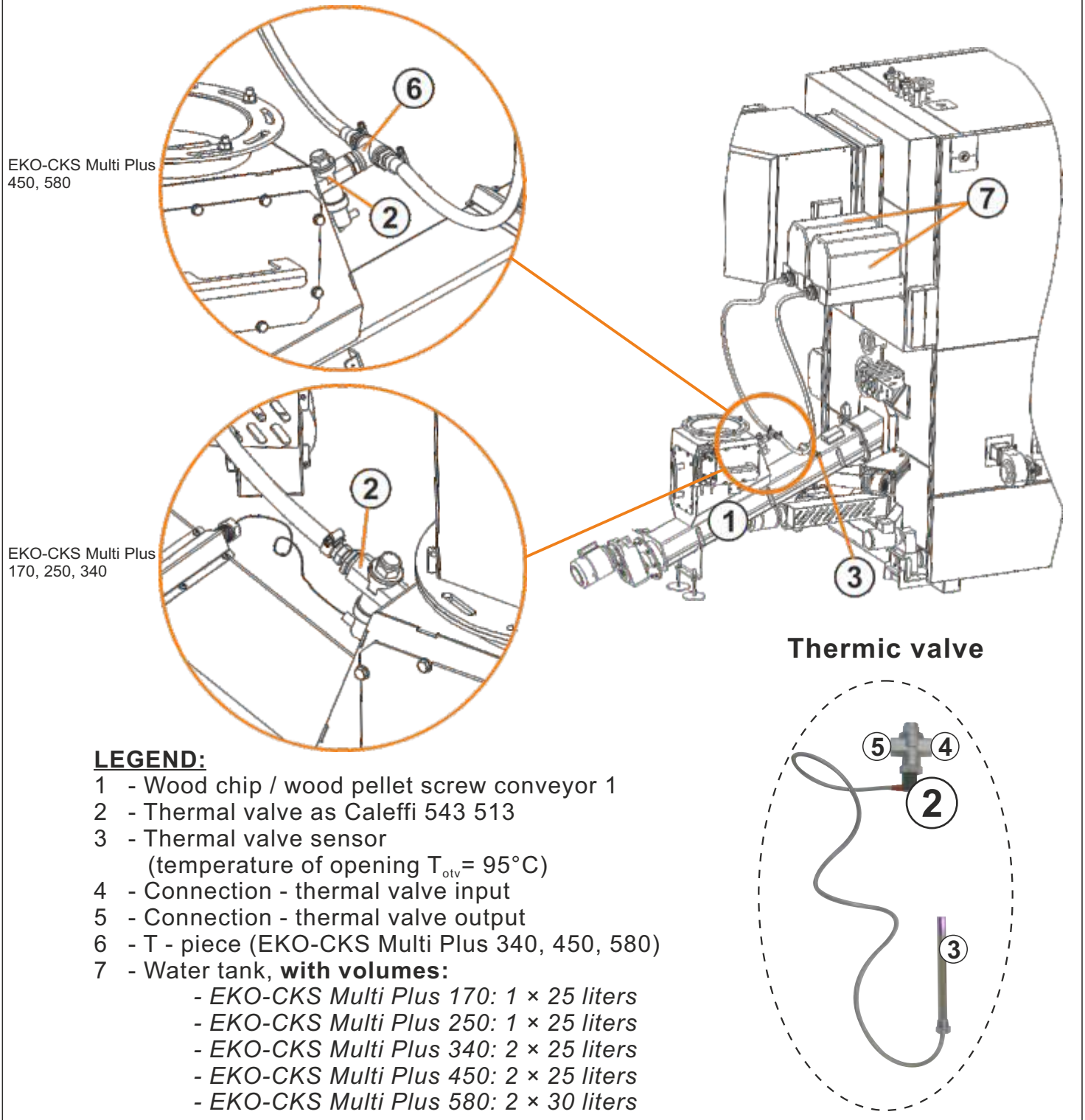

4.0. THERMAL PROTECTION

By European EN norms for the close heating system it is obligatory to mount the thermal safety protection of the boiler. The boiler is factory made for the installing of the thermal protection. If on the boiler which is mounted on the close heating system damage happens and it have some connection with the overheating of the boiler, and the boiler and the system do not have or have incorrect mounted thermal safety protection, the warranty is not valid. Thermal protection will be activated if boiler temperature exceed 103°C.

IMPORTANT:

The thermal safety protection is obligatory to be connect on the plumbing installation of the building charged from the plumbing, not from the water pressure tank, in situation when the failure of power supply happens there is the possibility of overheating the boiler and the water pressure tank is not in the position to insure the necessary quantity of the water.



THERMAL SAFETY PROTECTION MUST BE CONNECTED TO CITY WATER SUPPLY, NOT TO WATER PRESSURE TANK.

A - Thermic safety valve

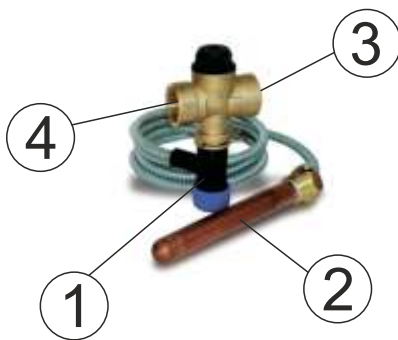

- 1 - thermal protecting valve (must be facing down)
- 2 - thermal protecting valve probe
- 3 - cold water inlet (connect to city water supply)
- 4 - connect to prepared connectors on boiler (C)

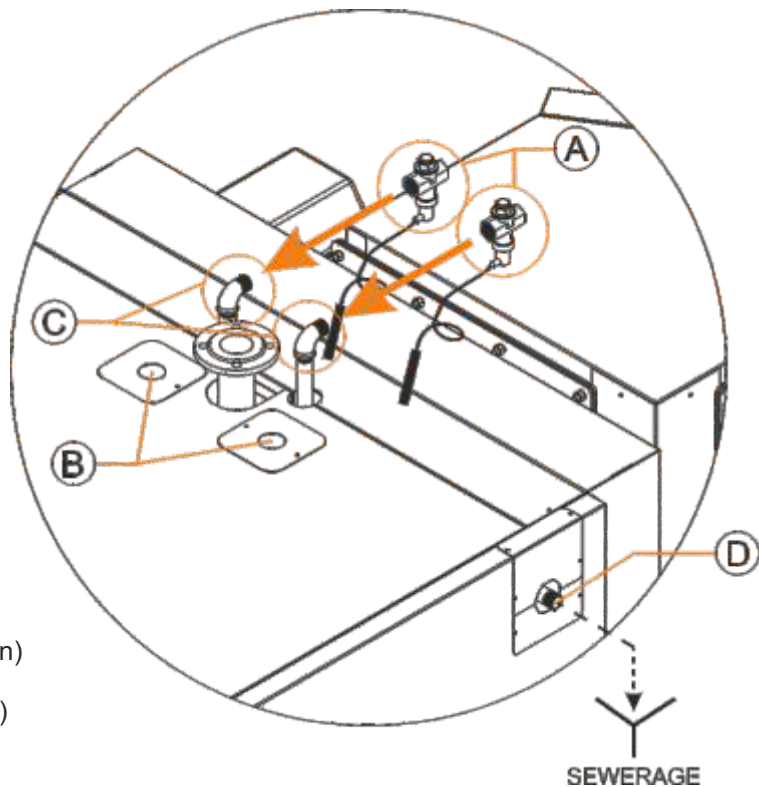

THERMAL FUSE

Thermal fuse for the boiler EKO-CKS Multi Plus is composed from factory in-built heat exchanger and two thermal safety valves (A). Boiler have two prepared connectors (C) for connecting thermal safety valves (A) on in-built heat exchangers. Also, boiler have prepared two connectors (D) (on left and right side of the boiler; on picture are showed just one of them) for exit from factory in-built heat exchanger. Connectors (D) is necessary to connect to sewerage. Thermal safety valve probe (2) must be connected to prepared connector (B).

5.0. CONNECTION OF EARTHING TO BOILER AND EL. ENCLOSURE

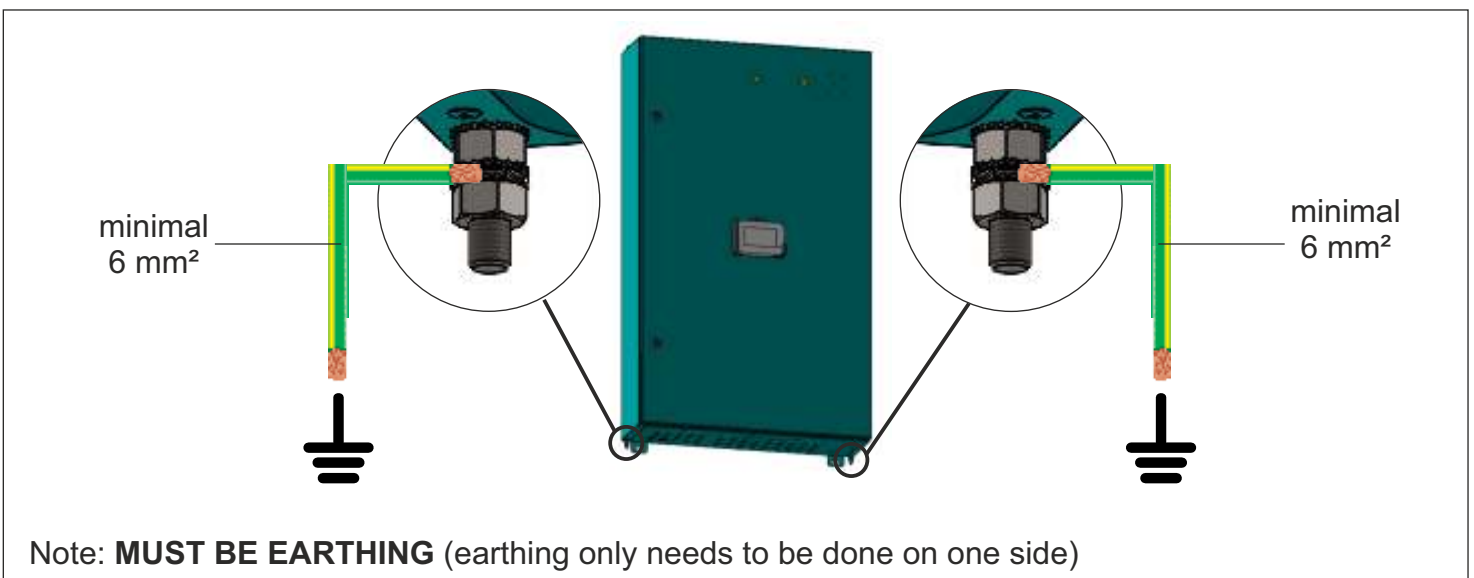
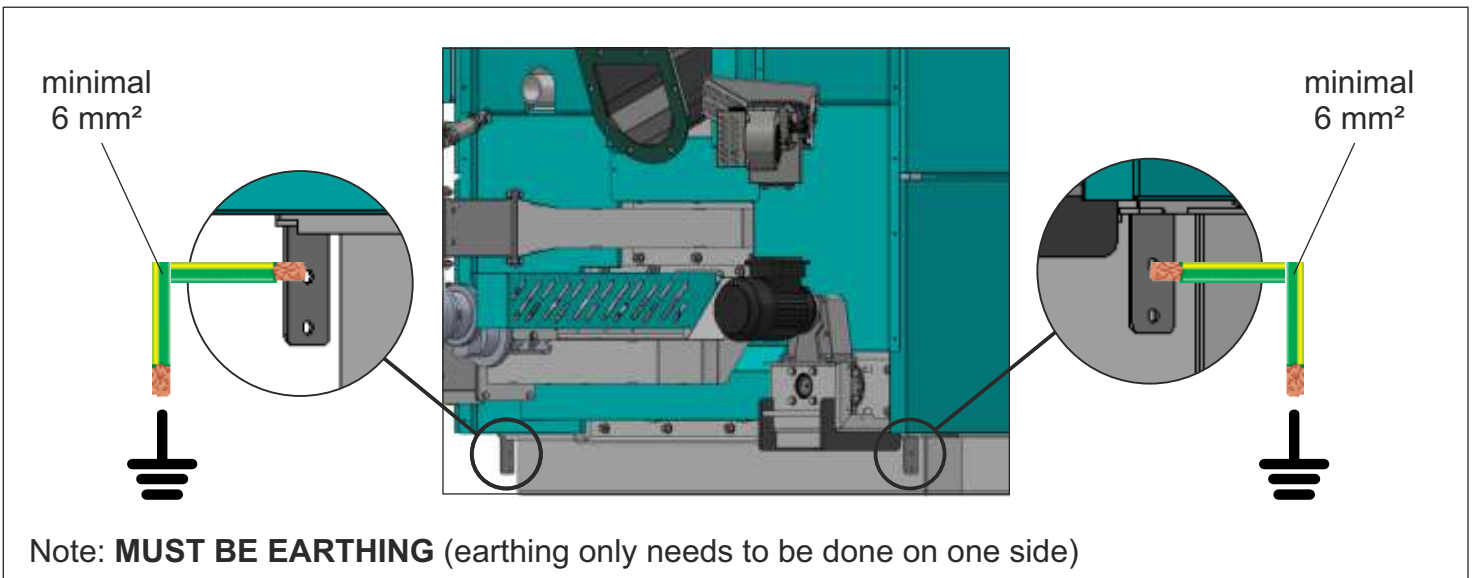
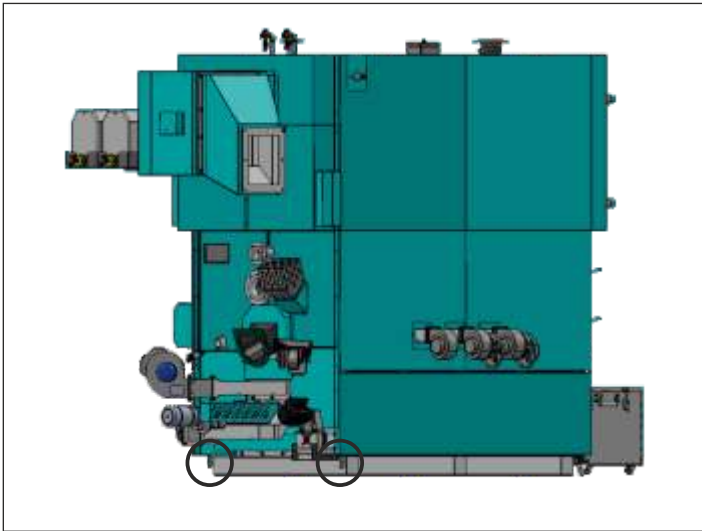

6.0. INSTALLATION OF ADDITIONAL EQUIPMENT

6.1. INSTALLATION OF THE SYSTEM FOR AUTOMATIC EXTRACTION OF ASH FROM THE FLUE GAS CHAMBER (ADDITIONAL EQUIPMENT)

1. Boiler without installed system for automatic extraction of ash from the flue gas chamber.
2. Place flue gas chamber router on side opening. Place shortest side on back side of flue gas chamber, below welded anchors (detail A). Close flue gas opening with lid and fix it with two screws M8x40.

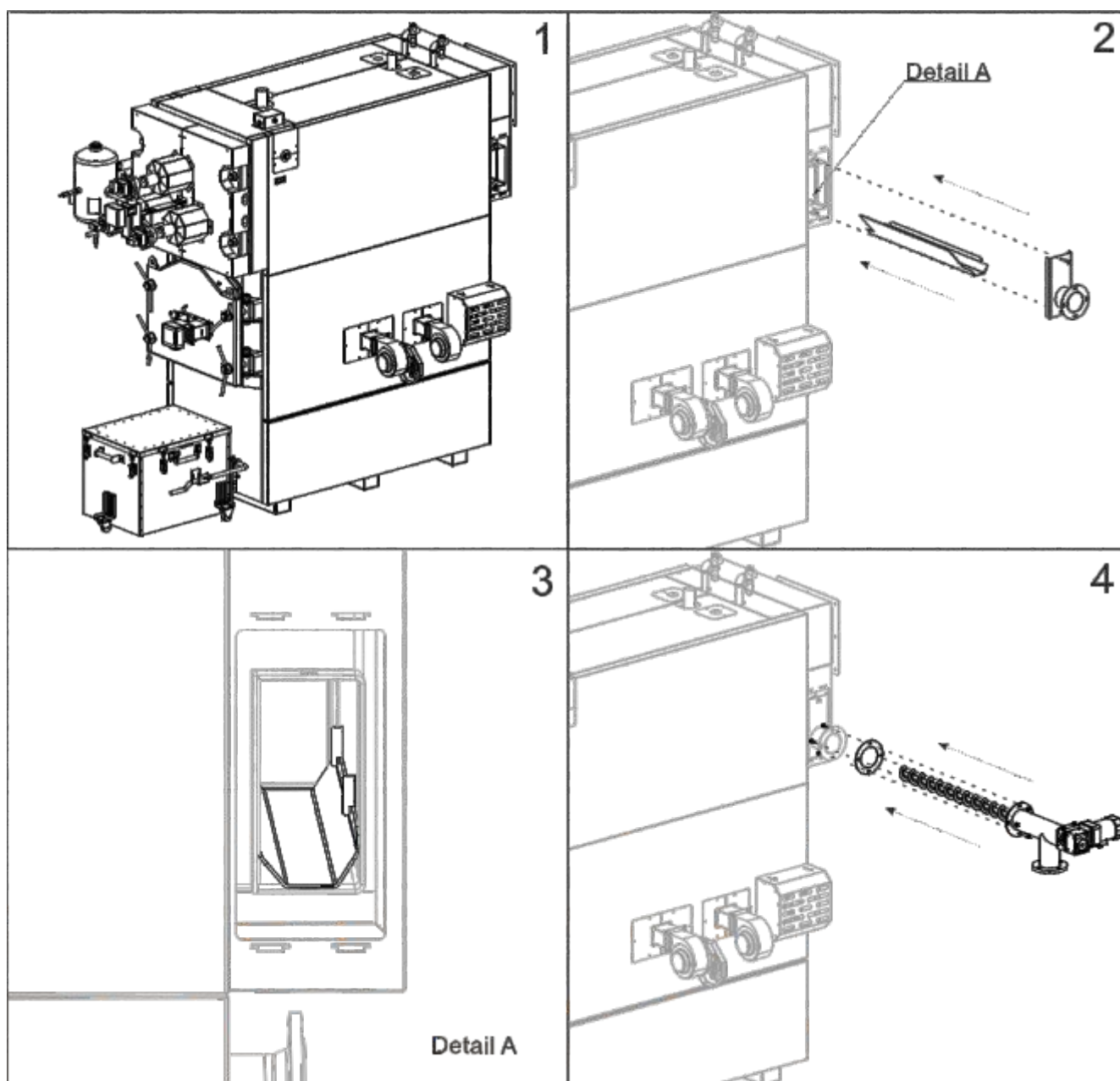

3. Detail A - The channel position is crucial for correct work of ash extraction system.
4. Place conveyor with T-piece and motor device with gearbox through hole on lid. Place gasget between flanges and fix it with four M8 screws and nuts.

5. Place tube with ash box to T-piece (use gasket) and fix it with M8 screws and nuts.
6. Place ash box porter legs on welded U-profile porters and fix it with M10 screws and nuts. Legs allow height adjustment depend about user needs.

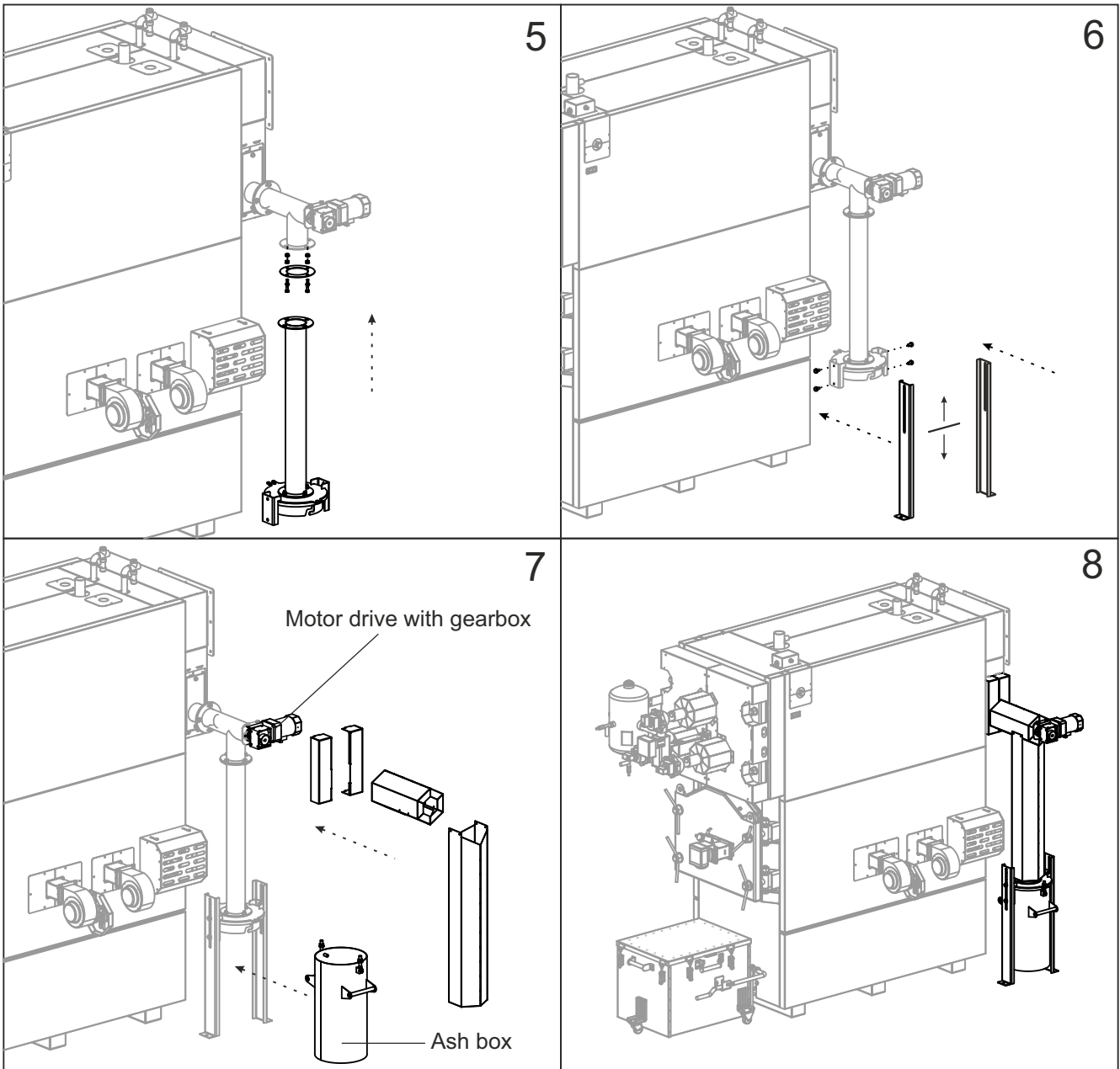

7. Place ash box (volume = 20 liters) and attach it with holders. Delivered mineral wool wrap around conveyor tube. Place casing cover on mineral wool. Casing cover is made that can be bended with hands for shape adjustment. After shape adjustment fix casing cover with screws 3,9x9,5 mm.
8. Assembled system for automatic extraction of ash from the flue gas chamber.
9. System for automatic extraction of ash from the flue gas chamber can be installed in the same way symmetrically on the opposite side of the boiler depending on where it more closely corresponds with the the actual state of the boile room.

6.2. INSTALLATION OF THE SYSTEM FOR AUTOMATIC EXTRACTION OF ASH FROM THE FLUE GAS CHAMBER (ADDITIONAL EQUIPMENT)

Figure 9. Automatic pneumatic air cleaning of boiler flue passages

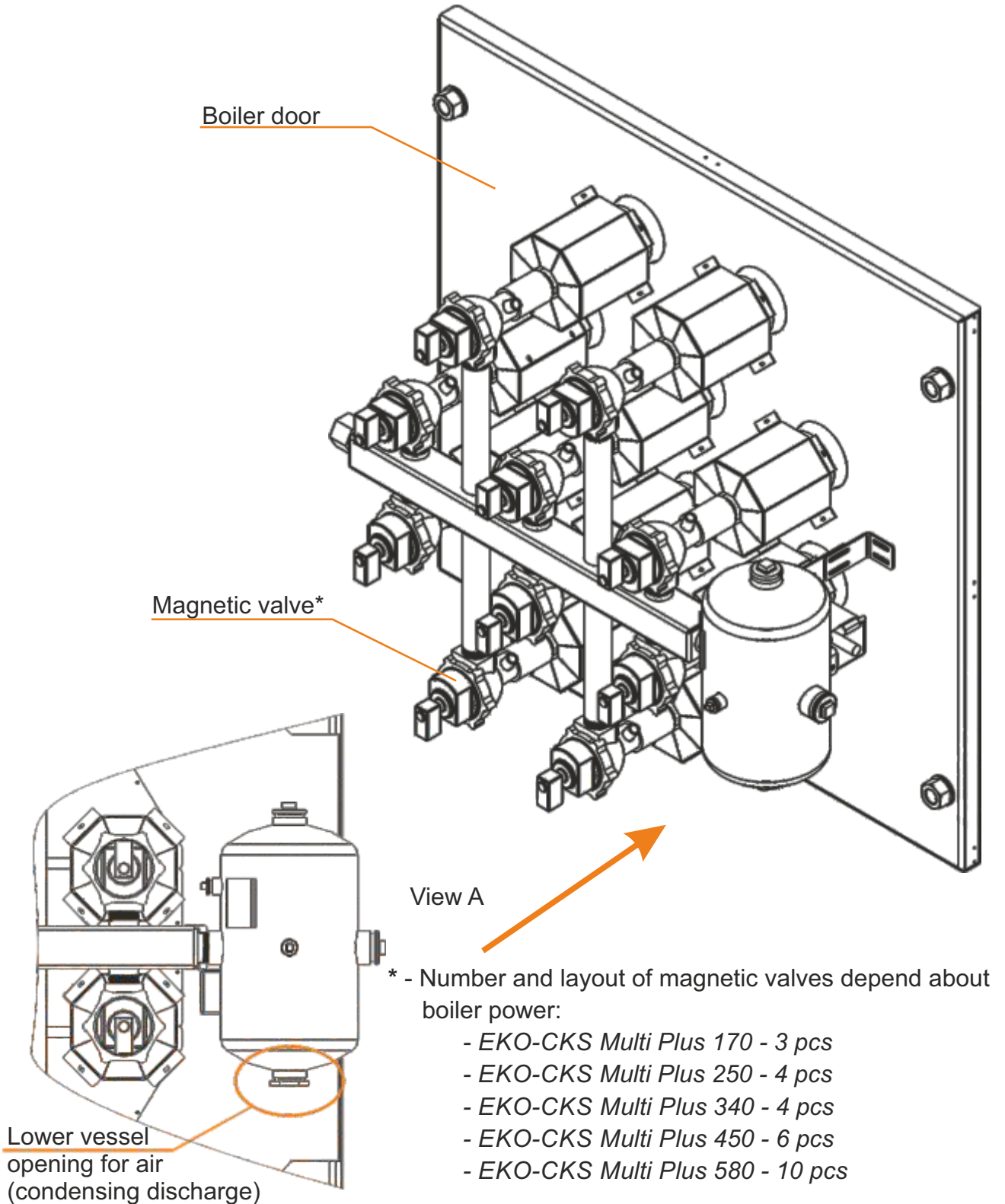

6.2.1. PNEUMAT INSTALLING

Delivery status

Delivery is consist from:

- compressor with installed additional parts
- PU pipes Ø10mm (5 m)



Compressor

Compressor is delivered with installed:

- fast coupling
- ball valve 1/4"
- pressure switch
- dirt trap
- electromagnetic valve

Compressor set connection

It's necessary to connect compressor and pressure vessel which is mounted on boiler door. Connection is performing by using polyurethane pipe (PU) which is connect on fast couplings installed on vessel and compressor. Fast couplings enable easy and safe connection. At connection just press pipe to fast coupling. For decoupling press plastic ring inward and then pull pipe from coupling (figure 1). After connecting pressure line compressor must be plug to electrical installation.

Figure 1.

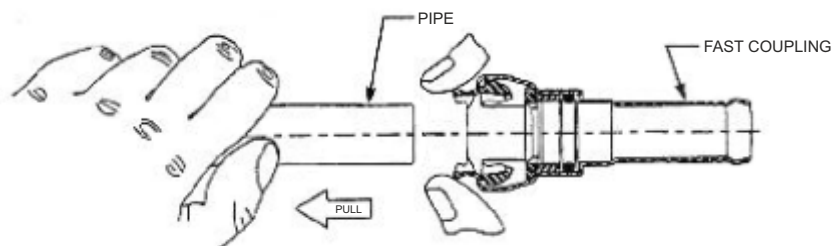

Air cleaning is intended for flue gas tube cleaning by using compressed air. System for air cleaning must be always connected to air compressor (as shown on figure) or to compressed air installation if is exist. Air pressure from air compressor or compressed air installation **must be** adjusted to **5 bar**. Air cleaning system work is managed by boiler control unit. Working parameters are adjusted with boiler first start-up. If necessary, drain the condensate from the air compressor on the air cleaning system. Condensate is discharged at the lower opening of the air compressor.

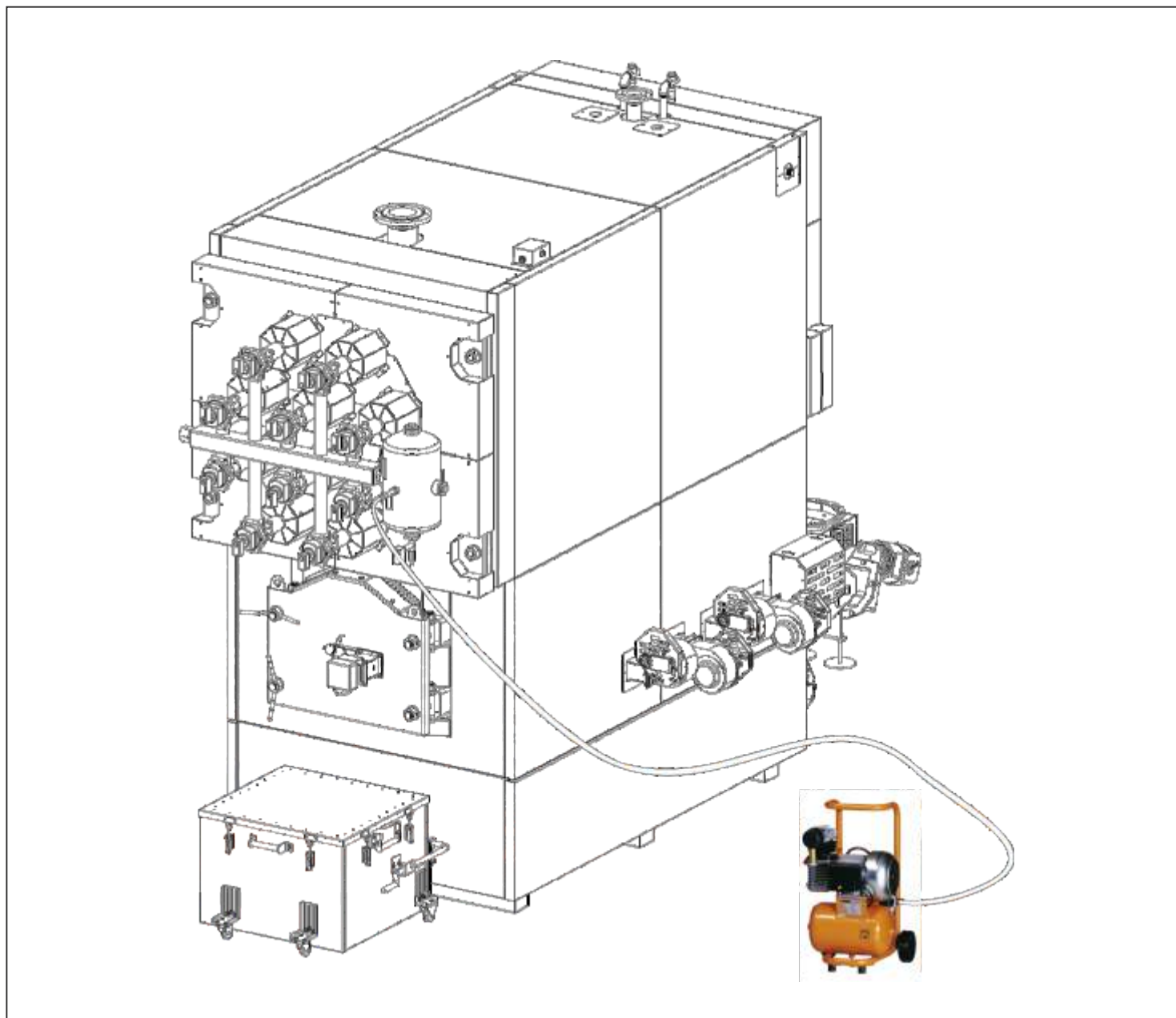

CONDENSATE DRAINAGE

PERIOD: Automatic.

Air compressor produce condensated water which was accumulated in air vessel. Condensated water must be drained. Drainage is performed by electromagnetic valve which are placed below air compressor vessel and compressed air vessel on boiler door (see Figure 1). Electromagnetic valves are managed by boiler control unit.

Figure 1.

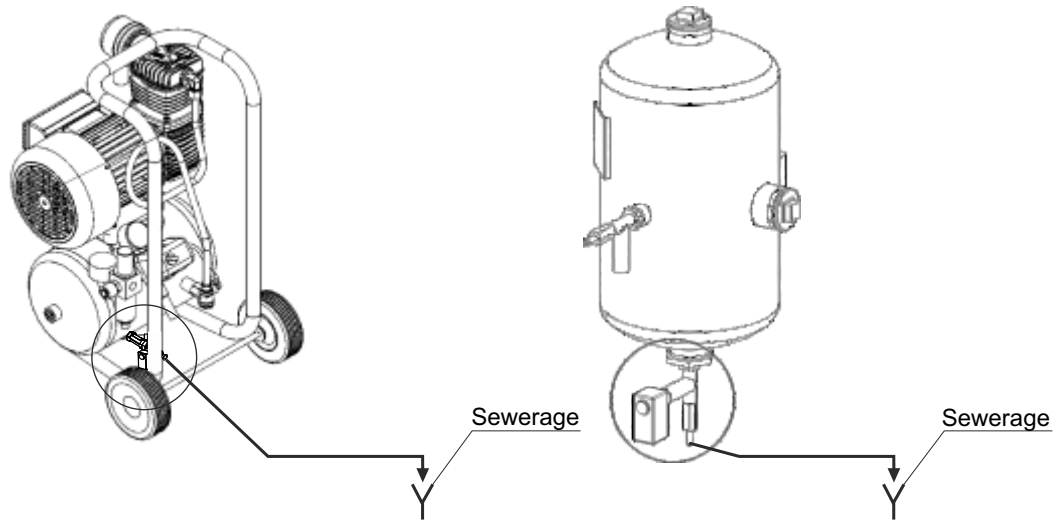

OIL LEVEL CHECKING

PERIOD: Every two days.

Compressor have enough oil if sight gauge show 2/3 of oil (see Figure 2.).

For refilling is allowed to use only sintetic oil 5W50.

Figure 2.

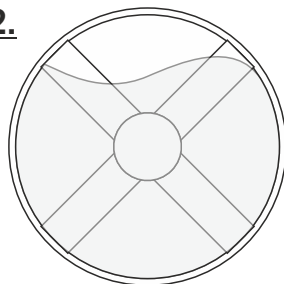

6.2.2. ELECTRICAL SCHEME

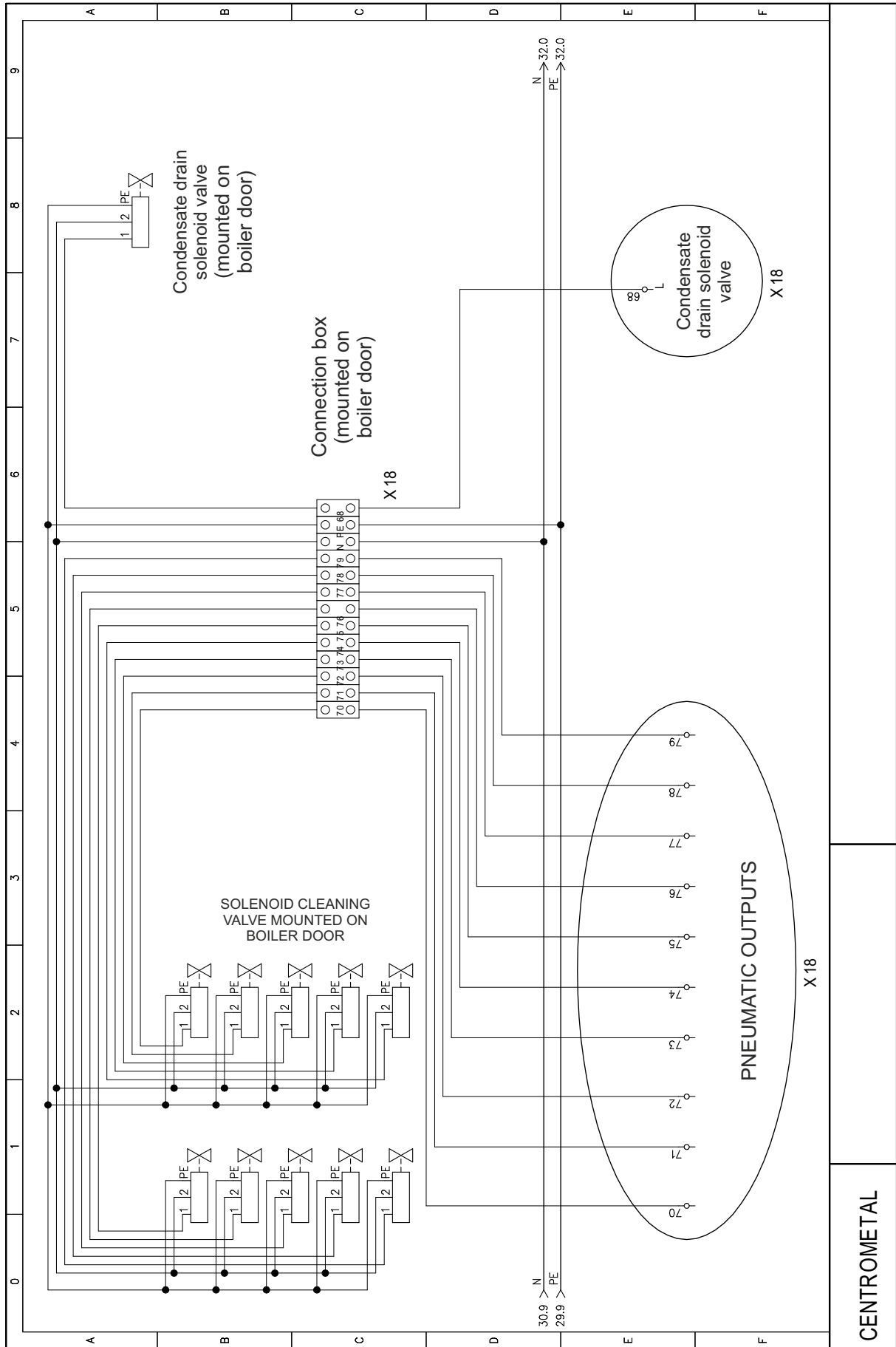

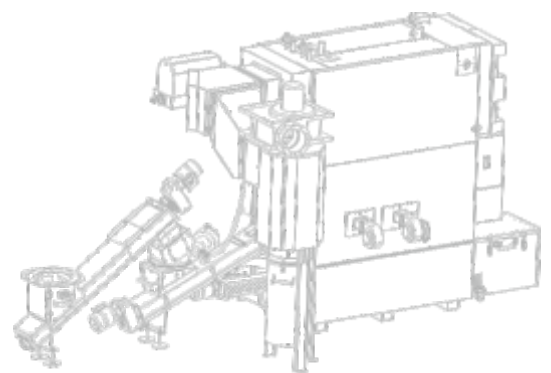

Centrometal d.o.o. shall not be responsible for possible incorrect data caused by printing errors or error made in transcription and all figures and diagrams are for explanatory purposes only and relevant adjustment have to be made at the spot. In any case, it reserves the right to modify its products as deemed to be required and useful without any prior notification.

Centrometal d.o.o. Glavna 12, 40306 Macinec, Croatia

central tel: +385 40 372 600, fax: +385 40 372 611
service tel: +385 40 372 622, fax: +385 40 372 621

www.centrometal.hr
e-mail: servis@centrometal.hr

Centrometal
HEATING TECHNIQUE