

Centrometal

HEATING TECHNIQUE

Centrometal d.o.o. - Glavna 12, 40306 Macinec, Croatia, tel: +385 40 372 600, fax: +385 40 372 611

TECHNICAL INSTRUCTIONS



for installation, use and maintenance
of hot water boiler
and installation of additional equipment

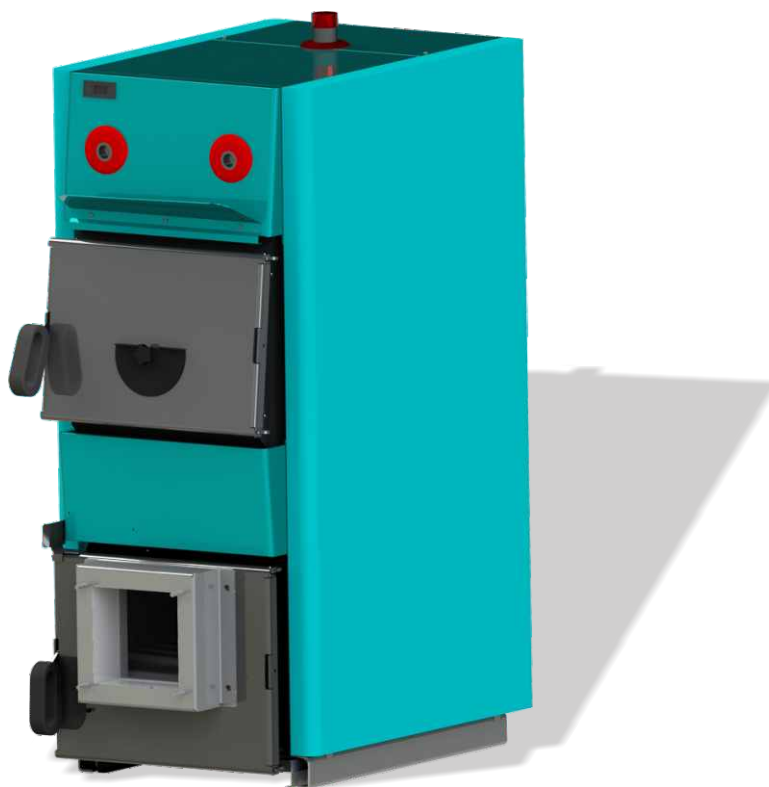

EKO-CK P

TECHNICAL DATA

TYPE		EKO-CKP 20	EKO-CKP 25	EKO-CKP 30	EKO-CKP 35	EKO-CKP 40	EKO-CKP 50	EKO-CKP 60	
Nominal heat output	(kW)	14	20	25	30	35	40	50	
Heat output range	(kW)	4,2-14	6-20	7,5-25	9-30	10,5-35	12-40	15-50	
Boiler class		5							
Required chimney underpressure	(Pa)	11	12	13	14	15	20	22	
Water amount in boiler	(lit.)	60	64	67	76	78	96	118	
Exhaust gas temperature at nominal heat output	(°C)	170	170	170	170	170	180	180	
Exhaust gas temperature at minimum heat output	(°C)	80	80	80	80	80	80	80	
Exhaust mass flow at nominal heat output	(kg/s)	0,011	0,015	0,018	0,023	0,027	0,031	0,034	
Exhaust mass flow at minimum heat output	(kg/s)	-	-	-	-	-	-	-	
Standby heat losses	(kW)	0,294	0,42	0,368	0,63	0,735	0,84	0,596	
Boiler resistance on water side at nominal output	(mbar)	7	9	10	11	13	18	25	
Fuel type		wood pellets							
Maximum heat input	(kW)	15,6	22,2	27,8	33,33	38,88	44,44	55,55	
Fuel moisture content	(%)	max.12							
Fuel size	(mm)	φ 6 x max.50							
Firebox volume /tank volume	(l)	75,4/330	80/330	92,5/330	105/330	116/330	161/330	167/330	
Combustion chamber dimensions	(mm)	321x506x550	321x541x550	371x541x550	421x541x550	471x541x550	471x664x550	471x664x650	
Combustion chamber volume	(l)	89,3	95,5	110,3	125,2	140	172	203,2	
Combustion chamber type		overpressure							
Required minimum accumulation next to boiler	(lit./kW)	by EN 303-5 point 4.2.5							
Electrical power input	(W)	250							
Supply voltage	(V~)	230							
Frequency	(Hz)	50							
Current type		~							
Boiler dimensions with casing	Lenght (A)	(mm)	985	1020	1020	1020	1020	1142	1142
	Width (B)	(mm)	470	470	520	570	620	620	620
	Height (C)	(mm)	1255	1255	1255	1255	1255	1255	1355
Boiler body mass	(kg)	203	210	230	241	267	310	327	
Total mass - (boiler with casing and accessories)	(kg)	227	234	255	266	293	337	355	
Max. operating overpressure	(bar)	2,5							
Test pressure	(bar)	5,5							
Max. operating temperature	(°C)	90							
Uptake tube - external diameter	(mm)	150	150	160	160	180	180	180	
Boiler connections	Flow and return pipe (male thread)	(R)	5/4"						
	Charge/discharge (female thread)	(R)	1/2"						
	Heat exchanger connector (female thread)	(R)	1"						
	Connector of exchanger sensor (female thread)	(R)	1/2"						
Number of turbulators	(pcs)	3	3	4	4	5	5	5	

Total system dimensions	EKO-CK P 20	EKO-CK P 25	EKO-CK P 30	EKO-CK P 35	EKO-CK P 40	EKO-CK P 50	EKO-CK P 60
Total length (D) (mm)	1280	1280	1280	1280	1280	1440	1440
Total width (E) (mm)	1095	1095	1145	1195	1245	1245	1245
Total height (F) (mm)	1545	1545	1545	1545	1545	1545	1545
Uptake tube height (G) (mm)	930	930	930	930	930	1025	1025

The boiler EKO-CK P with equipment for wood pellets firing (Cm Pelet-set)

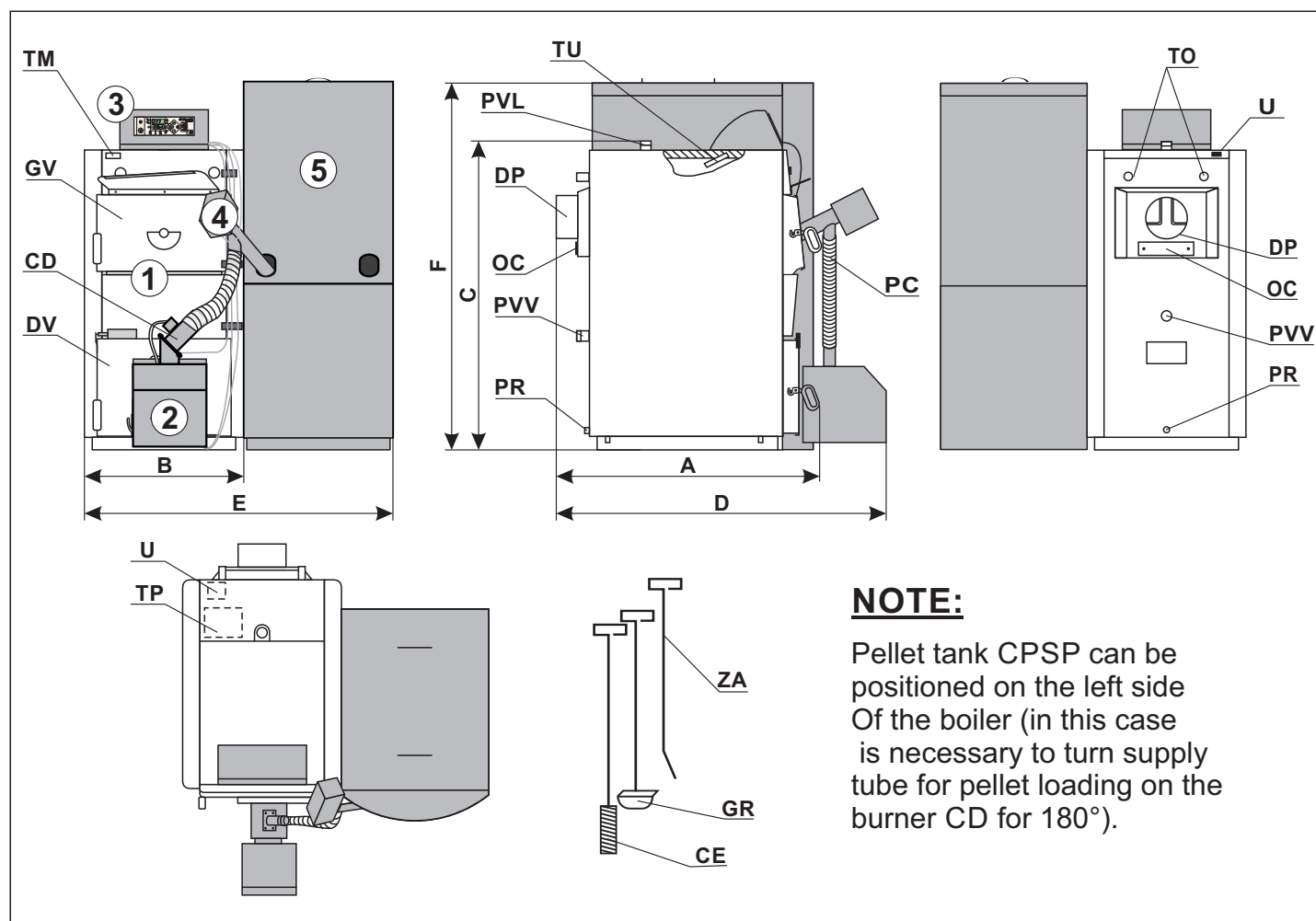

NOTE:

Pellet tank CPSP can be positioned on the left side of the boiler (in this case is necessary to turn supply tube for pellet loading on the burner CD for 180°).

LEGENDE:

① - Boiler EKO-CK P

Cm Pelet-set:

② - Pellet burner CPPL

③ - Pellet control unit CPREG

④ - Pellet tank CPSP

⑤ - Feeder screw CPPT

DV - Lower boiler door

GV - Upper boiler door

TM - Thermometer

PRA - Filling / drainage

PVV - Outlet line

OC - Cleaning opening

DP - Chimney connection

PVL - Inlet line

TU - Sensor sleeve

PC - Plastic flexible pipe

U - Socket of the pump thermostat

TO - Thermal protection connectors (not used on boiler with installed Cm Pelet-set)

TP - Pump thermostat

ZA - Poker

GR - Scraper

CE - Cleaning brush

CD - Supply tube for pellet loading

1.0. GENERAL

The boiler **EKO-CK P** has a modern construction and design and is made out of the controlled materials of high quality, welded with most modern technology and is approved and tested under EN 303 - 5 norm and fulfil all special request for the connection on the installation of a central heating system.

1.1. BOILER DESCRIPTION

The boiler **EKO-CK P** is steel hot water boiler. The combustion chamber has a large heating surface and low combustion chamber resistance. Boiler cleaning is very simple and it is possible to clean it from the front side.

1.2. DELIVERY STATE

The boiler with boiler door is delivered on a wooden pallet, with turbulators in combustion chamber, cleaning accessories (poker, scraper and holder for cleaning accessories) and set (sheet metal screws, screws and plug).

1.3. OBLIGATORY ADDITIONAL EQUIPMENT OF THE BOILER EKO-CK P FOR WOODEN PELLETS FIRING

1. For boilers: **EKO-CK P 20**

- pellet burner CPPL-14 digital boiler control unit CPREG for pellet burner CPPL-14
- pellet tank CPSP
- pellet feeder CPPT

2. For boilers: **EKO-CK P 25, EKO-CK P 30, EKO-CK P 35 and EKO-CK P 40**

- pellet burner CPPL-35, digital boiler control unit CPREG for pellet burner CPPL-35
- pellet tank CPSP
- pellet feeder CPPT

3. For boilers: **EKO-CK P 50 and EKO-CK P 60**

- pellet burner CPPL-50, digital boiler control unit CPREG for pellet burner CPPL-50
- pellet tank CPSP
- pellet feeder CPPT-50

2.0. BOILER POSITIONING AND ASSEMBLY

Boiler positioning and assembly and building in must be performed by a qualified person. We recommend that boiler is placed on a concrete base having height of 50 to 100 mm above the floor. Boiler room must be frost-proof and well ventilated. Boiler has to be positioned so that it can be properly connected to the chimney (see point 4.0) and simultaneously, enabling tending of boiler and additional equipment, control during operation, and cleaning and maintenance (see Figure 1).

WARNING!

Flammable items must not be placed on the boiler and within the safety distances shown in Figure 1.

Figure 1. Minimum distance from the room walls

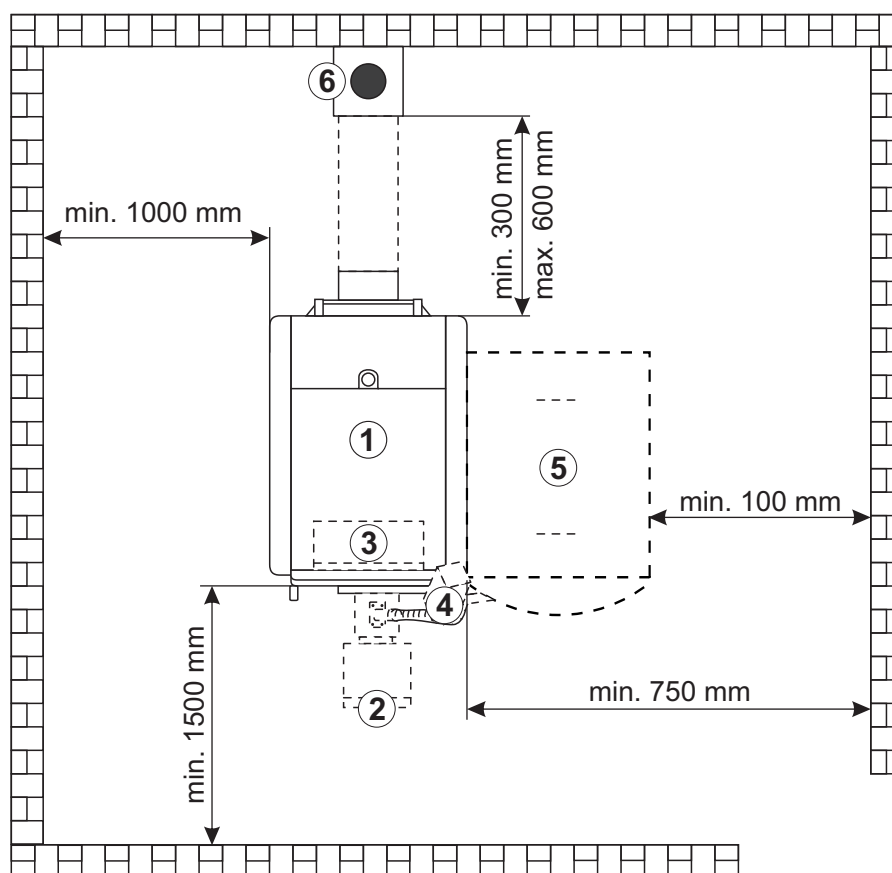

Legend:

- | | | |
|------------------------|-------------------------------|----------------------|
| ① - Boiler EKO-CK P | ③ - Pellet control unit CPREG | ⑤ - Pellet tank CPSP |
| ② - Pellet burner CPPL | ④ - Pellet feeder CPPT | ⑥ - Chimney |

2.1 CHANGING OF DOOR OPENING DIRECTION

Upper and lower boiler door are factory designed so that it can be changed opening direction to left or right side. Opening direction can be changed. It is necessary to change positions of universally parts responsible for direction of door opening. Universally parts are shown in figure 4. Handle, hinge and handle latch holder are universally parts which hold upper and lower boiler door. Lower boiler door have one additional piece (microswitch breaker) which position must be changed. Door are default mounted to open on right side. On page 7 are shown how to change direction of door opening on left side.

Procedure are same for upper and lower boiler door except microswitch on lower boiler door.

Figure 2.

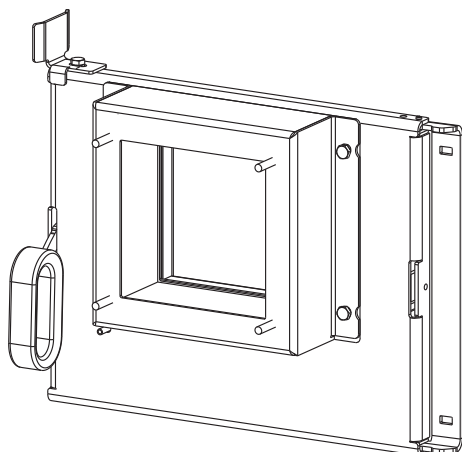

Lower boiler door which opens to the right side (default).

Figure 3.

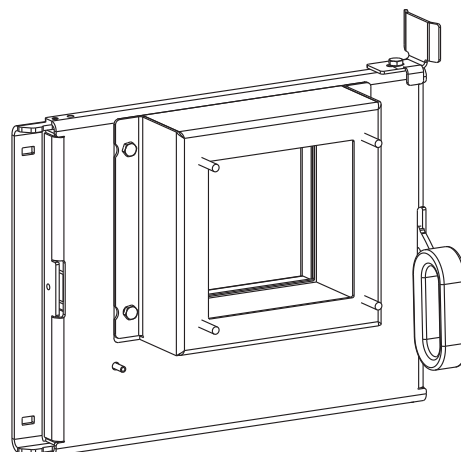

Lower boiler door readjusted for opens to the left side.

Figure 4. Universally door parts needed to install on opposite side to change the door opening direction



- ① Handle
- ② Hinge
- ③ Handle latch holder (on the boiler)
- * ④ Microswitch breaker

* Only on lower boiler door.

The process of converting factory delivered lower boiler door with right opening direction (default) to door with left opening direction.

1. Removing door from boiler and remove universally parts from door

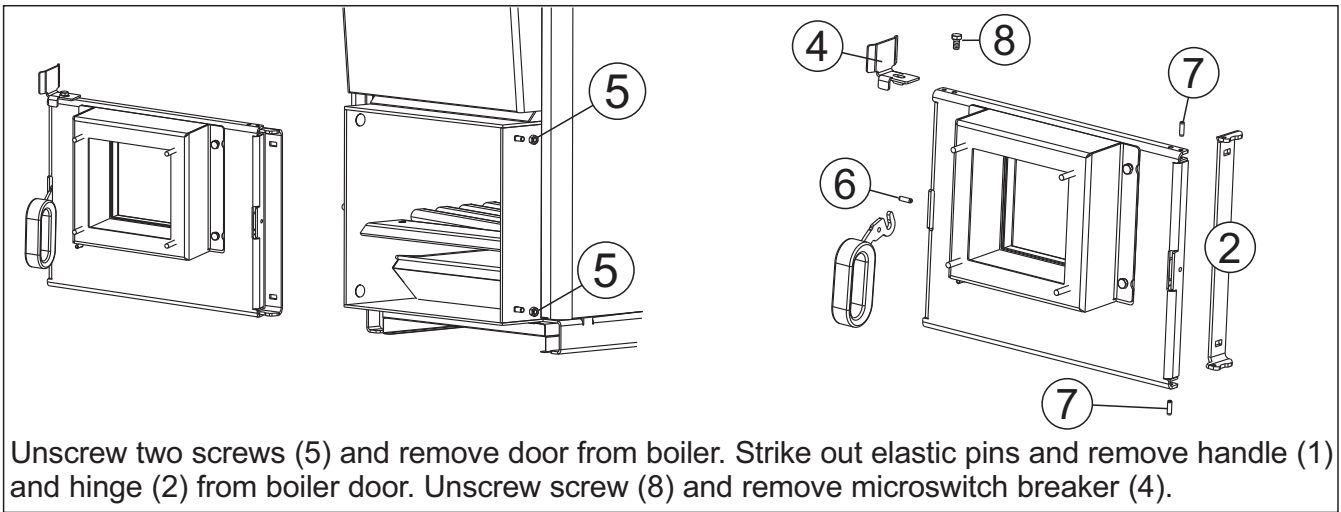

2. Installing universally parts to the other side

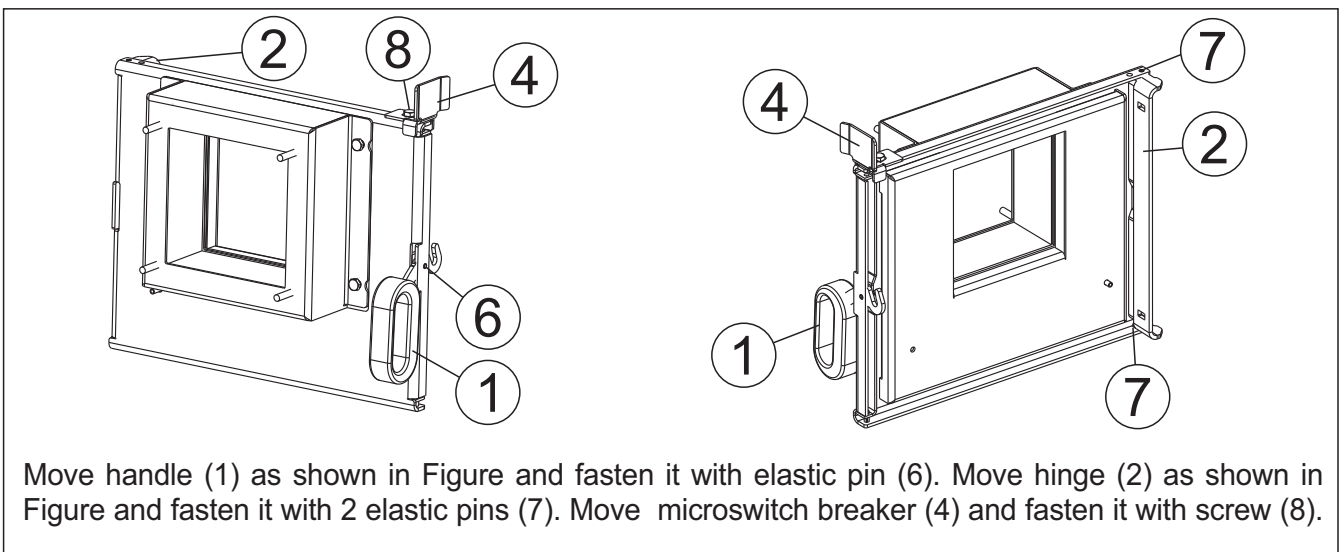

3. Installing of handle latch holder and door to boiler

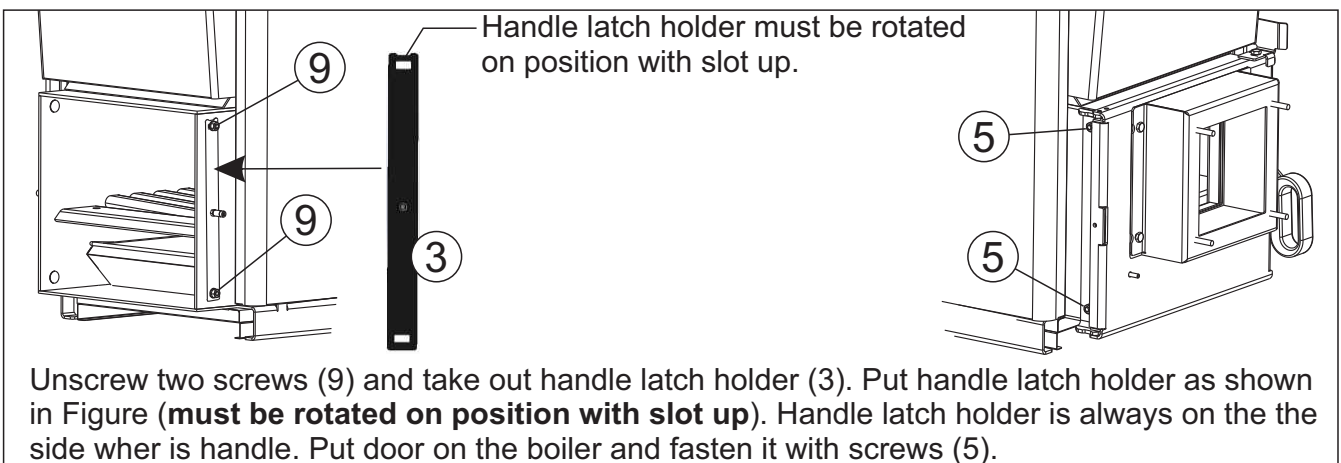
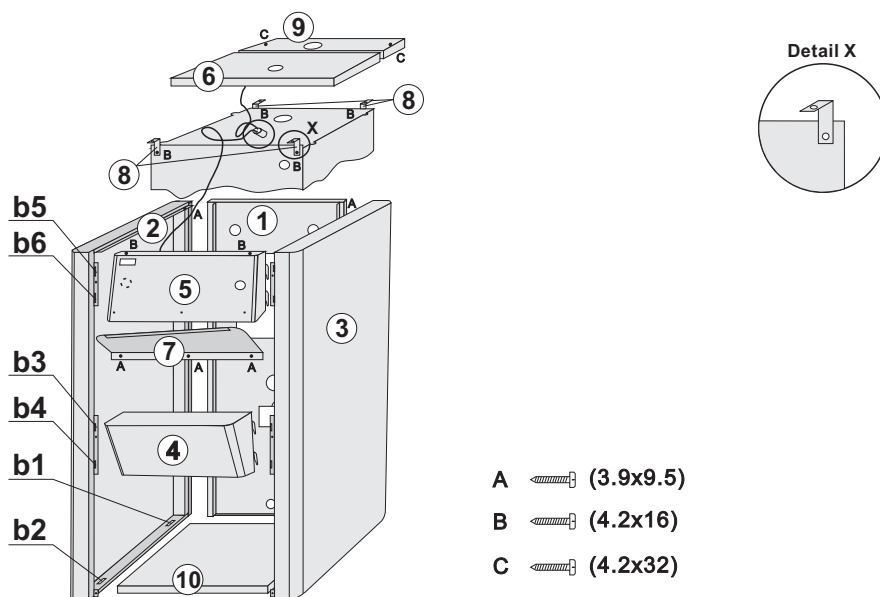

Figure 5. Installation of casing to boiler EKO - CK P



1. Fasten insulation support (8) with screws 4,2 x 16 into wholes at the upper side of the boiler body.
2. Fix the lateral sides (2) and (3) on girders on the lateral sides of the boiler mount into rectangular opening of the casing lateral sides (b1) and (b2), hook them up on casing supports (8), and fix them with two screws on sheet metal 3.9 x 9,5 on the rear casing supports (8).
3. The front upper casing side (5) has to be hooked up with hooks into rectangular openings of the lateral left and lateral right side of the casing (b5) and (b6), and fixed with one screw on sheet metal 4,2 x 16 into the front casing support (8) through the lateral side (2) and with one screw for sheet metal 4,2x16 into the front casing support (8) through the lateral side (3).
4. The front bottom casing side (4) has to be hooked up with hooks into rectangular openings of casing lateral sides (b3) and (b4).
5. We insert the thermometer sensor at the front upper side of the casing (5) and pump thermostat sensor at the rear casing cover (9) into the probe at the upper side of the boiler, and secure the sensors with wire delimiter supplied in the set (Detail Y).
6. We position the front casing cover (6) on the groove of the front upper casing side, and the rear casing cover (9) on the groove of the front casing cover (6).
7. We hook the rear casing side (1) on the connecting pipe and fix it with 2 screws for sheet metal 4,2 x 32 on the lateral side (2) and 2 screws for sheet metal 4,2 x 32 on the lateral side (3).
8. We fix the rear casing cover (6) from the upper side with 2 screws for the sheet metal 4,2 x 32 on lateral casing sides (2) and (3).
9. At the end, we fix the draught regulator protection (7) on the front upper casing side (5) on the prefabricated holes with three sheet metal screws 3,9 x 9,5.
10. Finally, we take the base protection (10) and insert it under the boiler between the supports holding the boiler.

3.0. OPENING FOR FRESH AIR (FRESH AIR SUPPLY)

Each boiler room **must be equipped with an opening** for supply of fresh air which is dimensioned in accordance with boiler output (minimum opening area according to the below shown equation). Such opening must be protected with a net or grate. All installation works have to be performed in accordance with valid national and European standards. Boiler must not operate in flammable and explosive environment.

$$A = 6,02 \cdot Q$$

A - opening area in cm²
Q - boiler output in kW

4.0. CONNECTION TO CHIMNEY

Properly dimensioned and built chimney is a precondition for safe boiler operation and heating efficiency. A chimney must be thermally insulated, gas-tight and smooth. Cleaning door must be made in the lower part of a chimney. Chimney made of bricks must include 3 layers with central insulation layer made of mineral wool. Thickness of thermal insulation should be min. 30 mm of chimneys is built against to interior wall, and min. 50 mm if it is built on the outer side. **Internal dimensions of the chimney light diameter depend on chimney height and boiler output and they have to be selected in accordance with diagram shown in Figure 3.** The chimney usable height is the measure from connection spot of smoke pipe to the chimney top. As these boilers can be fired with wooden pellets at any time, chimney has to be selected according to the wooden pellets diagram. Fuel gas temperature at the chimney exist must be min. 30°C higher than condensation temperature of combustion gases. Selection and building of a chimney must be made by a professional. Required maximum distance from boiler to chimney is 600 mm, and minimum distance is 300 mm. Uptake tube must be installed at an angle (min. 5°) with a gradient from chimney to boiler (Figure 2). In order to prevent condensate from chimney to enter the boiler, uptake tube must be placed 10 mm deeper into chimney. Connecting uptake tube between boiler and chimney **must be thermally insulated** with a mineral wool layer having thickness of 30 to 50 mm.

All installation works must be made in accordance with valid national and European standards.

Figure 2. Possible ways of connections of boilers **EKO-CK P** to chimney

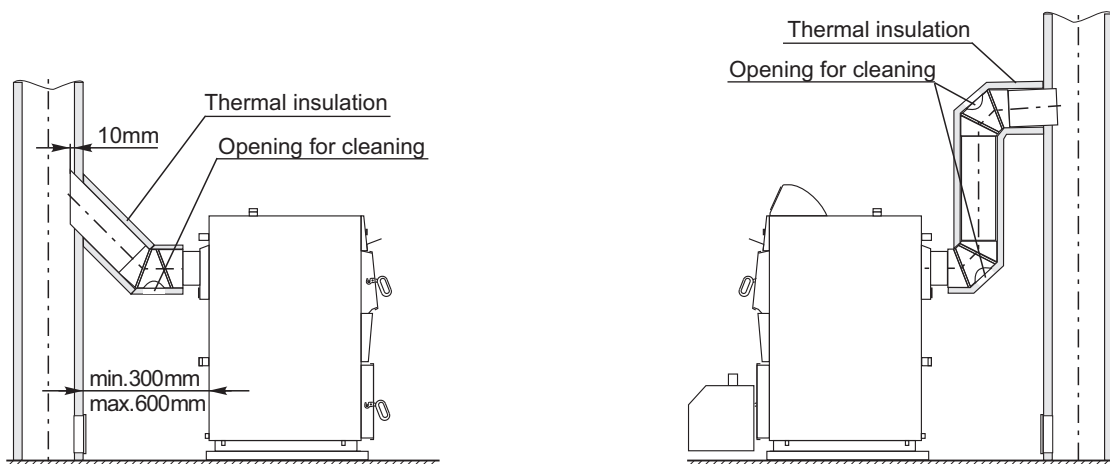

Possible way of connection of boilers **EKO-CK P** to chimney **(recommendation)**

Possible way of connection of boilers **EKO-CK P** with pellet burner to chimney

Figure 3. Chimney dimensioning for boilers **EKO-CK P**

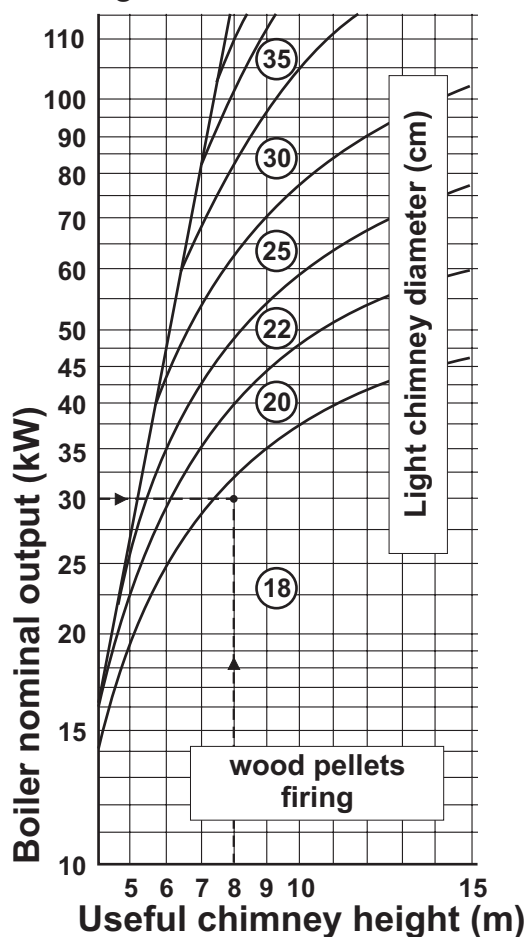

4.1. AN EXAMPLE OF SELECTION OF A CHIMNEY (see diagram on Figure 3.)

- BOILER HEAT OUTPUT - 30 kW
- FUEL - WOOD PELLETS
- REQUIRED USABLE CHIMNEY HEIGHT - $H = 8$ m
- REQUIRED CHIMNEY LIGHT DIAMETER - 18 cm

- **Usable chimney height** - chimney height from connection spot of smoke pipe to the chimney top.
- **Light chimney diameter** - interior chimney diameter.

5.0. BOILER INSTALLATION TO CENTRAL HEATING SYSTEM

All installation works must be made in accordance with valid national and European standards. Boiler EKO-CK P can be built to closed and open central heating systems. In both cases boiler can be fired with wooden pellets. Installation has to be made, in according to technical standards, by a professional who will be responsible for proper boiler operation. Before connecting boiler to central heating system, the system has to be flushed to remove impurities remaining after system installation. It prevents boiler overheating, noise within the system, disturbances at a pump and mixing valve. Boiler should always be connected to central heating system by connectors, never by welding. Figure 1. shows safe distances required for boiler cleaning and maintenance.

5.1. BOILER INSTALLATION TO CLOSED HEATING SYSTEM

In closed heating system (as in example shown in Scheme 1a and 1b) it is **obligatory** to build in certified safety valve with opening pressure of 2,5 bar, minimum seat diameter of 15 mm, minimum inlet connection of 1/2", minimum exit connection of 3/4" and a membrane expansion vessel. Safety valve and expansion vessel must be built in accordance with professional rules and any valve must not be located between safety valve and expansion vessel and boiler. In all boiler types the heating pump **must be** connected to boiler control unit CPREG (see Technical instructions for the commissioning and adjustment of Cm Pelet-set for boilers EKO-CK P and EKO-CKB P). If boiler is connected to the heating system under Diagram 1b., it is recommended that the environment temperature control is made by a 4-ways manual mixing valve.

Installation of boiler EKO-CK P to closed heating system

Scheme 1a. An example of building in of accumulation tank into the central heating system required under EN 303-5

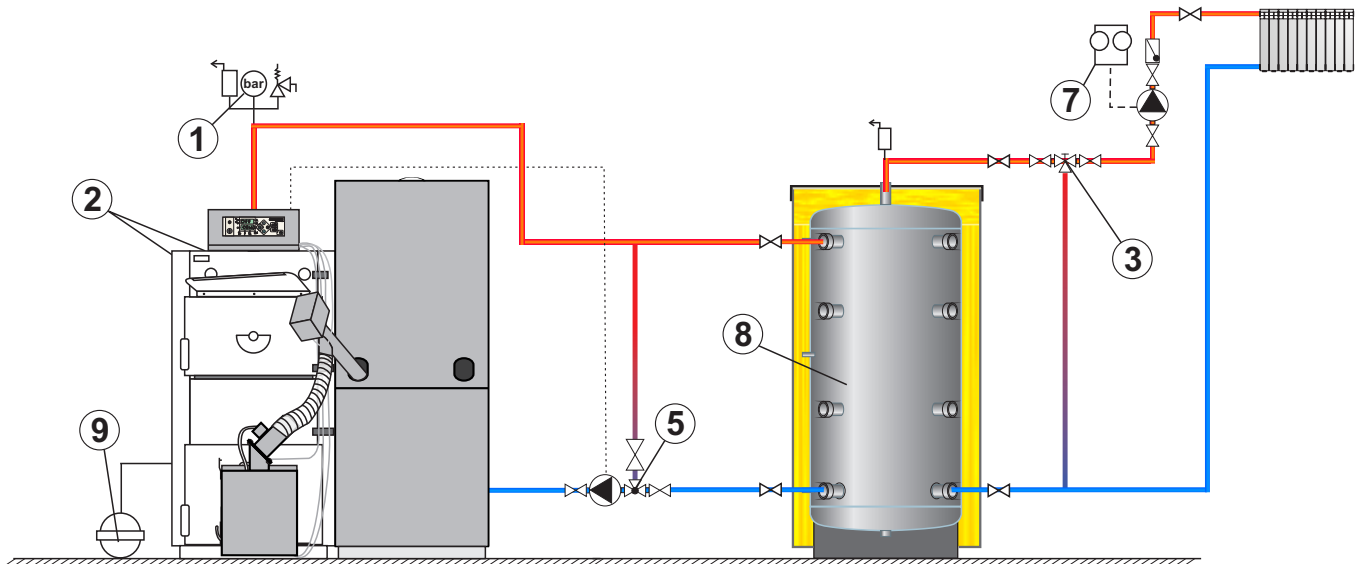

Scheme 1b. An example of building in of accumulation tank into the central heating system not required under EN 303-5

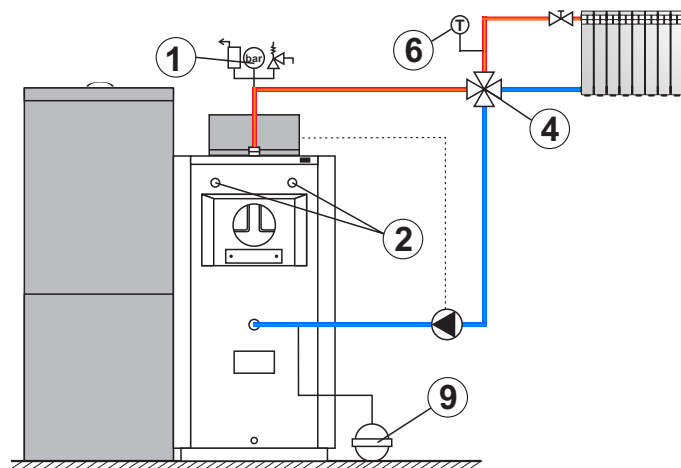

- ①-Obligatory installation of air self-venting group (safety valve 2,5 bar)
- ②-Close tightly
- ③-Manual 3-ways mixing valve
- ④-Manual 4-ways mixing valve
- ⑤-Thermostat valve-Temperature of return line min. 60°C
- ⑥-Thermometer
- ⑦-Room thermostat
- ⑧-Accumulation tank (CAS)
- ⑨-Closed-type expansion vessel

5.2. BOILER INSTALLATION TO OPEN HEATING SYSTEM

If boiler is installed in an open central heating system, it is recommended that system is made according to Scheme 2a or 2b. In open system it is necessary to put an open expansion vessel above the height of the highest heating body. If expansion vessel is located in a room without heating, it should be insulated. The system pump could be connected on the inline or back line of the boiler. The heating pump **must be** connected to boiler control unit CPREG (see Technical instructions for the commissioning and adjustment of Cm Pelet-set for boilers EKO-CK P and EKO-CKB P). If boiler is connected to the heating system under Diagram 2b., it is recommended that the environment temperature control is made by a 4-ways manual mixing valve.

Example of installation of boiler EKO-CK P in an open heating system

Scheme 2a. An example when building in of accumulation tank into the central heating system required under EN 303-5

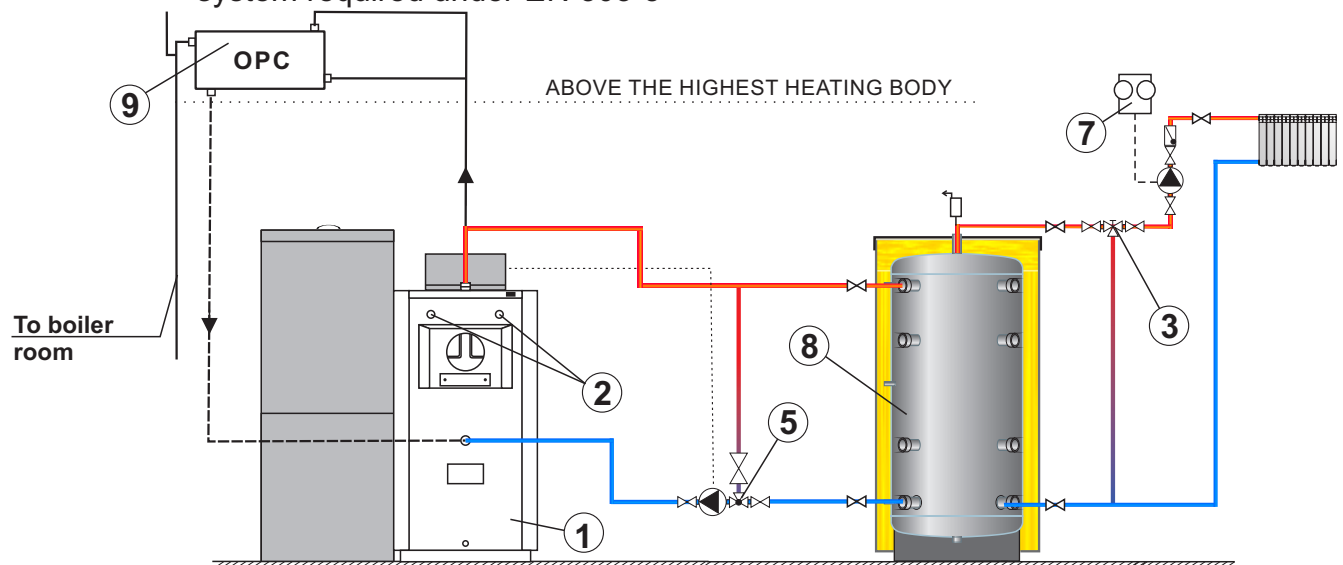

Scheme 2b. An example when building in of accumulation tank into the central heating system is not required under EN 303-5-5

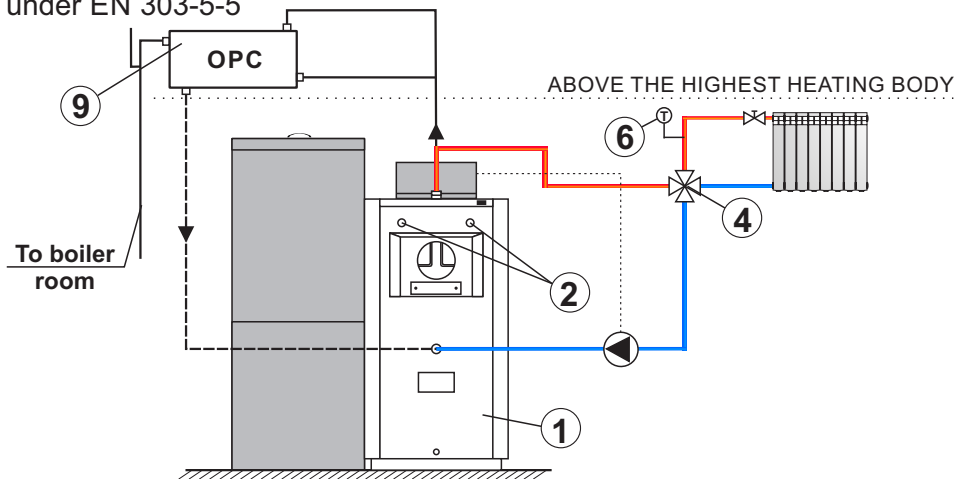

- | | |
|--|------------------------------|
| ① -boiler EKO-CK P | ⑥ -thermometer |
| ② -close tightly | ⑦ -room thermostat |
| ③ -manual 3-ways mixing valve | ⑧ -accumulation tank (CAS) |
| ④ -manual 4-ways mixing valve | ⑨ -open expansion vessel OPC |
| ⑤ -thermostat valve-ensures temperature in return pipe min. 60°C | |

6.0. MOUNTING OF OBLIGATORY ADDITIONAL EQUIPMENT WOODEN PELLETS FIRING

For each boiler EKO-CK P intended for wooden pellets firing need to be **further mounted** Cm Pelet-set (pellet burner, pellet control unit, pellet feeder, pellet tank). For details see Technical instructions for the commissioning and adjustment of Cm Pelet-set for boilers EKO-CK P and EKO-CKB P.

If the supply cable of Cm Pelet-set control unit (CPREG), supply cable between control unit (CPREG) and pellet feeder (CPPT) or supply cable between control unit (CPREG) and burner (CPPL) is damaged, replacement can be done only by manufacturer, authorized serviceman or qualified persons in order to prevent possible danger.

7.0. CONTROL OF BOILER TEMPERATURE

Temperature in boiler is controlled by a digital boiler control unit CPREG which need to be further mounted (with pellet burner, pellet feeder and pellet tank). For detailed description of boiler control unit CPREG see Technical instructions for use and maintenance of Cm Pelet-set for boilers EKO-CK P and EKO-CKB P supplied with wooden pellet firing set.

8.0. CONNECTING BOILER TO ELECTRICAL INSTALLATIONS

All electrical works must be performed by a certified professional in accordance with valid national and European standards.

A device for switching of all power supply poles must be installed in electrical installation in accordance with the national regulations on electrical installations.

If the supply cable of Cm Pelet-set control unit (CPREG), supply cable between control unit (CPREG) and pellet feeder (CPPT) or supply cable between control unit (CPREG) and burner (CPPL) is damaged, replacement can be done only by manufacturer, authorized serviceman or qualified persons in order to prevent possible danger. For detailed description of electric connection see Technical instructions for the commissioning and adjustment of Cm Pelet-set for boilers EKO-CK P and EKO-CKB P.

9.0. START UP

Boiler must not be used in flammable and explosive environment.

It must not be used by children or disabled persons (either physically or mentally), as well as by person without knowledge or experience, unless they are under control or trained by a person responsible for their safety. Protective gloves are obligatory (Figure 5.). Check whether boiler and equipment are installed and connected in accordance with these Technical instructions including all points from 1.0 to this 8.0. Check whether chimney meets requirements of point 4.0 therein. Check whether boiler room meets all requirements therein. Check if fuel fulfils all requirements therein. Check whether the boiler and the entire heating system are filled with water and vented. Check whether safety elements have been correctly installed and in proper working order (see previous points of instructions). Check whether flue gas tube is sealed and thermally insulated. Check whether movable parts are placed to foreseen positions (upper lid, lower lid, turbulators in flue gas tubes grate of burner, ash tray) Figure 4.

Check whether all parts of pellet firing set are properly assembled and installed. Check whether boiler control unit CPREG is connected to power supply and whether all openings at boiler are closed tightly. For proper boiler operation it is necessary to set correctly control unit CPREG according to the boiler size and required output and to select pellets having properties given in point 10.0. Detailed description is given in Technical instructions for the commissioning and adjustment of Cm Pelet-set for boilers EKO-CK P and EKO-CKB P and Technical instruction for pellet tank and screw feeder supplied with equipment for firing with wooden pellets.

Figure 8. - Movable parts of the boiler

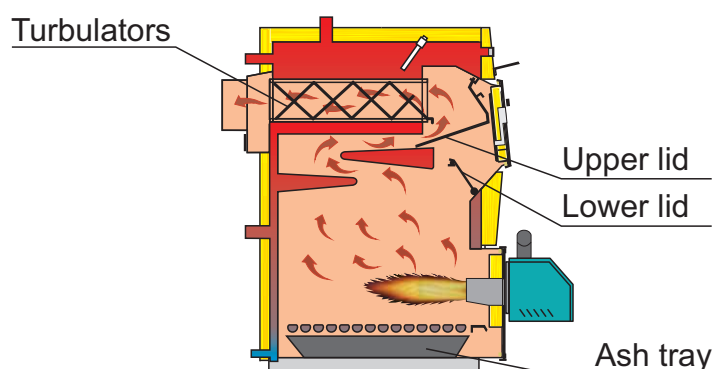

Figure 9. Protective gloves

Protective gloves are obligatory!



Figure 10. Boiler door opening method

GV - Upper boiler door
DV - Lower boiler door
RGV - Handles of upper boiler door
RDV - Handles of lower boiler door

Left Right
↔
Open Close
↑ ↓

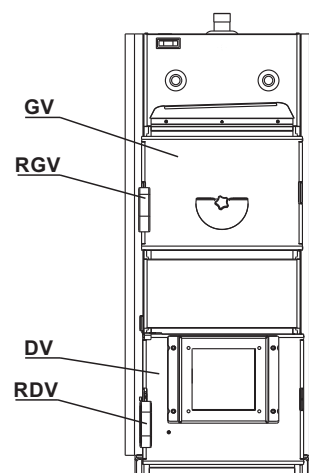

PROCESS OF OPENING BOILER DOOR:

UPPER BOILER DOOR:

1. Pull the handle of the upper boiler door RGV in direction of the arrow "OPEN".
2. Open the upper boiler door GV in direction of the arrow "RIGHT".

LOWER BOILER DOOR:

Lower boiler door - allowed to open only when the burner is not working (OFF is displayed in the upper display or control unit is OFF on main switch (0)).

1. Pull the handle of the lower boiler door RDV in direction of the arrow "OPEN".
2. Open the lower boiler door DV in direction of the arrow "RIGHT".

PROCESS OF CLOSING BOILER DOOR:

UPPER BOILER DOOR:

1. Pull the handle of the upper boiler door RGV in direction of the arrow "OPEN".
2. Press upper boiler door GV in direction of the arrow "LEFT".
3. Press the handle of the upper boiler door RGV in direction of the arrow "CLOSE".

LOWER BOILER DOOR:

1. Pull the handle of the lower boiler door RDV in direction of the arrow "OPEN".
2. Press lower boiler door DV in direction of the arrow "LEFT".
3. Press the handle of the upper boiler door RDV in direction of the arrow "CLOSE".

10.0. PROPERTIES OF WOODEN PELLETS

Wooden pellets are used as fuel in boilers with built-in pellet burner CPPL. Wooden pellets are bio-fuel made of wooden wastes. Pellets can be packed in different packaging: in bags (15 kg or 1000 kg), or as bulk in large (underground) tanks (4 - 15 m³) or in basement spaces. Recommended properties of pellets for firing in EKO-CK P boilers are the following:

- heating value ≥ 5 kWh/kg (18 MJ/kg)
- diameter ≤ 6 mm
- max. moisture content ≤ 12 %
- max. dust content $\leq 1,5$ %.

11.0. BOILER USE

Boiler must not be used in flammable and explosive environment.

It must not be used by children or disabled persons (either physically or mentally), as well as by person without knowledge or experience, unless they are under control or trained by a person responsible for their safety. Protective gloves are obligatory (Figure 9.). Check whether boiler and equipment are installed and connected in accordance with these Technical instructions including all points from 1.0 to this 8.0. Check whether chimney meets requirements of point 4.0 therein. Check whether boiler room meets all requirements therein. Check if fuel fulfils all requirements therein. Check whether the boiler and the entire heating system are filled with water and vented. Check whether safety elements have been correctly installed and in proper working order (see previous points of instructions). Check whether flue gas tube is sealed and thermally insulated. Check whether movable parts are placed to foreseen positions (upper lid, lower lid, turbulators in flue gas tubes grate of burner, ash tray) Figure 4.

Check whether all parts of pellet firing set are properly assembled and installed. Check whether boiler control unit CPREG is connected to power supply and whether all openings at boiler are closed tightly. For proper boiler operation it is necessary to set correctly control unit CPREG according to the boiler size and required output and to select pellets having properties given in point 10.0. Detailed description is given in Technical instructions for the commissioning and adjustment of Cm Pelet-set for boilers EKO-CK P and EKO-CKB P and Technical instruction for pellet tank and screw feeder supplied with equipment for firing with wooden pellets.

12.0. CLEANING AND MAINTENANCE OF THE BOILER AND EQUIPMENT FOR WOODEN PELLETS FIRING

Ash remaining in boiler after solid fuel firing should be disposed into metal containers with a cover. Protective gloves must be used (Figure 9).

Care should be taken of:

- Ash amount in ash trash and to empty it as required;
- Deposits in boiler firebox and to clean it as required;
- Deposit at burner grate and to clean it as required;
- Ash amount in the ash tray empty it as required

Cleaning:

First, main switch at boiler control unit has to be turned off.

The combustion chamber can be cleaned through upper and lower boiler door.

Open upper boiler door, take upper lid out, take turbulators out and clean flue gas pipe using supplied scraper. Open lower boiler door (with burner on it) and clean the combustion chamber, empty ash tray and clean the burner grate.

It is recommended to clean the burner and boiler combustion chamber after one pellet tank is consumed (approx. 200 kg).

Intervals between cleaning can be increase or decrease in relation to the recommended ones, as needed, and it depends on quality of used pellets (see 10.0) and turning on/off frequency of the burner. For maintenance and cleaning of equipment for pellet firing see Technical instructions for use and maintenance of Cm Pelet-set for boilers EKO-CK P and EKO-CKB P and Technical instructions for pellet tank and screw feeder.

Figure 11. - Take of movable lids from combustion chamber

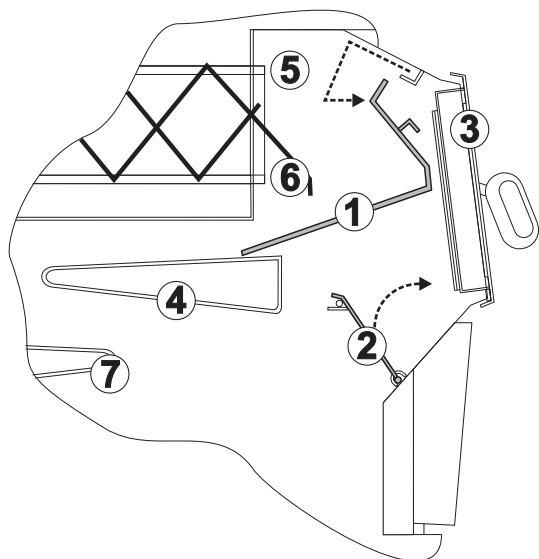

- ① - Upper lid
- ② - Lower lid
- ③ - Upper boiler door
- ④ - Upper register
- ⑤ - Flue gas pipe
- ⑥ - Turbulators
- ⑦ - Lower register

13.0. MOUNTING OF THE TURBULATORS

By wooden pellets firing turbulators must be mounted in the flue gas pipes. To mounting the turbulators is necessary to open upper boiler door, take out upper lid (position 1) (Figure 11.). Then, insert the turbulators into the flue gas pipes and push to the end (see figure 12.). After that, back in upper lid.

Figure 12. Mounting of turbulators

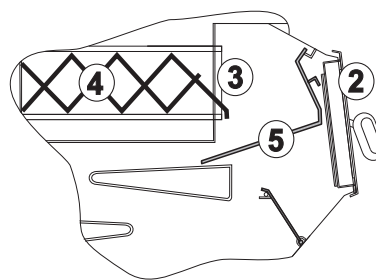
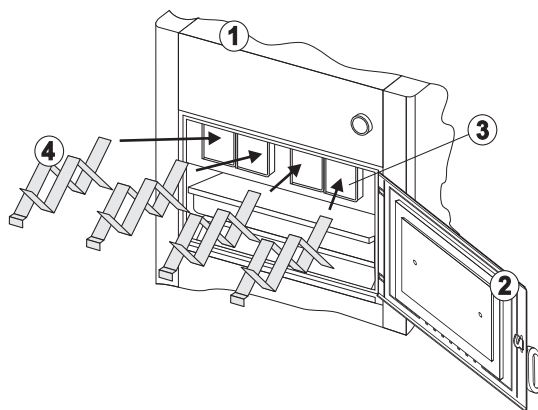

- ① - Boiler EKO-CK P or EKO-CKB P
- ② - Upper boiler door
- ③ - Flue gas pipe
- ④ - Turbulators
- ⑤ - Upper lid

