

Centrometal

HEATING TECHNIQUE

Centrometal d.o.o. - Glavna 12, 40306 Macinec, Croatia, tel: +385 40 372 600, fax: +385 40 372 611

Technical manual

R32

ENG

for installation, use and maintenance
of heat pump

CE



*Heat pumps Arctic
Mono series 22-30 kW*

CONTENTS

Part 1	General Information	3
Part 2	Engineering Data	8
Part 3	Installation and Field Settings	21

Part 1

General Information

1 System Configurations	4
2 Unit Capacities	5
3 Nomenclature	5
4 System Design and Unit Selection	6

1 System Configurations

Heat pump Mono can be configured to run with the electric heater either enabled or disabled, if the heater is connected to the system as an additional equipment, and can also be used in conjunction with an auxiliary heat source such as a boiler.

The chosen configuration affects the size of heat pump that is required. Three typical configurations are described below. Refer to Figure 1-1.1.

Configuration 1: Heat pump only

- The heat pump covers the required capacity and no extra heating capacity is necessary.
- Requires selection of larger capacity heat pump and implies higher initial investment.
- Ideal for new construction in projects where energy efficiency is paramount.

Configuration 2: Heat pump and backup electric heater

- Heat pump covers the required capacity until the ambient temperature drops below the point at which the heat pump is able to provide sufficient capacity. When the ambient temperature is below this equilibrium point (as shown in Figure 1-1.1), the backup electric heater supplies the required additional heating capacity.
- Best balance between initial investment and running costs, results in lowest lifecycle cost.
- Ideal for new construction.

Configuration 3: Heat pump with auxiliary heat source

- Heat pump covers the required capacity until the ambient temperature drops below the point at which the heat pump is able to provide sufficient capacity. When the ambient temperature is below this equilibrium point (as shown in Figure 1-1.1), depending on the system settings, either the auxiliary heat source supplies the required additional heating capacity or the heat pump does not run and the auxiliary heat source covers the required capacity.
- Enables selection of lower capacity heat pump.
- Ideal for refurbishments and upgrades.

Figure 1-1.1: System configurations

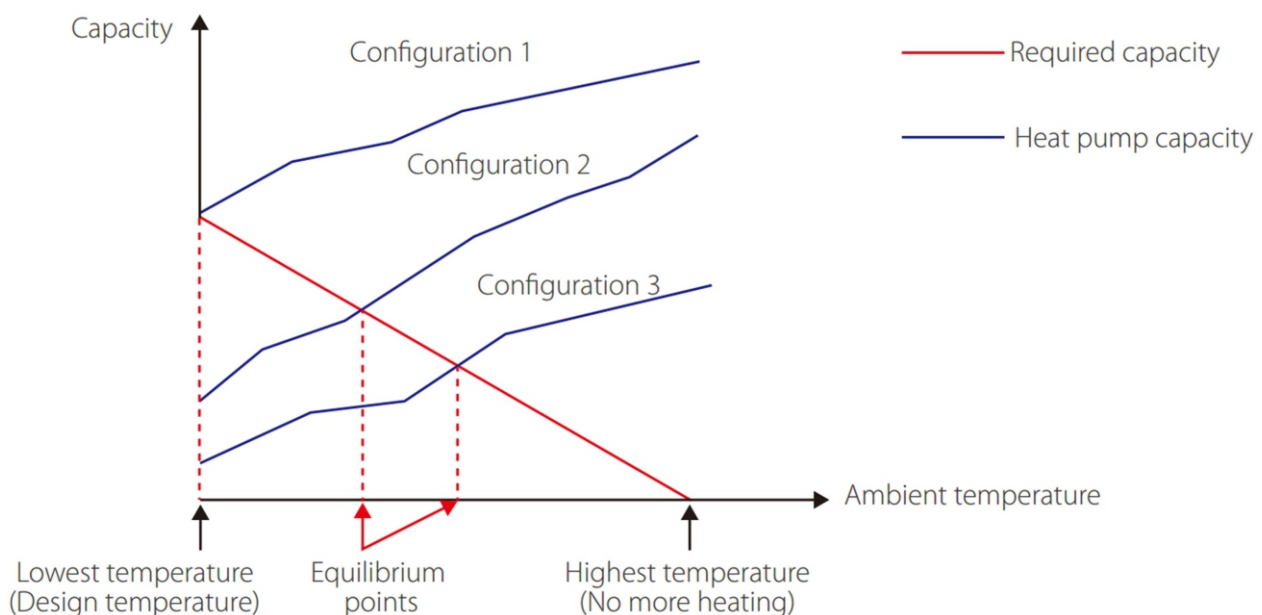

2 Unit Capacities

Table 1-2.1: Unit capacities range and appearances

Capacity	22 kW	30 kW
Model	MHPA22RP24P3CM	MHPA30RP24P3CM
Appearance		

3 Nomenclature

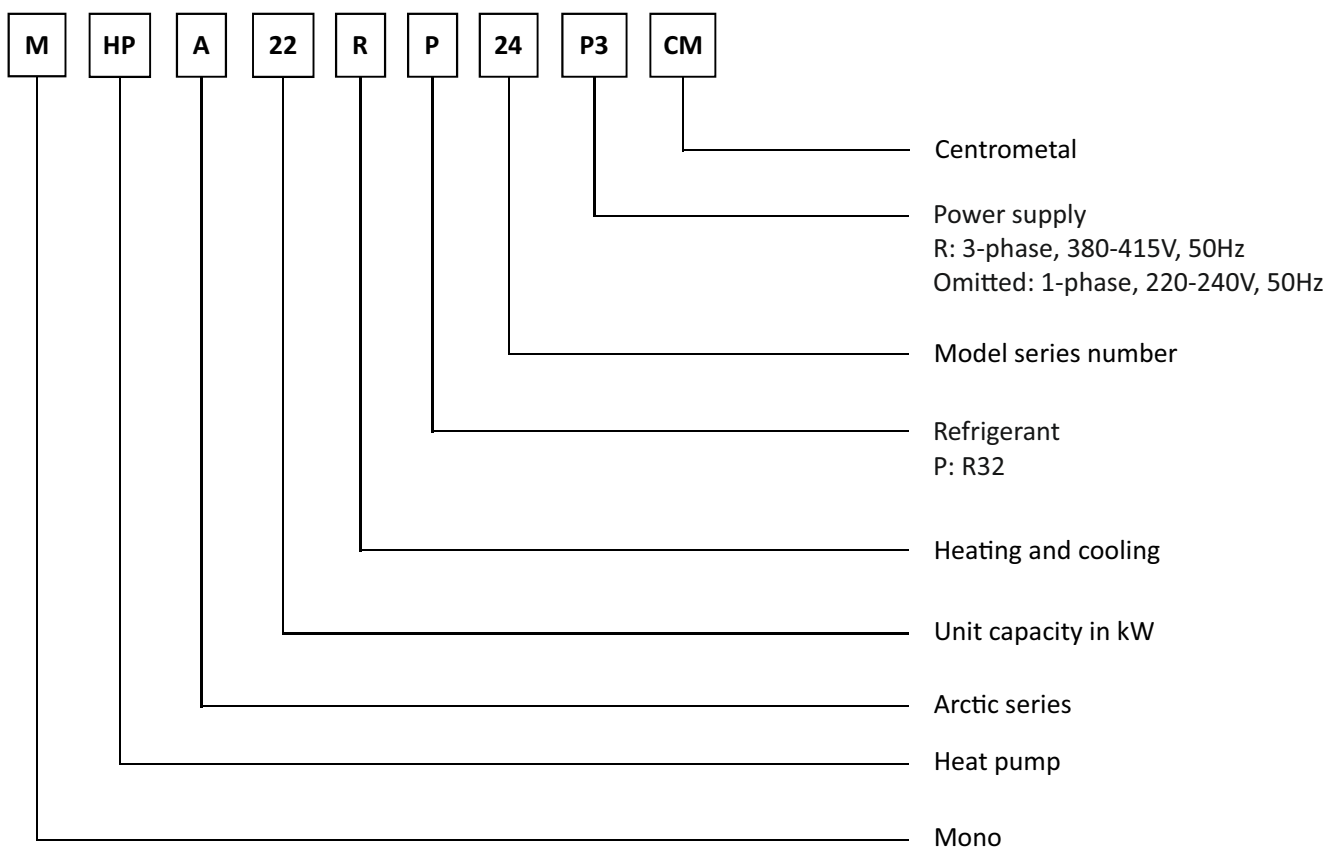

4 System Design and Unit Selection

4.1 Selection Procedure

Step 1: Total heat load calculation

Calculate total heat losses.
Select the heat emitters (type, quantity, water temperature and heat load).

Step 2: System configuration

Decide whether to include AHS and set AHS's switching temperature.
Decide whether backup electric heater is enabled or disabled.

Step 3: Selection of outdoor units

Determine required total heat load on outdoor units.
Set capacity safety factor.
Select power supply.

Provisionally select heat pump Mono unit capacity based on nominal capacity.

Correct capacity of the outdoor units for the following items:
Outdoor air temperature / Outdoor humidity / Water outlet temperature¹ /
Altitude / Anti-freeze fluid.

Is corrected heat pump Mono unit capacity \geq Required total heat load on outdoor units².

Yes

No

Heat pump Mono system selection is complete.

Select a larger model or enable backup electric heater operation.

Notes:

1. If the required water temperatures of the heat emitters are not all the same, the heat pump Mono's outlet water temperature setting should be set at the highest of the heat emitter required water temperatures. If the water outlet design temperature falls between two temperatures listed in the outdoor unit's capacity table, calculate the corrected capacity by interpolation.
2. Select Mono units which should satisfy both total heating and cooling load requirements.

4.2 Heat Pump Leaving Water Temperature (LWT) Selection

The recommended design LWT ranges for different types of heat emitter are:

- For floor heating: 30 to 35°C;
- For fan coil units: 30 to 45°C;
- For low temperature radiators: 40 to 50°C.

4.3 Optimizing System Design

To get the most comfort with the lowest energy consumption with heat pump, it is important to take account of the following considerations:

- Choose heat emitters that allow the heat pump system to operate at as low a hot water temperature as possible whilst still providing sufficient heating.
- Make sure the correct weather dependency curve is selected to match the installation environment (building structure, climate) as well as ender user's demands.
- Connecting room thermostats (field supplied) to the hydronic system helps prevent excessive space heating by stopping the outdoor unit and circulator pump when the room temperature is above the thermostat set point.

4.4 Selection of the buffer tank and DHW tank

4.4.1 Selection of the buffer tank

The heat pump must be connected to the buffer tank in order to satisfy the minimum amount of water in the system. The volume of the buffer tank must be selected according to table 1-4.1.

Table 1-4.1: Minimum buffer tank volume

Model	Buffer tank [L]
22-30 kW	≥40
cascade	≥40*n

n = number of heat pumps in cascade

4.4.2 Selection of the DHW tank

The heat pump can be connected to the DHW tank. The tank can be with or without a built-in electric heater. The electric heater of the DHW tank must be installed below the tank temperature sensor. The tank temperature sensor must be above the heat exchangers in the tank. For the correct operation of the DHW heating system with a heat pump, it is necessary to comply with the minimum requirements of the DHW tank given in table 1-4.2.

Table 1-4.2: Minimum requirements of the DHW tank

Model		22-30 kW
DHW tank volume [L]	Recommended	300-500 ili više
Heat exchanger area - stainless steel coil [m ²]	Minimum	3,5
Heat exchanger area - enamel coil [m ²]	Minimum	5,0

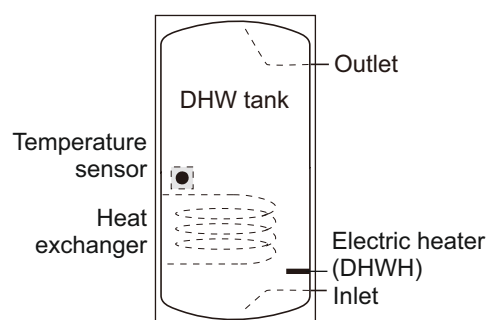

Part 2

Engineering Data

1 Specifications	9
2 Dimensions and Center of Gravity	10
3 Piping Diagrams	11
4 Wiring Diagrams	12
5 Capacity Tables	13
6 Operating Limits	16
7 Hydronic Performance	17
8 Sound Levels	18
9 Accessories	20

1 Specifications

Table 2-1.1: MHPA22(30)RP24P3CM specifications¹

Model name			MHPA22RP24P3CM	MHPA30RP24P3CM
Power supply		V/Ph/Hz	380-415/3/50	
Heating (A7W35)	Capacity	W	22000	30100
	Rated input	W	5000	7698
	COP		4.40	3.91
Heating (A7W45)	Capacity	W	22000	30000
	Rated input	W	6471	10345
	COP		3.40	2.90
Heating (A7W55)	Capacity	W	22000	30000
	Rated input	W	8302	13043
	COP		2.65	2.30
Heating (A-7W35)	Capacity	W	21000	23000
	Rated input	W	8077	9388
	COP		2.60	2.45
Cooling (A35W18)	Capacity	W	23000	31000
	Rated input	W	5000	7750
	EER		4.60	4.00
Cooling (A35W7)	Capacity	W	21000	29500
	Rated input	W	7119	11569
	EER		2.95	2.55
Seasonal space heating energy efficiency class	Water outlet at 35°C / 55°C	class	A+++ / A++	A++ / A+
SCOP	Warmer climate	35°C	5.93	5.40
		55°C	4.10	4.15
	Average climate	35°C	4.53	4.20
		55°C	3.23	3.15
	Colder climate	35°C	3.73	3.53
		55°C	2.63	2.58
SEER	Water outlet at 7°C / 18°C		4.70 / 5.67	4.49 / 5.71
MOP / MCA	A		21.0 / 24.5	28.0 / 28.5
Compressor	Type		Twin rotary DC inverter	
Outdoor fan motor	Type		Brushless DC motor	
Water side heat exchanger			Plate type	
Water pump	Max. pump head	m	12	12
Refrigerant (R32)	Charged volume	kg	5.0	
Throttle type			Electronic expansion valve	
Sound power level ²		dB	73	77
Rated water flow		m ³ /h	3.78	5.18
Internal water volume		L	3.5	3.5
Unit dimension / Packing dimension (W×H×D)		mm	1129×1558×440 / 1220×1735×565	
Net / Gross weight		kg	177 / 206	
Water piping connections Dia.		inch	1-1/4" BSP	1-1/4" BSP
Ambient temperature range	Cooling	°C	-5 to 46	

Ambient temperature range	Heating	°C	-25 to 35
	DHW	°C	-25 to 43
Water setting temperature range	Cooling	°C	5 to 25
	Heating	°C	25 to 60
	DHW ³	°C	30 to 60

Notes:

1. Relevant EU standards and legislation: EN14511; EN14825; EN50564; EN12102; (EU) No 811/2013; (EU) No 813/2013; OJ 2014/C 207/02.
2. Test standard: EN12102-1.
3. Maximum domestic hot water temperature 60°C is only available with TBH support.

2 Dimensions and Center of Gravity

Figure 2-2.1: MHPA22(30)RP24P3CM dimensions and center of gravity (unit: mm)

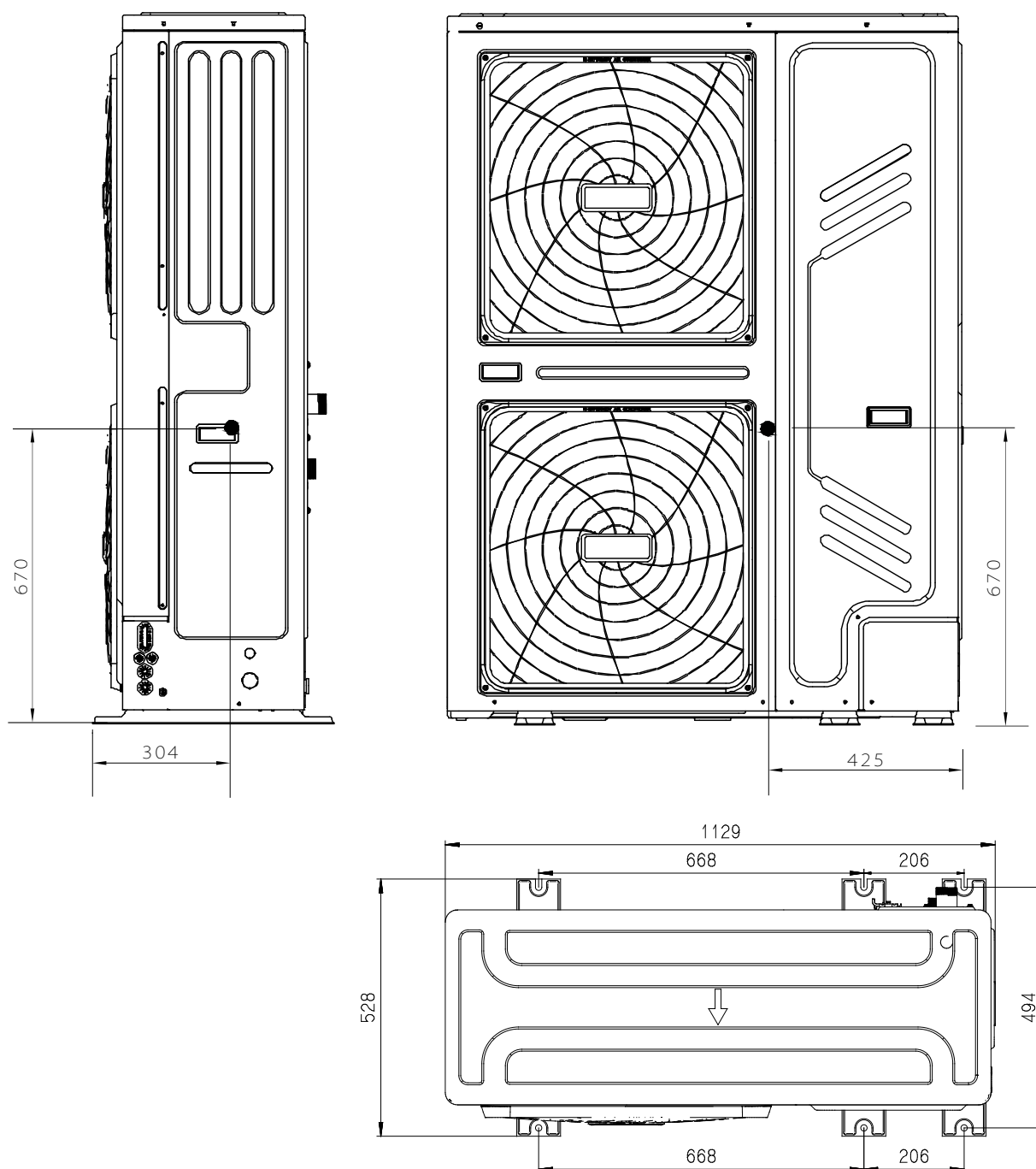

3 Piping Diagrams

Figure 2-3.1: MHPA22(30)RP24P3CM piping diagram

Number	Sensor name	Sensor code
1	Suction pipe temperature sensor	Th
2	Discharge pipe temperature sensor	Tp
3	Outdoor ambient temperature sensor	T4
4	Air side heat exchanger refrigerant outlet temperature sensor	T3
5	Water side heat exchanger refrigerant outlet (gas pipe) temperature sensor	T2B
6	Water side heat exchanger refrigerant outlet (liquid pipe) temperature sensor	T2
7	Water side heat exchanger water outlet temperature sensor	Tw_out
8	Water side heat exchanger water inlet temperature sensor	Tw_in
9	Final water outlet temperature sensor	T1
10	Domestic hot water tank temperature sensor	T5
11	Room temperature sensor (Built-in controller)	Ta

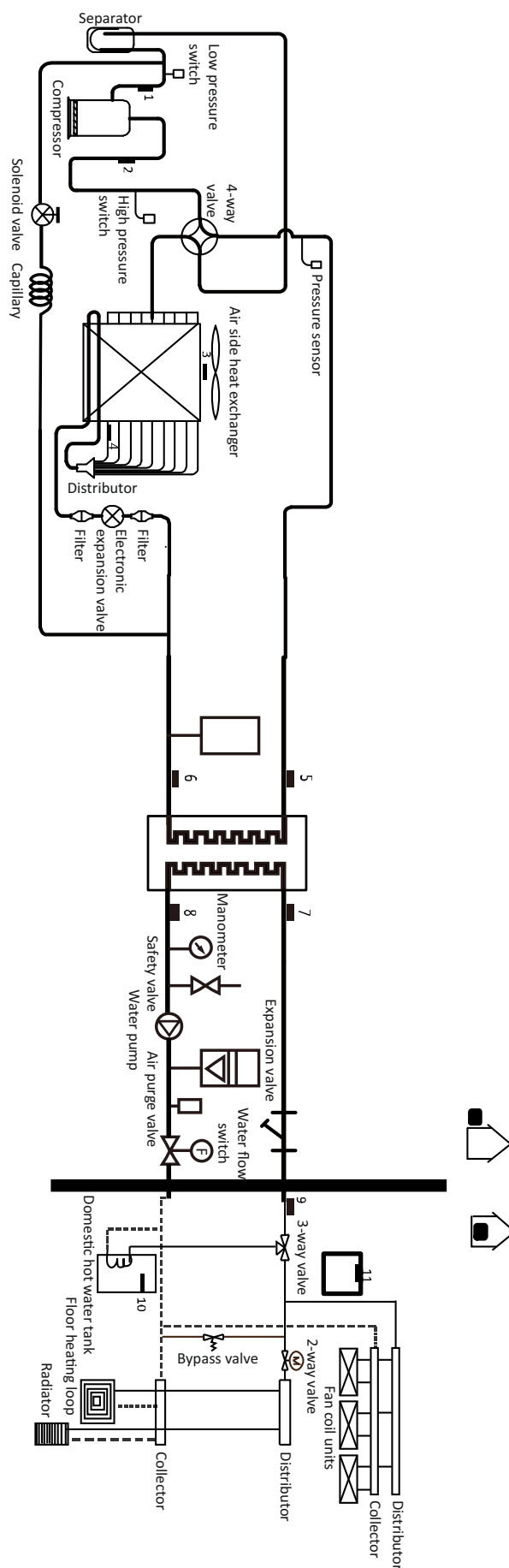

4 Wiring Diagrams

4.1 Wiring Diagrams

Figure 2-4.1: MHPA22(30)RP24P3CM wiring diagram

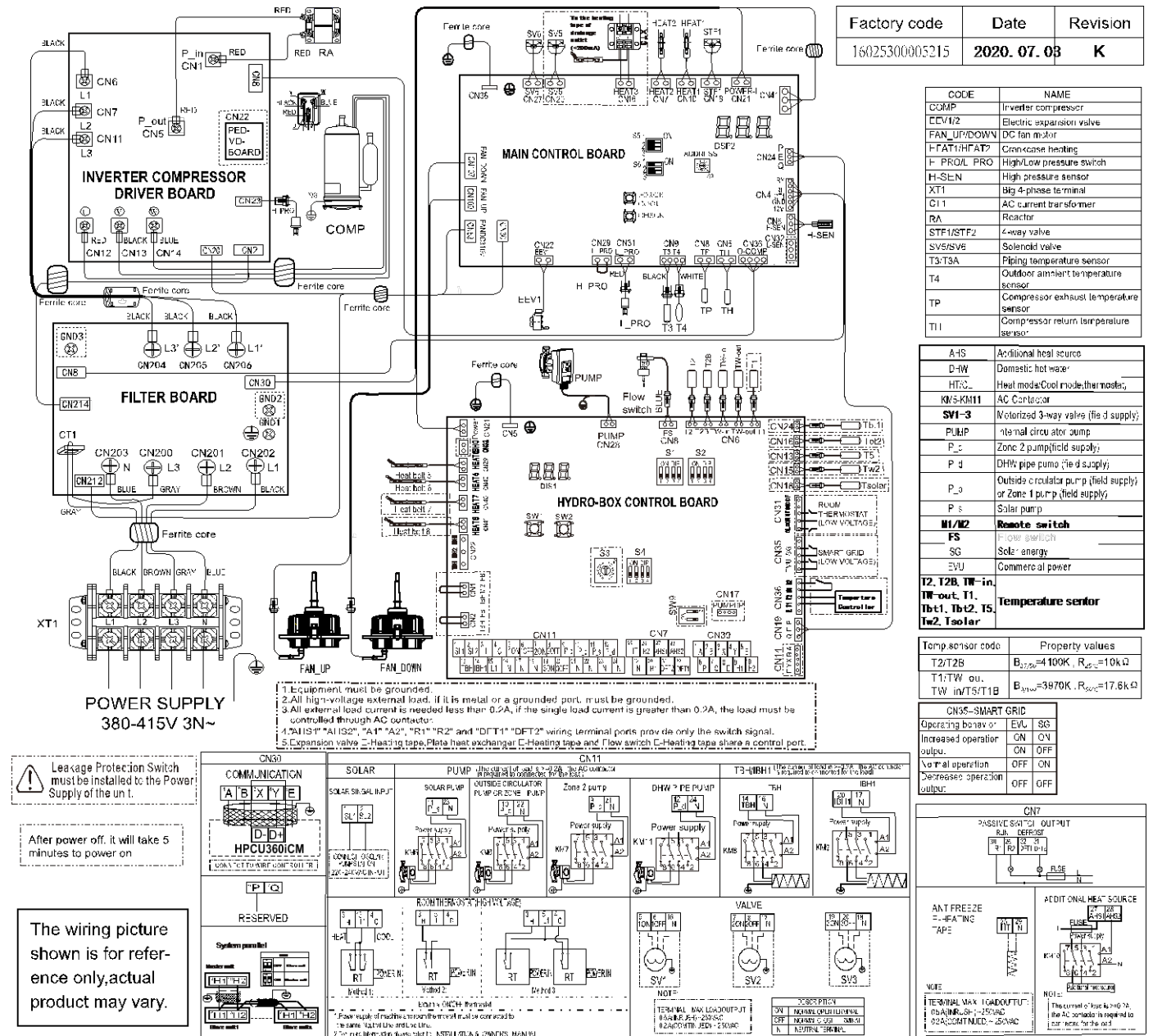

4.2 Recommended wire cross-sectional area and circuit breakers

Table 2-4.1: Wire cross-sectional area and circuit breakers

Model	Power supply (V/Ph/Hz)	Nominal cross-sectional area (mm ²)	Circuit breaker (A)/ph
MHPA22RP24P3CM	380-415/3/50	5x4.0	B25/3ph
MHPA30RP24P3CM	380-415/3/50	5x4.0	B32/3ph

5 Capacity Tables

5.1 Heating Capacity Tables (Test standard: EN14511)

Table 2-5.1: MHPA22RP24P3CM heating capacity - peak values¹

Outdoor air temp.	LWT (°C)																				
	30			35			40			45			50			55			60		
°C DB	HC	PI	COP	HC	PI	COP	HC	PI	COP	HC	PI	COP	HC	PI	COP	HC	PI	COP	HC	PI	COP
-25.0	10174	6756	1.51	9123	7154	1.28															
-20.0	12899	6067	2.13	11566	6424	1.80	10234	6782	1.51												
-15.0	20342	7021	2.90	19112	8206	2.33	17973	9705	1.85	16782	11251	1.49	14704	11423	1.29						
-10	22770	7972	2.86	22000	8861	2.48	21609	9866	2.19	21191	10901	1.94	18987	10952	1.73	12202	10922	1.12	8529	7893	1.08
-7.0	24093	8271	2.91	23733	9254	2.56	23791	9963	2.39	23836	10691	2.23	21846	10470	2.09	13558	10441	1.30	9946	8124	1.22
-5.0	25944	8376	3.10	25423	9289	2.74	25347	10043	2.52	25252	10817	2.33	23008	10627	2.16	15564	10743	1.45	12091	9304	1.30
-2.0	28722	8702	3.30	27958	9343	2.99	27680	10163	2.72	27375	11005	2.49	23397	10626	2.20	18573	11196	1.66	14958	11305	1.32
0	28274	8037	3.52	27530	8709	3.16	26787	9382	2.86	26043	10054	2.59	24722	10978	2.25	21601	10987	1.97	19108	11100	1.72
2	29878	7993	3.74	29100	8743	3.33	28321	9492	2.98	27542	10242	2.69	27112	10959	2.47	24629	10778	2.29	22717	11224	2.02
5	24792	6189	4.01	23920	6684	3.58	23049	7178	3.21	22177	7673	2.89	21966	8497	2.59	21754	9321	2.33	21543	10344	2.08
7.0	25997	6215	4.18	24925	6468	3.85	23891	7096	3.37	22657	7511	3.02	22706	8542	2.66	22775	9089	2.51	22443	10552	2.13
10	25467	5928	4.30	24549	6290	3.90	23631	6652	3.55	22713	7015	3.24	22316	7676	2.91	21919	8337	2.63	21521	8999	2.39
15.0	28916	6484	4.46	28048	6789	4.13	27180	7095	3.83	26312	7401	3.56	25450	7657	3.32	24588	7913	3.11	23726	8169	2.90
20.0	28642	6171	4.64	27752	6407	4.33	26862	6644	4.04	25972	6881	3.77	24963	7064	3.53	23953	7248	3.30	22944	7431	3.09
25.0	28913	6010	4.81	27988	6192	4.52	27063	6373	4.25	26138	6555	3.99	24984	6679	3.74	23830	6803	3.50	22676	6928	3.27
30.0	30920	6224	4.97	29906	6364	4.70	28892	6505	4.44	27878	6645	4.20	26518	6722	3.95	25158	6798	3.70	23799	6875	3.46
35.0	12748	1735	7.35	12458	1923	6.48	12167	2110	5.77	11877	2298	5.17	11536	2619	4.41	11196	2940	3.81			

Abbreviations:

LWT: Leaving water temperature (°C)

HC: Total heating capacity (W)

PI: Power input (W)

Notes:

1. Peak heating capacity values do not take account of capacity drops caused by frost accumulation and during defrosting.

Table 2-5.2: MHPA22RP24P3CM heating capacity - integrated values¹

Outdoor air temp.	LWT (°C)																				
	30			35			40			45			50			55			60		
°C DB	HC	PI	COP	HC	PI	COP	HC	PI	COP	HC	PI	COP	HC	PI	COP	HC	PI	COP	HC	PI	COP
-25.0	8726	6366	1.37	8064	6892	1.17															
-20.0	11062	5716	1.94	10223	6188	1.65	9383	6660	1.41												
-15.0	16554	6653	2.49	15913	7348	2.17	14860	9099	1.63	13761	10907	1.26	12571	11272	1.12						
-10	20427	8048	2.54	19266	8196	2.35	18429	9176	2.01	17550	10186	1.72	15221	10274	1.48	10648	10010	1.06	7442	7234	1.03
-7.0	22348	8404	2.66	21279	8704	2.44	20570	9223	2.23	19824	9754	2.03	17426	9425	1.85	12547	10034	1.25	9204	7904	1.16
-5.0	23094	8219	2.81	22113	8611	2.57	21508	9221	2.33	20869	9847	2.12	18483	9601	1.93	13813	10050	1.37	10731	8985	1.19
-2.0	24215	8052	3.01	23364	8471	2.76	22915	9219	2.49	22435	9988	2.25	18925	9595	1.97	15713	10074	1.56	13392	10067	1.33
0	22920	7140	3.21	22469	7779	2.89	22018	8417	2.62	21568	9056	2.38	20738	9947	2.08	18377	10003	1.84	16511	10149	1.63
2	23355	6959	3.36	23244	7692	3.02	23132	8425	2.75	23021	9157	2.51	22908	9959	2.30	21042	9933	2.12	19629	10005	1.96
5	23541	6021	3.91	22623	6460	3.50	21704	6900	3.15	20786	7340	2.83	20672	8189	2.52	20559	9039	2.27	20445	9889	2.07
7.0	25997	6215	4.18	24925	6468	3.85	23891	7096	3.37	22657	7511	3.02	22706	8542	2.66	22775	9089	2.51	22443	10552	2.13
10	25467	5928	4.30	24549	6290	3.90	23631	6652	3.55	22713	7015	3.24	22316	7676	2.91	21919	8337	2.63	21521	8999	2.39
15.0	28916	6484	4.46	28048	6789	4.13	27180	7095	3.83	26312	7401	3.56	25450	7657	3.32	24588	7913	3.11	23726	8169	2.90
20.0	28642	6171	4.64	27752	6407	4.33	26862	6644	4.04	25972	6881	3.77	24963	7064	3.53	23953	7248	3.30	22944	7431	3.09
25.0	28913	6010	4.81	27988	6192	4.52	27063	6373	4.25	26138	6555	3.99	24984	6679	3.74	23830	6803	3.50	22676	6928	3.27
30.0	30920	6224	4.97	29906	6364	4.70	28892	6505	4.44	27878	6645	4.20	26518	6722	3.95	25158	6798	3.70	23799	6875	3.46
35.0	12748	1735	7.35	12458	1923	6.48	12167	2110	5.77	11877	2298	5.17	11536	2619	4.41	11196	2940	3.81			

Abbreviations:

LWT: Leaving water temperature (°C)

HC: Total heating capacity (W)

PI: Power input (W)

Notes:

1. Integrated heating capacity values take account of capacity drops caused by frost accumulation and during defrosting.

Table 2-5.3: MHPA30RP24P3CM heating capacity - peak values¹

Outdoor air temp.	LWT (°C)																				
	30			35			40			45			50			55			60		
°C DB	HC	PI	COP	HC	PI	COP	HC	PI	COP	HC	PI	COP	HC	PI	COP	HC	PI	COP	HC	PI	COP
-25.0	10495	7989	1.31	9553	8439	1.13															
-20.0	13266	6606	2.01	12076	6976	1.73	10887	7347	1.48												
-15.0	21600	6060	3.56	19955	8898	2.24	18873	11790	1.60	17740	14777	1.20	17283	16036	1.08						
-10	23336	7831	2.98	23038	9542	2.41	23147	11270	2.05	23245	13053	1.78	22937	14639	1.57	14692	13080	1.12	11046	9807	1.13
-7.0	24516	9090	2.70	24888	9928	2.51	25711	10959	2.35	26547	12019	2.21	26933	12887	2.09	22278	14100	1.58	16470	12795	1.29
-5.0	27005	9411	2.87	26704	10109	2.64	26874	11001	2.44	27033	11917	2.27	26721	12641	2.11	23263	14564	1.60	19236	12538	1.53
-2.0	30739	9892	3.11	29428	10381	2.83	28618	11064	2.59	27762	11765	2.36	27612	12944	2.13	27907	14716	1.90	27664	17438	1.59
0	32612	9711	3.36	31244	10562	2.96	30409	11617	2.62	29526	12703	2.32	29993	13980	2.15	29409	14730	2.00	28335	14653	1.93
2	33318	8907	3.74	31942	9481	3.37	31111	11374	2.74	30700	12748	2.41	30582	13511	2.26	29866	13781	2.17	28047	13980	2.01
5	31830	8363	3.81	31020	9257	3.35	30791	10348	2.98	30532	11310	2.70	30387	12427	2.45	29919	13651	2.19	28984	14005	2.07
7.0	31177	8100	3.85	31754	9509	3.34	30825	9810	3.14	30992	11268	2.75	31077	12097	2.57	30563	13819	2.21	27332	12943	2.11
10	30030	7459	4.03	30099	8373	3.59	30837	9493	3.25	31579	10654	2.96	30903	11281	2.74	30172	11925	2.53	27033	11579	2.33
15.0	31835	7396	4.30	32695	8637	3.79	34334	10108	3.40	36014	11636	3.09	34020	11332	3.00	32585	11237	2.90	27197	9762	2.79
20.0	32636	7055	4.63	32977	8075	4.08	34150	9322	3.66	35340	10620	3.33	33608	10510	3.20	32477	10618	3.06	27137	9328	2.91
25.0	33876	6869	4.93	33763	7710	4.38	34535	8776	3.94	35302	9885	3.57	33766	9942	3.40	32877	10226	3.22	27519	9093	3.03
30.0	36747	7036	5.22	36198	7749	4.67	36587	8684	4.21	36947	9657	3.83	35488	9862	3.60	34721	10306	3.37	29225	9313	3.14
35.0	12696	1782	7.12	12405	1972	6.29	12113	2161	5.61	11821	2351	5.03	11577	2665	4.34	11333	2979	3.80			

Abbreviations:

LWT: Leaving water temperature (°C)

HC: Total heating capacity (W)

PI: Power input (W)

Notes:

1. Peak heating capacity values do not take account of capacity drops caused by frost accumulation and during defrosting.

Table 2-5.4: MHPA30RP24P3CM heating capacity - integrated values¹

Outdoor air temp.	LWT (°C)																				
	30			35			40			45			50			55			60		
°C DB	HC	PI	COP	HC	PI	COP	HC	PI	COP	HC	PI	COP	HC	PI	COP	HC	PI	COP	HC	PI	COP
-25.0	8886	7322	1.21	8680	8019	1.08															
-20.0	11249	6302	1.79	10773	6901	1.56	10288	7500	1.37												
-15.0	17880	6930	2.58	17595	8523	2.06	16194	11075	1.46	14691	13737	1.07	14318	13687	1.05						
-10	22178	8749	2.53	21136	9400	2.25	20434	10862	1.88	19671	12377	1.59	18172	13423	1.35	14290	13635	1.05	10381	10223	1.02
-7.0	23940	9425	2.54	23261	9927	2.34	22977	10735	2.14	22659	11561	1.96	21508	11943	1.80	16540	13786	1.20	12228	11043	1.11
-5.0	24368	9278	2.63	23897	9874	2.42	23842	10779	2.21	23766	11708	2.03	22825	12188	1.87	18040	13480	1.34	13933	11348	1.23
-2.0	25011	9301	2.69	24851	9795	2.54	25138	10846	2.32	25427	11928	2.13	23246	12272	1.89	19934	12793	1.56	17952	12818	1.40
0	25440	8787	2.90	25487	9742	2.62	26003	10891	2.39	26534	12075	2.20	25278	12619	2.00	22724	13080	1.74	21611	13039	1.66
2	24994	8075	3.10	26021	9085	2.86	25959	10220	2.54	28191	12317	2.29	26388	11998	2.20	24651	12493	1.97	23085	11821	1.95
5	28738	8054	3.57	28531	8892	3.21	28875	9918	2.91	29219	10978	2.66	28825	11863	2.43	27846	13110	2.12	27000	13141	2.05
7.0	31177	8100	3.85	31754	9509	3.34	30825	9810	3.14	30992	11268	2.75	31077	12097	2.57	30563	13819	2.21	27332	12943	2.11
10	30030	7459	4.03	30099	8373	3.59	30837	9493	3.25	31579	10654	2.96	30903	11281	2.74	30172	11925	2.53	27033	11579	2.33
15.0	31835	7396	4.30	32695	8637	3.79	34334	10108	3.40	36014	11636	3.09	34020	11332	3.00	32585	11237	2.90	27197	9762	2.79
20.0	32636	7055	4.63	32977	8075	4.08	34150	9322	3.66	35340	10620	3.33	33608	10510	3.20	32477	10618	3.06	27137	9328	2.91
25.0	33876	6869	4.93	33763	7710	4.38	34535	8776	3.94	35302	9885	3.57	33766	9942	3.40	32877	10226	3.22	27519	9093	3.03
30.0	36747	7036	5.22	36198	7749	4.67	36587	8684	4.21	36947	9657	3.83	35488	9862	3.60	34721	10306	3.37	29225	9313	3.14
35.0	12696	1782	7.12	12405	1972	6.29	12113	2161	5.61	11821	2351	5.03	11577	2665	4.34	11333	2979	3.80			

Abbreviations:

LWT: Leaving water temperature (°C)

HC: Total heating capacity (W)

PI: Power input (W)

Notes:

1. Integrated heating capacity values take account of capacity drops caused by frost accumulation and during defrosting.

5.2 Cooling Capacity Tables (Test standard: EN14511)

Table 2-5.5: MHPA22RP24P3CM cooling capacity

Outdoor air temp.	LWT (°C)																							
	25			22			18			15			13			10			7			5		
°C DB	CC	PI	EER	CC	PI	EER	CC	PI	EER	CC	PI	EER	CC	PI	EER	CC	PI	EER	CC	PI	EER	CC	PI	EER
45	24059	5909	4.07	21857	5984	3.65	18920	6083	3.11	20753	7644	2.72	19982	8133	2.46	18394	8281	2.22	15755	8000	1.97	13996	7813	1.79
40	25547	5289	4.83	23508	5498	4.28	20790	5775	3.60	23278	7428	3.13	22791	8022	2.84	21085	8083	2.61	18179	7722	2.35	16242	7481	2.17
35	31695	5475	5.79	29498	5876	5.02	26568	6410	4.14	25804	7212	3.58	25600	7911	3.24	23775	7886	3.01	20873	7120	2.93	18938	6609	2.87
30	32805	4833	6.79	30457	5113	5.96	27325	5487	4.98	26491	6117	4.33	26249	6675	3.93	24797	6818	3.64	21925	6599	3.32	20011	6453	3.10
25	29567	3694	8.01	27392	3839	7.14	24491	4032	6.07	24706	4625	5.34	23846	4885	4.88	23026	5184	4.44	20716	5179	4.00	19176	5175	3.71
20	26423	3223	8.20	25189	3389	7.43	23542	3609	6.52	21581	3677	5.87	21775	3998	5.45	21025	4352	4.83	18773	4429	4.24	17272	4481	3.85
15	21288	2537	8.39	21105	2718	7.76	20861	2960	7.05	19239	2957	6.51	19671	3200	6.15	19292	3442	5.60	17399	3437	5.06	16138	3434	4.70
10	18223	2153	8.46	17097	2102	8.13	15597	2034	7.67	16079	2204	7.30	16770	2383	7.04	16794	2531	6.63						
5	14462	1734	8.34	13538	1686	8.03	12306	1622	7.59	13820	1911	7.23	14610	2093	6.98	14762	2241	6.59						
0	22126	2691	8.22	20667	2606	7.93	18721	2493	7.51	17261	2408	7.17	16288	2352	6.93	14829	2267	6.54						
-5	18833	3765	5.00	17543	3550	4.94	15824	3264	4.85	14535	3049	4.77	13675	2906	4.71	12386	2691	4.60						

Abbreviations:

LWT: Leaving water temperature (°C)

CC: Total cooling capacity (kW)

PI: Power input (kW)

Table 2-5.6: MHPA30RP24P3CM cooling capacity

Outdoor air temp.	LWT (°C)																							
	25			22			18			15			13			10			7			5		
°C DB	CC	PI	EER	CC	PI	EER	CC	PI	EER	CC	PI	EER	CC	PI	EER	CC	PI	EER	CC	PI	EER	CC	PI	EER
45	24524	5595	4.38	22109	5778	3.83	18890	6023	3.14	20452	7705	2.65	18454	7857	2.35	18197	8596	2.12	16403	8680	1.89	15206	8736	1.74
40	26438	5410	4.89	24108	5726	4.21	21002	6148	3.42	27686	9586	2.89	25383	9898	2.56	24621	10227	2.41	22087	9866	2.24	20399	9625	2.12
35	34379	6180	5.56	33308	7240	4.60	31881	8653	3.68	35981	11591	3.10	33401	12107	2.76	30194	11214	2.69	29736	12705	2.34	29431	13699	2.15
30	41579	7118	5.84	38295	7474	5.12	33917	7949	4.27	38293	10380	3.69	35557	10677	3.33	35512	11169	3.18	31911	10593	3.01	29511	10210	2.89
25	44052	7030	6.27	40581	7121	5.70	35954	7244	4.96	36544	8253	4.43	35450	8692	4.08	33685	8912	3.78	30412	8762	3.47	28230	8662	3.26
20	38765	5925	6.54	35944	5916	6.08	32183	5904	5.45	30993	6223	4.98	30535	6544	4.67	30825	7350	4.19	25479	6850	3.72	21915	6516	3.36
15	32622	4756	6.86	30453	4670	6.52	27561	4554	6.05	26212	4612	5.68	26264	4837	5.43	25291	5020	5.04	22772	4920	4.63	21093	4853	4.35
10	28779	3984	7.22	27055	3834	7.06	24757	3635	6.81	25502	3859	6.61	25011	3869	6.46	24481	3929	6.23						
5	19577	3160	6.20	18535	3123	5.94	17145	2887	5.94	17712	2981	5.94	18488	3110	5.94	18674	3139	5.95						
0	24178	4426	5.46	23068	4559	5.06	21587	4131	5.23	20477	3809	5.38	19737	3595	5.49	18627	3273	5.69						
-5	28578	4067	7.03	26544	3815	6.96	23832	3478	6.85	21798	3225	6.76	20442	3057	6.69	18408	2804	6.56						

Abbreviations:

LWT: Leaving water temperature (°C)

CC: Total cooling capacity (kW)

PI: Power input (kW)

6 Operating Limits

Figure 2-6.1: Heating operating limits

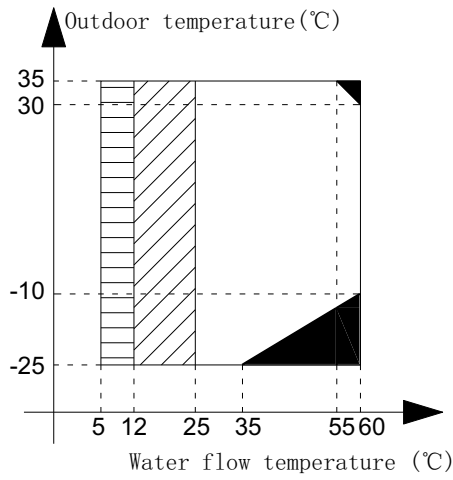

Figure 2-6.2: Cooling operating limits

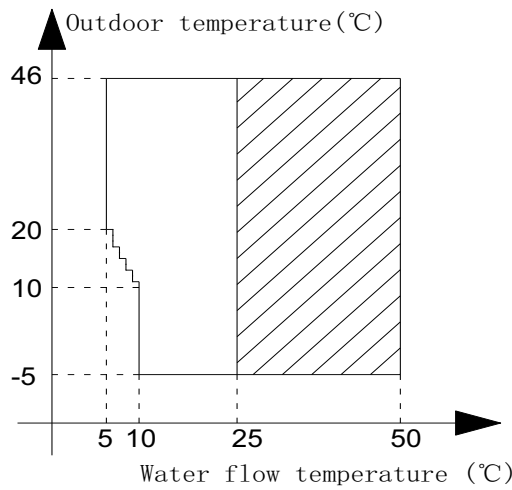
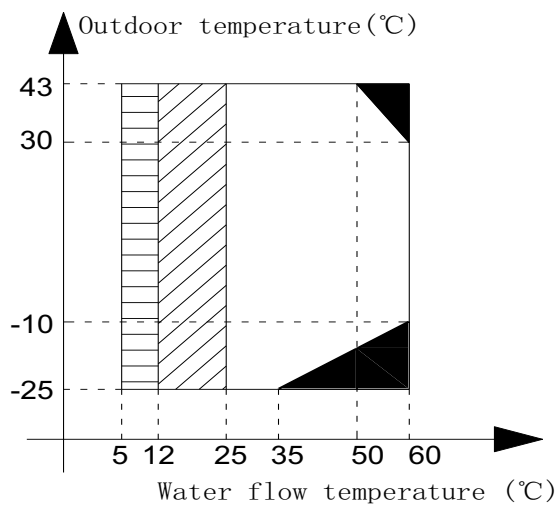

Figure 2-6.3: Domestic hot water operating limits



Notes:

- Shaded areas indicate no heat pump operation, IBH or AHS only.
- ▨ Shaded areas indicate water flow temperature drop or rise interval.
- ▤ Shaded areas indicates if IBH/AHS setting is valid, only IBH/AHS turns on. If IBH/AHS setting is invalid, only heat pump turns on.

7 Hydronic Performance

Figure 2-7.1: MHPA22(30)RP24P3CM hydronic performance¹

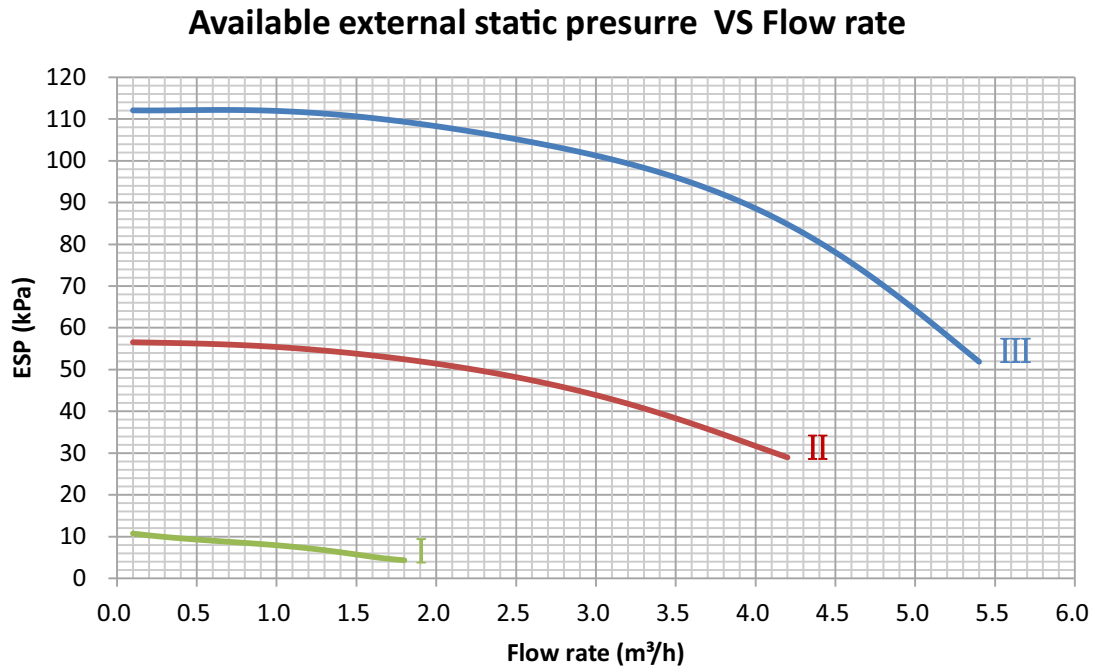

Abbreviations:

ESP: External static pressure

Notes:

1. I, II and III indicate water pump speed:

I: Low

II: Medium

III: High.

8 Sound Levels

8.1 Overall

Table 2-8.1: Sound pressure levels¹

Model name	dB(A) ²
MHPA22RP24P3CM	59.8
MHPA30RP24P3CM	63.5

Notes:

1. Sound pressure level is measured at a position 1m in front of the unit and $(1+H)/2$ m (where H is the height of the unit) above the floor in a semi-anechoic chamber. During in-situ operation, sound pressure levels may be higher as a result of ambient noise.

Figure 2-8.1: Sound pressure level measurement (unit: mm)

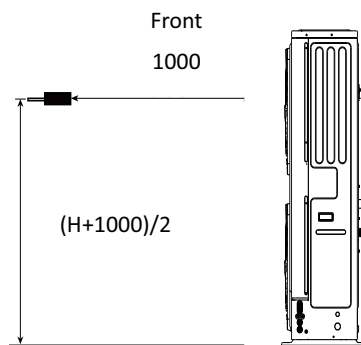

2. dB(A) is the maximum value tested under the conditions below:
 Outdoor air temperature 7°C DB, 85% R.H.; EWT 30°C, LWT 35°C.
 Outdoor air temperature 7°C DB, 85% R.H.; EWT 47°C, LWT 55°C.

8.2 Octave Band Levels

Figure 2-8.2: MHPA22RP24P3CM octave band levels

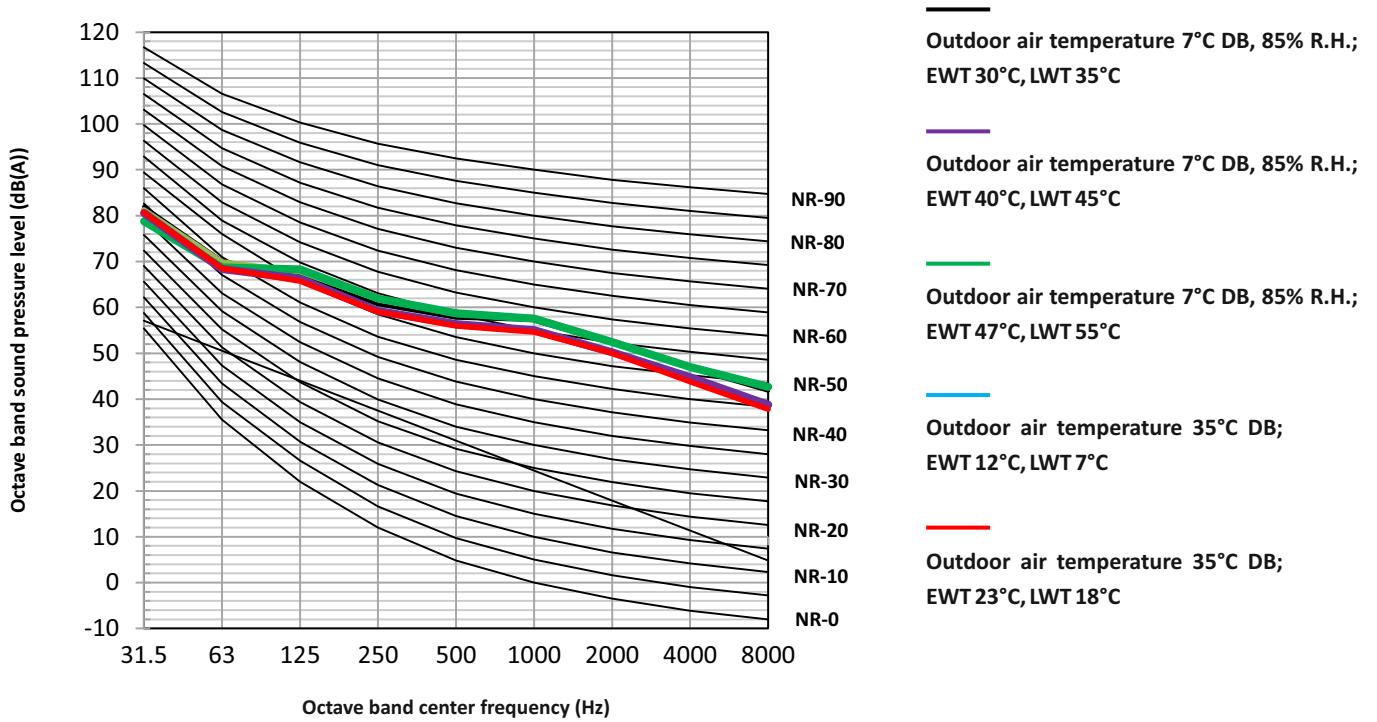
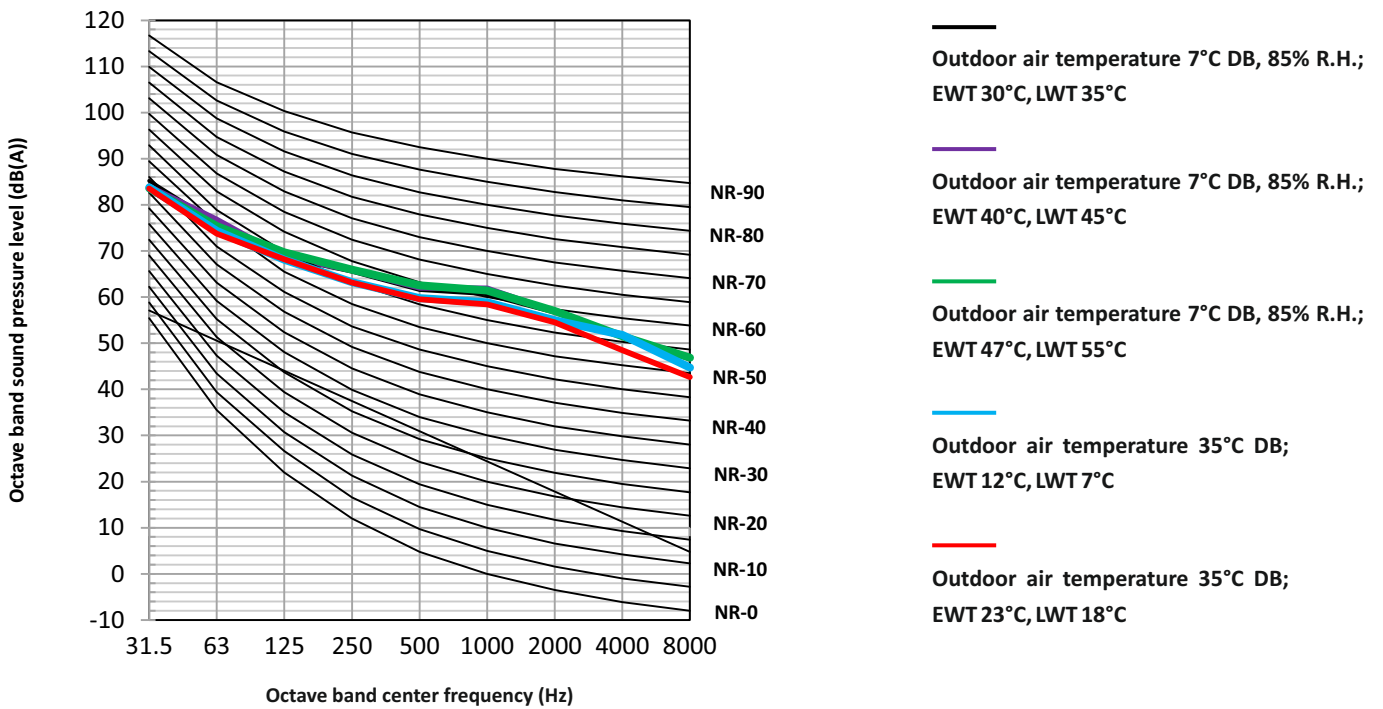





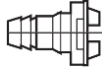

Figure 2-8.3: MHPA30RP24P3CM octave band levels



9 Accessories

9.1 Standard accessories

Table 2-9.1: Standard accessories

Name	Shape	Quantity	Name	Shape	Quantity
Technical manual		1	Tighten belt for customer wiring use		2
Service manual		1	Water outlet connection pipe assembly		2
Y-shaped filter		1	Adapter for inlet water pipe		1

Part 3

Installation and Field Settings

1 Preface to Part 3	22
2 Installation	23
3 Water Pipework	28
4 Electrical Wiring	32
5 DIP Switch Settings	34
6 Internal Circulation Pump Speed Settings	35

1 Preface to Part 3

1.1 Notes for Installers Boxes

The information contained in this Technical manual may primarily be of use during the system design stage of a heat pump Mono project. Additional important information which may primarily be of use during field installation has been placed in boxes, such as the example below, titled “Notes for installers”.

Notes for installers



- Notes for installers boxes contain important information which may primarily be of use during field installation, rather than during desk-based system design.

1.2 Definitions

In this Technical manual, the term “applicable legislation” refers to all national, local and other laws, standards, codes, rules, regulations and other legislation that apply in a given situation.

1.3 Precautions

All system installation including installation of water piping and electrical works must only be carried out by competent and suitably qualified, certified and accredited professionals and in accordance with all applicable legislation.

2 Installation

2.1 Acceptance and Unpacking

Notes for installers



- When units are delivered check whether any damage occurred during shipment. If there is damage to the surface or outside of a unit, submit a written report to the shipping company.
- Check that the model, specifications and quantity of the units delivered are as ordered.
- Check that all accessories ordered have been included. Retain the Technical manual for future reference.

2.2 Hoisting

Notes for installers



- Do not remove any packaging before hoisting. If units are not packaged or if the packaging is damaged, use suitable boards or packing material to protect the units.
- Hoist one unit at a time, using two ropes to ensure stability.

Figure 3-2.1: Hoisting the unit

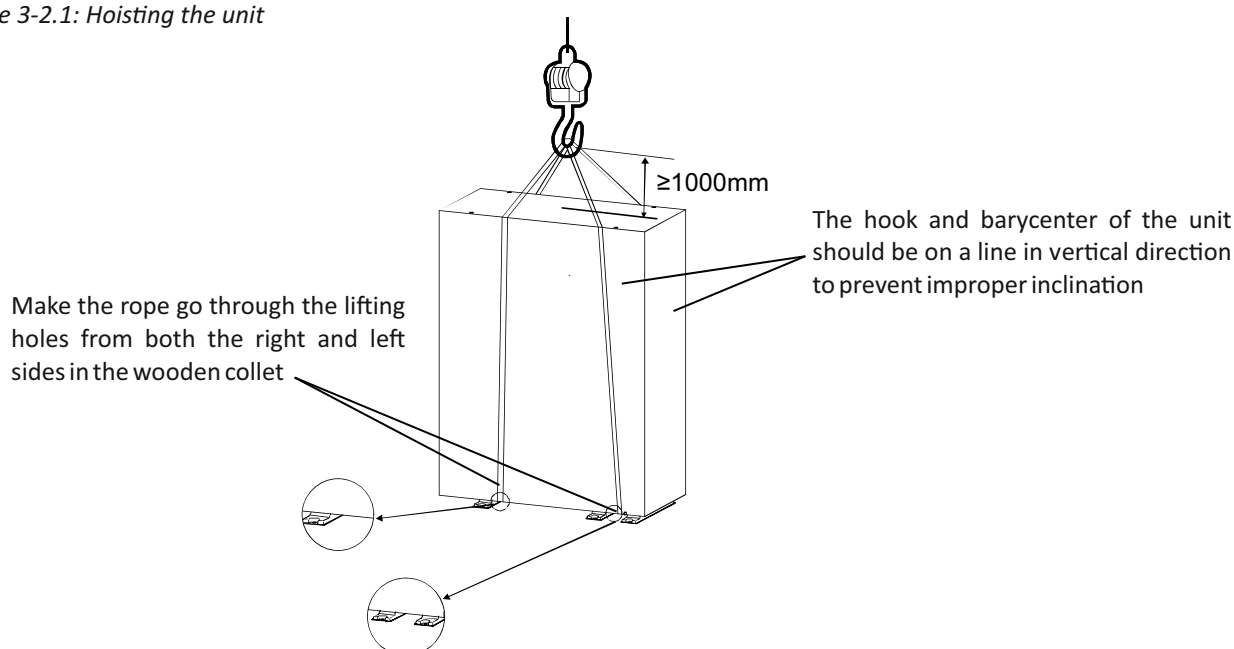

2.3 Placement Considerations

Placement of the outdoor unit should take account of the following considerations:

- Outdoor units should not be exposed to direct radiation from a high-temperature heat source or a potentially explosive atmosphere. Outdoor units should be installed in positions that are as far as possible to the heat emitters.
- Outdoor units should not be installed in positions often used as a work space. In case of construction work (e.g. grinding etc.) where dust or dirt is created and it may affect heat exchangers.
- Outdoor units should not be installed in locations where exposure to oil or to corrosive or harmful gases, such as acidic or alkaline gases, may occur.
- Outdoor units should be installed in well-drained, well-ventilated positions.
- Outdoor units should be installed in positions that are sufficiently close to the desired position of the wired controller that the controller's wiring length limitation will not be exceeded.

- In systems that are configured to heat domestic hot water and/or include an external backup electric heater, outdoor units should be installed in positions that are sufficiently close to the domestic hot water tank and/or backup electric heater that the piping and temperature sensor wiring length come within the allowable ranges.
- Outdoor units should be installed in locations where the noise from the unit will not disturb neighbors.
- Outdoor units should be installed in safe places which can bear the units' weight and vibration and where the unit can be installed at an even level.
- Outdoor units should be installed in positions that there is no possibility of flammable gas or product leak.
- Outdoor unit should be installed in positions where servicing space can be well ensured.
- Outdoor units should be installed in positions where rain can be avoided as much as possible.
- Outdoor units should be installed in clean area in case of small animals making contact with electrical parts, which can cause malfunction, smoke or fire.
- There is flammable refrigerant in the unit and it should be installed in well-ventilated site. If the unit is installed inside, an additional refrigerant detection device and ventilation equipment must be added in accordance with the standard EN378.
- Adequate measures should be adopted to prevent the unit from being used as a shelter by small animals.

2.4 Strong Wind Installation

Wind of 5 m/s or more blowing against an outdoor unit's air outlet blocks the flow of air through the unit, leading to deterioration in unit capacity, accelerated frost accumulation when in heating mode or domestic hot water mode, and potential disruption to operation due to increased pressure in the refrigerant circuit. Exposure to very strong wind can also cause the fan to rotate excessively fast, potentially leading to damage to the fan. In locations where exposure to high winds may occur should take account of the following considerations:

- Set the outlet side at a right angle to the direction of the wind, refer to Figure 3-2.2. For installation of the outdoor unit in a place where the wind direction can be foreseen, refer to Figure 3-2.3 for installation of the unit.
- If turn the air outlet side toward the building's wall, fence or screen. Make sure there is enough room to do the installation.

Figure 3-2.2: Strong wind installation direction

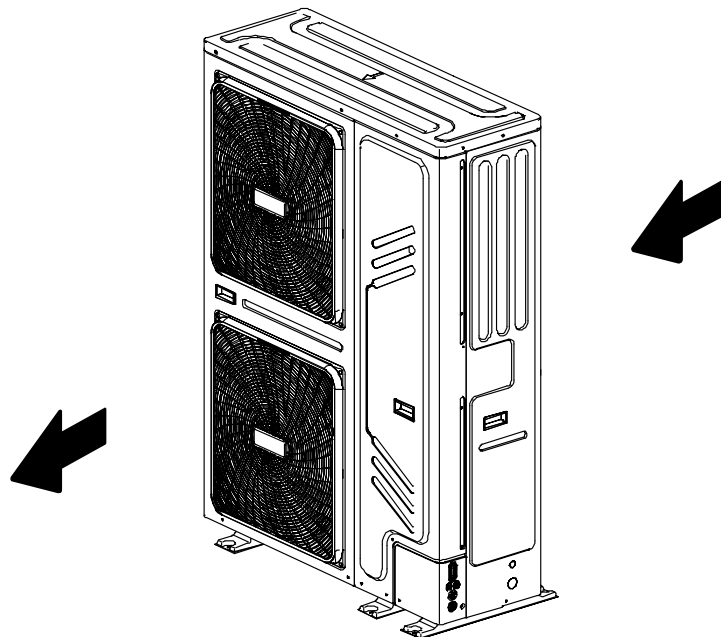
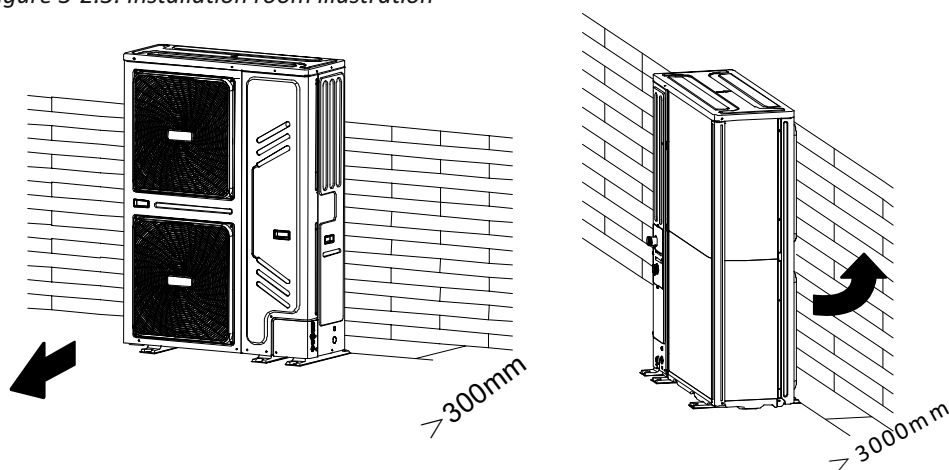

Figure 3-2.3: Installation room illustration



2.5 Cold Climate Installation

In cold climate locations installation should take account of the following considerations:

- Never install the unit at a site where the suction side may be exposed directly to wind.
- To prevent exposure to wind, install a baffle plate on the air discharge side of the unit.
- To prevent exposure to wind, install the unit with its suction side facing the wall.
- In areas of heavy snowfall, a canopy should be installed to prevent snow entering the unit. Additionally, the height of the base structure should be increased so as to raise the unit further off the ground and make sure that the heat exchanger coil is not affected by the snow. Refer to Figure 3-2.4.

Notes:

- Construct a large canopy.
- Construct a pedestal.
- Install the unit high enough off the ground to prevent it from being buried in snow.

Figure 3-2.4: Snow shielding

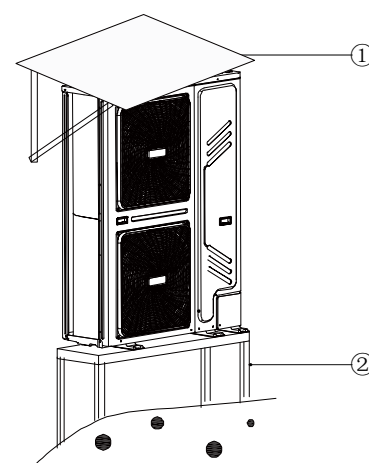

2.6 Hot Climate Installation

As the outdoor temperature is measured via the outdoor ambient temperature sensor, make sure to install the outdoor unit in the shade, or a canopy should be constructed to avoid direct sunlight. So that it is not influenced by the sun's heat, otherwise system protection may occur.

2.7 Base Structure

Outdoor unit base structure design should take account of the following considerations:

- A solid base prevents excess vibrations and noise. Outdoor unit bases should be constructed on solid ground or on structures of sufficient strength to support the unit's weight.
- Bases should be at least 100 mm high to provide sufficient drainage and to prevent water ingress into the base of the unit.
- Either steel or concrete bases may be suitable.
- Outdoor units should not be installed on supporting structures that could be damaged by water build-in in the event of a blocked drain.
- Fix the unit securely to foundation by means of the $\Phi 10$ expansion bolt. It is best to screw in the foundation bolts until their length is 20 mm from the foundation surface.

Figure 3-2.5: Outdoor unit typical concrete base structure design (unit: mm)

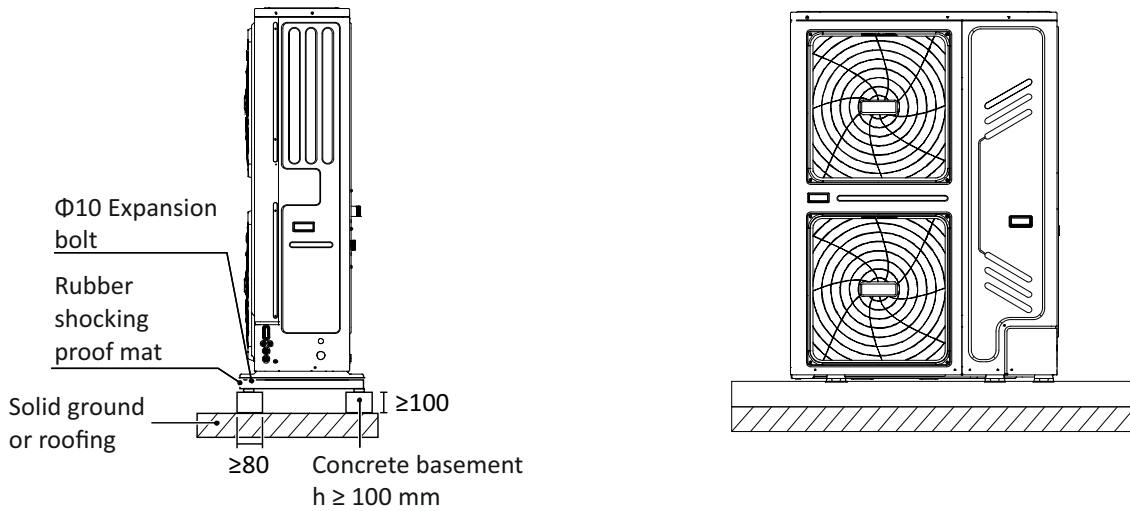

2.8 Drainage

Drainage ditch should be provided to allow drainage of condensate that may form on the the air side heat exchanger when the unit is running in heating mode or domestic hot water mode. The drainage should ensure that condensate is directed away from roadways and footpaths, especially in locations where the climate is such that condensate may freeze.

Figure 3-2.6: Drainage hole

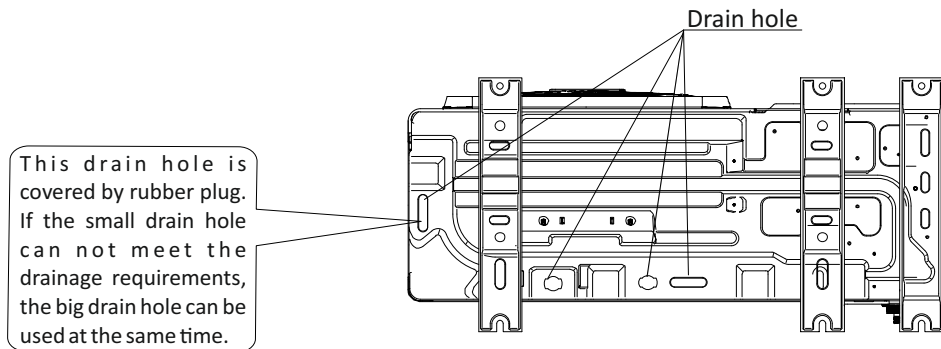

2.9 Spacing

Outdoor units must be spaced such that sufficient air may flow through each unit. Sufficient airflow across heat exchangers is essential for outdoor units to function properly. For more details please refer to the figures below.

Figure 3-2.7: Single unit installation

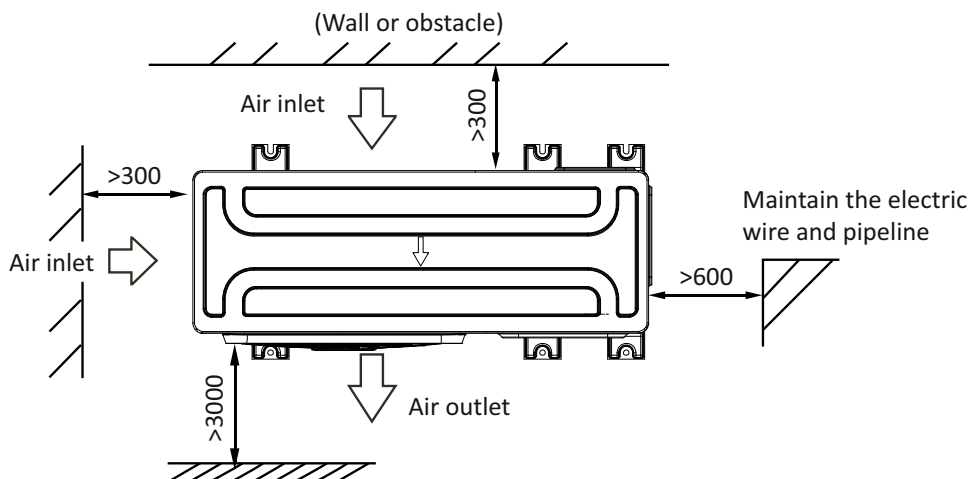

Figure 3-2.8: Parallel connect the two units or more

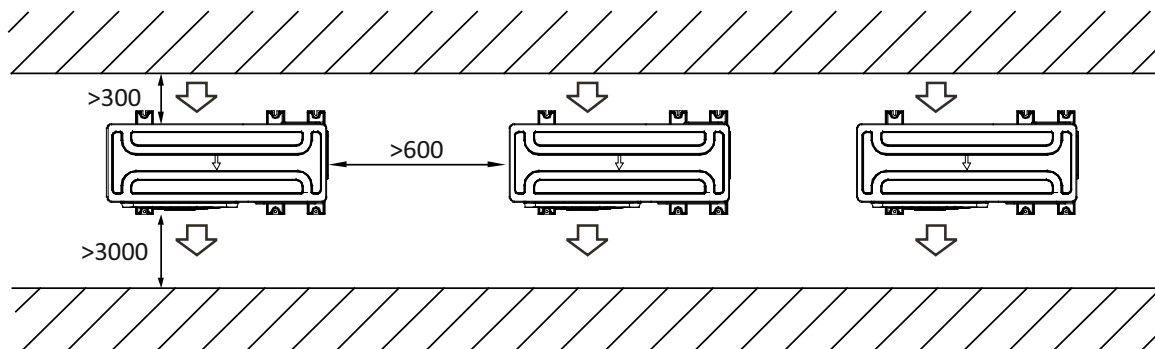
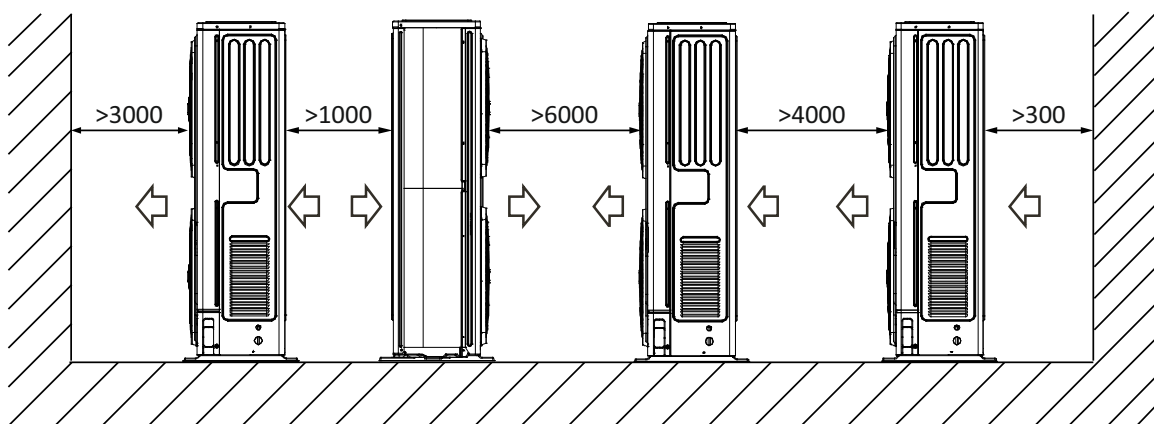

Figure 3-2.9: Parallel connect the front with rear sides



3 Water Pipework

3.1 Water Circuit Checks

Heat pump Mono units are equipped with water inlet and outlet for connection to a water circuit. Heat pump Mono units should only be connected to closed water circuits. Connection to an open water circuit would lead to excessive corrosion of the water piping. Only materials complying with all applicable legislation should be used.

Before continuing installation of the unit, check the following:

- The maximum water pressure ≤ 3 bar.
- The maximum water temperatures $\leq 70^{\circ}\text{C}$ according to safety devices setting.
- Always use materials that are compatible with the water used in the system and with the materials used in the unit.
- Ensure that components installed in the field piping can withstand the water pressure and temperature.
- Drain taps must be provided at a low points of the system to permit complete drainage of the circuit during maintenance.
- Air vents must be provided at all high points of the system. The vents should be located at points that are easily accessible for service. An automatic air purge is provided inside the unit. Check that this air purge valve is not tightened so that automatic release of air in the water circuit is possible.

3.2 Water Volume and Expansion Vessel Pre-pressure Checks

Outdoor units are equipped with an expansion vessel (8L) that has a default pre-pressure of 1.0 bar. To assure proper operation of the unit, the pre-pressure of the expansion vessel might need to be adjusted.

Table 3-3.1: Expansion vessel pre-pressure adjustment

Installation height difference ¹	Water volume $\leq 230\text{L}$	Water volume $> 230\text{L}$
≤ 7 m	No pre-pressure adjustment required.	Actions required: <ul style="list-style-type: none"> • Pre-pressure must be decreased, calculate according to "Calculating the pre-pressure of the expansion vessel"²; • Check if the water volume is lower than maximum allowed water volume (refer to Figure 3-3.1).
> 7 m	Actions required: <ul style="list-style-type: none"> • Pre-pressure must be increased, calculate according to "Calculating the pre-pressure of the expansion vessel"²; • Check if the water volume is lower than maximum allowed water volume (refer to Figure 3-3.1). 	Expansion vessel in the outdoor unit is too small for the system. An external expansion vessel (field supplied) is required.

Notes:

1. Height difference is between the highest point of the water circuit and the outdoor unit's expansion tank. Unless the unit is located at the highest point of the system, in which case the installation height difference is considered to be zero.

2. Calculating the pre-pressure of the expansion vessel:

The pre-pressure (P_g) to be set depends on the maximum installation height difference (H) and is calculated as $P_g(\text{bar}) = (H(\text{m})/10+0.3)$ bar.

To determine the maximum allowed water volume in the entire circuit, proceed as follows:

- Determine the calculated pre-pressure (P_g) for the corresponding maximum water volume using the Figure 3-3.1.

Figure 3-3.1: Maximum water volume

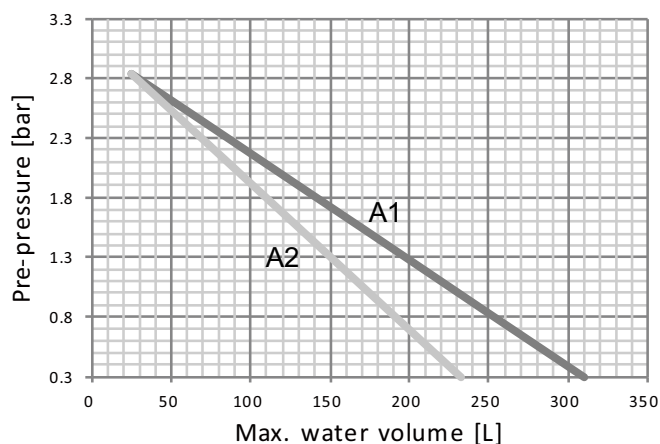

A1: System without glycol

A2: System with 25% propylene glycol

Pre-pressure = pre-pressure of the expansion vessel

Maximum water volume = maximum water volume in the system

- Check that the total water volume in the entire water circuit is lower than this value. If this is not the case, the expansion vessel inside the unit is too small for the installation.

Example 1:

The unit is installed 5m below the highest point in the water circuit. The total water volume in the water circuit is 100L. In this example, no action or adjustment is required.

Example 2:

The unit is installed at the highest point in the water circuit. The total water volume in the water circuit is 250L.

Result:

- Since 250L is more than 230L, the pre-pressure must be decreased.
- The required pre-pressure is: $P_g \text{ (bar)} = (H(m)/10 + 0.3) \text{ bar} = (0/10 + 0.3) \text{ bar} = 0.3 \text{ bar}$.
- The corresponding maximum water volume can be read from the graph: approximately 310L.
- Since the total water volume (250L) is below the maximum water volume (310L), the expansion vessel suffices for the installation.

When it is required to change the default pre-pressure of the expansion vessel (1.0 bars), following guidelines:

- Use only dry nitrogen to set the expansion vessel pre-pressure.
- Inappropriate setting of the expansion vessel pre-pressure will lead to malfunctioning of the system. Pre-pressure should only be adjusted by a licensed installer.

If the expansion vessel of unit is too small for the installation, an additional expansion vessel is needed.

- Calculate the pre-pressure of the expansion vessel: $P_g \text{ (bar)} = (H(m)/10 + 0.3) \text{ bar}$
The expansion vessel equipped in the unit should adjust the pre-pressure also.
- Calculate the volume needed of the additional expansion vessel: $V1 = 0.0693 * V_{\text{water}} / (2.5 - P_g) - V0$
 V_{water} : the volume of the water in the system
 $V0$: the volume of expansion vessel which the unit is equipped (8L).

3.3 Water Circuit Connection

Water connections must be made correctly in accordance with the labels on the outdoor unit, with respect to the water inlet and water outlet. If air, moisture or dust gets in the water circuit, problems may occur. Therefore, always take into account the following when connecting the water circuit:

- Use clean pipes only.
- Hold the pipe end downwards when removing burrs.
- Cover the pipe end when inserting it through a wall to prevent dust and dirt entering.

- Use a good thread sealant for sealing the connections. The sealing must be able to withstand the pressures and temperatures of the system.
- When using non-copper metallic piping, be sure to insulate the two kind of materials from each other to prevent galvanic corrosion.
- For copper is a soft material, use appropriate tools for connecting the water circuit. Inappropriate tools will cause damage to the pipes.

3.4 Water Circuit Anti-freeze Protection

Ice formation can cause damage to the hydronic system. As the outdoor unit may be exposed to sub-zero temperatures, care must be taken to prevent freezing of the system. All internal hydronic parts are insulated to reduce heat loss. Insulation must also be added to the field piping.

- The software contains special functions using heat pump to protect the entire system against freezing.
When the temperature of the water flow in the system drops to a certain value, the unit will heat the water, either using the heat pump, the electric heating tap, or the backup heater. The freeze protection function will turn off only when the temperature increases to a certain value.
- In event of power failure, the above features would not protect the unit from freezing.
Since a power failure could happen when the unit is unattended, the supplier recommends use anti-freeze fluid to the water system or install freeze protection valves which can drain the water from the system before it can freeze.
- Anti-freeze fluid:

Depending on the expected lowest outdoor temperature, make sure the water system is filled with a concentration of glycol as mentioned in the table below. If the system contains a domestic hot water tank, then only propylene glycol is suitable. If the system does NOT contain domestic hot water tank, then either propylene glycol or ethylene glycol is OK. When glycol is added to the system, the performance of the unit will be affected. The correction factor of the unit capacity, flow rate and pressure drop of the system is listed in the table 3-3.2 and 3-3.3.

Table 3-3.2: Ethylene Glycol

Concentration of ethylene glycol (%)	Modification coefficient				Minimum outdoor temperature (°C)
	Cooling capacity modification	Power modification	Water resistance	Water flow modification	
0	1.000	1.000	1.000	1.000	0
10	0.984	0.998	1.118	1.019	-5
20	0.973	0.995	1.268	1.051	-15
30	0.965	0.992	1.482	1.092	-25

Table 3-3.3: Propylene Glycol (including the necessary inhibitors, classified as Category III according to EN1717)

Concentration of propylene glycol (%)	Modification coefficient				Minimum outdoor temperature (°C)
	Cooling capacity modification	Power modification	Water resistance	Water flow modification	
0	1.000	1.000	1.000	1.000	0
10	0.976	0.996	1.071	1.000	-4
20	0.961	0.992	1.189	1.016	-12
30	0.948	0.988	1.380	1.034	-20

Uninhibited glycol will turn acidic under the influence of oxygen. This process is accelerated by presence of copper and at higher temperatures. The acidic uninhibited glycol attacks metal surfaces and forms galvanic corrosion cells that cause severe damage to the system. It is of extreme importance:

- That the water treatment is correctly executed by a qualified water specialist.

- That a glycol with corrosion inhibitors is selected to counteract acids formed by the oxidation of glycols.
 - That in case of an installation with domestic hot water tank, only the use of propylene glycol is allowed. In other installations the use of ethylene glycol is fine.
 - That no automotive glycol is used because their corrosion inhibitors have a limited lifetime and contain silicates that can foul or plug the system.
 - That galvanized piping is not used in glycol system since it may lead to the precipitation of certain elements in the glycol's corrosion inhibitor.
 - To ensure that the glycol is compatible with the materials used in the system.
- Freeze protection by freeze protection valves:
When no glycol is added to the water, freeze protection valves can be used to drain the water from the system before it can freeze.
- Install freeze protection valves (field supply) at all lowest points of the field piping.
 - Normally closed valves (located indoors near the piping entry/exit points) can prevent that all water from indoor piping is drained when the freeze protection valves open.

3.5 Water Flow Switch

Water may enter into the flow switch and cannot be drained out and may freeze when the temperature is low enough. The flow switch should be removed and dried, then can be reinstalled in the unit.

- Counterclockwise rotation, remove the water flow switch.
- Drying the water flow switch completely.

Figure 3-3.2: Water flow switch

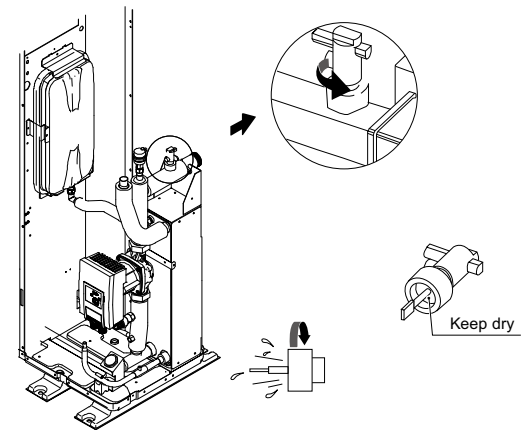

3.6 Adding Water

- Connect the water supply to the fill valve and open the valve.
- Make sure the automatic air purge valve is open (at least 2 turns). Refer to Figure 3-3.3.
- Fill with water until the manometer indicates a pressure of approximately 2.0 bars. Remove air in the circuit as much as possible using the air purge valve. Air in the water circuit could lead to malfunction of the backup electric heater.

Figure 3-3.3: Air purge valve

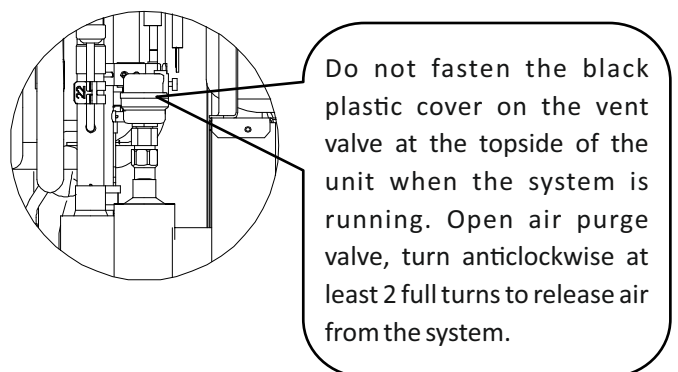

3.7 Water Piping Insulation

The complete water circuit including all piping, water piping must be insulated to prevent condensation during cooling operation and reduction of the heating and cooling capacity as well as prevention of freezing of the outside water piping during winter. The insulation material should be at least of B1 fire resistance rating and complies with all applicable legislation. The thickness of the sealing materials must be at least 13 mm with thermal conductivity 0.039 W/mK in order to prevent freezing on the outside water piping. If the outdoor ambient temperature is higher than 30°C and the humidity is higher than RH 80%, the thickness of the sealing materials should be at least 20 mm in order to avoid condensation on the surface of the seal.

4 Electrical Wiring

4.1 General

Notes for installers



Caution

- All installation and wiring must be carried out by competent and suitably qualified, certified and accredited professionals and in accordance with all applicable legislation.
- Electrical systems should be grounded in accordance with all applicable legislation.
- Overcurrent circuit breakers and residual-current circuit breakers (ground fault circuit interrupters) should be used in accordance with all applicable legislation.
- Wiring patterns shown in this data book are general connection guides only and are not intended for, or to include all details for any specific installation.
- The water piping, power wiring and communication wiring are typically run in parallel. However the communication wiring should not be bound together with power wiring. To prevent signal interference, the power wiring and communication wiring should not be run in the same conduit. If the power supply is less than 10A, a separation of at least 300 mm between power wiring and communication wiring conduits should be maintained; if the power supply is in the range 10A to 50A then a separation of at least 500 mm should be maintained.

4.2 Precautions

- Fix cables so that cables do not make contact with the pipes (especially on the high pressure side).
- Secure the electrical wiring with cable ties, so that it does not come in contact with the piping, particularly on the high-pressure side.

Figure 3-4.1: Wiring hole locations

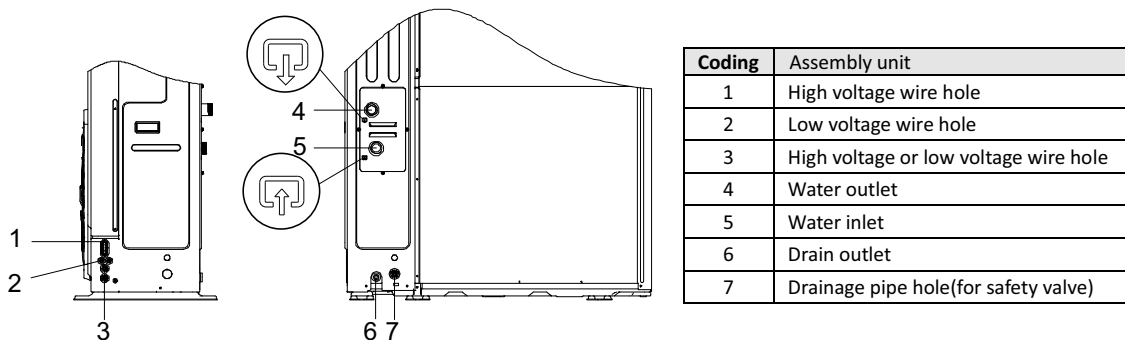

- Make sure no external pressure is applied to the terminal connectors.
- When installing the ground fault circuit interrupter make sure that it is compatible with the inverter (resistant to high frequency electrical noise) to avoid unnecessary opening of the ground fault circuit interrupter.
- This unit is equipped with an inverter. Installing a phase advancing capacitor not only reduce the power factor improvement effect, but also may cause abnormal heating of the capacitor due to high frequency waves. Never install a phase advancing capacitor as it could lead to an accident.

4.3 Guidance

- Most field wiring on the unit is to be made on the terminal block inside the switch box. To gain access to the terminal block, remove the switch box service panel.
- Fix all cables using cable ties.

- A dedicated power circuit is required for the backup electric heater.
- Installation equipped with a domestic hot water tank (field supplied) requires a dedicated power circuit for the immersion heater.
- Lay out the electrical wiring so that the front cover does not rise up when doing wiring work and attach the front cover securely.
- Follow the electric wiring diagrams for electrical wiring works. Refer to Figure 2-4.1 in part 2, 4 "Wiring Diagram".
- Install the wires and fix the cover firmly so that the cover may be fit in properly.

5 DIP Switch Settings

DIP switch is located on the hydraulic module main control board and allows configuration of additional heating source thermistor installation, the second inner backup heater installation, etc.

Table 3-5.1: DIP switch settings

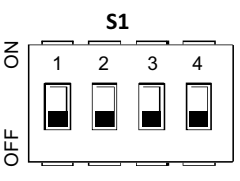
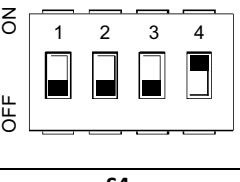
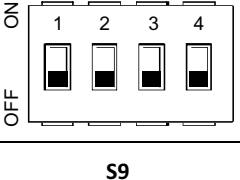
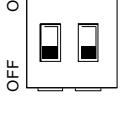
Switch		ON=1	OFF=0	Default factory setting
 <p>S1</p>	1	Reserved	Reserved	OFF
	2	Reserved	Reserved	OFF
	3/4	0/0 = Without IBH and AHS 1/0 = With IBH 0/1 = With AHS for heat mode 1/1 = With AHS for heat mode and DHW mode		OFF/OFF
 <p>S2</p>	1	Start Pump_o after six hours will be invalid	Start Pump_o after six hours will be valid	OFF
	2	without TBH	with TBH	OFF
	3/4	0/0 = variable speed pump (Max head: 8.5 m) 0/1 = constant speed pump 1/0 = variable speed pump (Max head: 10.5 m) 1/1 = variable speed pump (Max head: 9 m)		OFF/ON
 <p>S4</p>	1/2/3/4	Reserved		OFF
				OFF
				OFF/OFF
 <p>S9</p>	1/2	0/0 = Slave unit 1/1 = Master unit		OFF

6 Internal Circulation Pump Speed Settings

The internal circulation pump speed can be selected by adjusting the red knob on the pump. The default factory setting is the highest speed (III). If the system water flow is too high, the pump speed can be set to medium (II) or low (I). The relationship between external static pressure and water flow rate is described in Part 2, 7 "Hydronic Performance".

Figure 3-6.1: Internal circulation pump

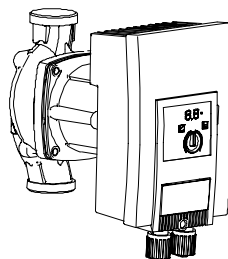

Table 3-6.1: Faults with external interference sources

Faults	Causes	Remedy
Pump is not running although the power supply is switched on. Black display.	Electrical fuse defective.	Check fuses.
	Pump has no voltage.	Restore power after interruption.
Pump is making noises.	Cavitation due to insufficient suction pressure.	Increase the system suction pressure within the permissible range.
		Check the delivery head setting and set to lower head if necessary.

▪ Fault signals:

- The fault signal is indicated by the LED display.
- The fault signal LED is continuously illuminated in red.
- The pump switches off (depending on the error code), and attempts a cyclical restart. (Specially, for Error code E10 (blocking): After approx. 10 minutes, the pump switches off permanently and displays the error code.)

Table 3-6.2: Fault signals

Code No.	Fault	Cause	Remedy
E04	Mains undervoltage	Power supply too low on mains side.	Check mains voltage.
E05	Mains overvoltage	Power supply too high on mains side.	Check mains voltage.
E09	Turbine operation	The pump is driven in reverse (the fluid flows through the pump from the pressure to the suction side).	Check flow, install non-return valves if necessary.
E10	Blocking	The rotor is blocked.	Request customer service.
E21*	Overload	Sluggish motor.	Request customer service.
E23	Short-circuit	Motor current too high.	Request customer service.
E25	Contacting / winding	Motor winding defective.	Request customer service.
E30	Module overheated	Module interior too warm.	Improve room ventilation, check operating conditions, request customer service, if necessary
E31	Overheated power section	Ambient temperature too high	Improve room ventilation, check operating conditions, request customer service, if necessary.
E36	Electronic faults	Electronics defective.	Request customer service.

* In addition to the LED display, the fault signal LED is continuously illuminated in red.

- Warning signals:
 - The warning signal is indicated by the LED display.
 - The fault signal LED and the SSM relay do not respond.
 - The pump continues to run with limited output.
 - The indicated faulty operating status must not occur for a prolonged period. The cause must be eliminated.

Figure 3-6.4: Warning signals

Code No.	Fault	Cause	Remedy
E07	Generator operation	Pump hydraulics have fluid running through them.	Check the system.
E11	Dry running	Air in the pump.	Check the water volume / pressure.
E21*	Overload	Sluggish motor, pump is operated outside of its specifications (e.g. high module temperature). The speed is lower than during normal operation.	Check the ambient conditions.

* In addition to the LED display, the fault signal LED is continuously illuminated in red.

- In order to ensure the service life of the pump, it is recommended that the unit run at least once every 2 weeks (ensure that the pump is running) or keep it powered on for a long time (in the power-on standby state, the unit will run the pump for 3 minutes every 6 hours).



Company assumes no responsibility for possible inaccuracies in this book originated typographical errors or rewriting. All the pictures and diagrams are principal and it is necessary to adjust each actual situation on the field, in any case the company reserves the right to enter their own products such modifications as considered necessary.

Centrometal d.o.o. Glavna 12, 40306 Macinec, Croatia

central tel: +385 40 372 600, fax: +385 40 372 611
service tel: +385 40 372 622, fax: +385 40 372 621

www.centrometal.hr
e-mail: servis@centrometal.hr

Centrometal
HEATING TECHNIQUE
