

Centrometal

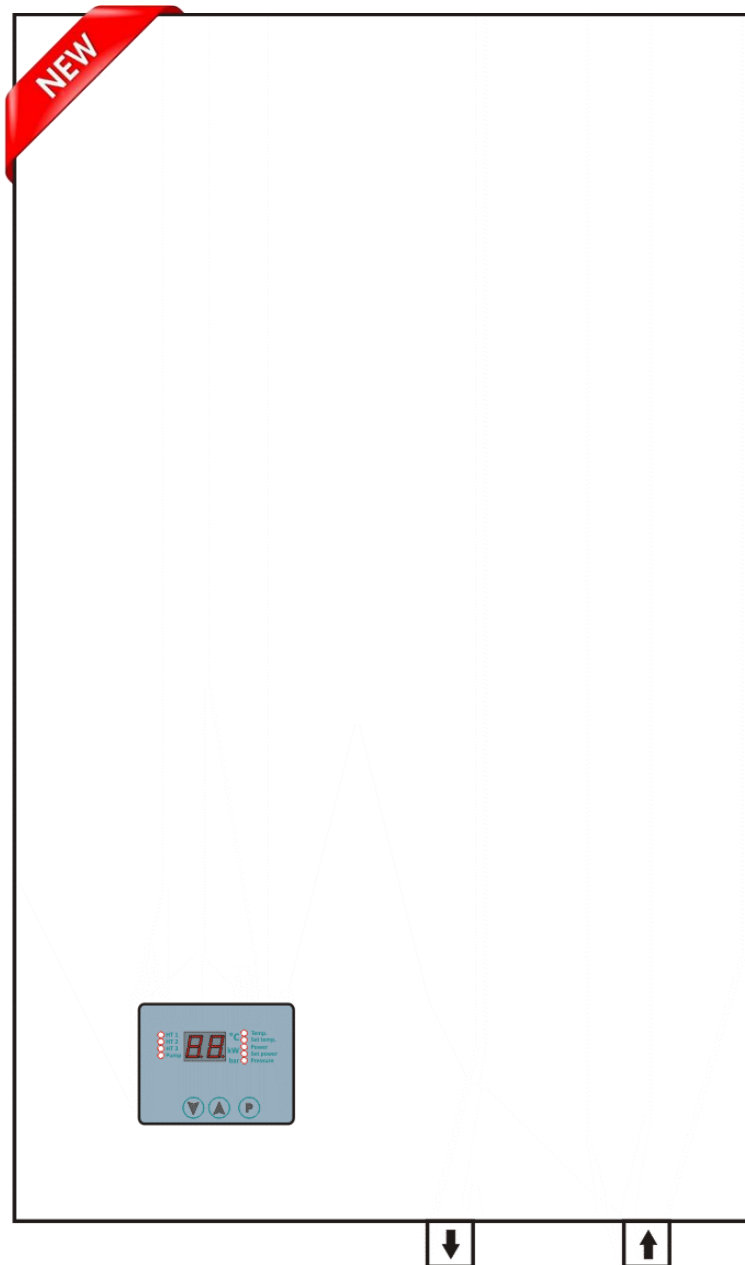

Guidebook for installation, handling and maintenance – ENG

El-Cm Classic

Electric block-boiler for heating systems with thermoregulatory microprocessor

Content

1. Description of symbols and instructions for safe work

2. Device data

- 2.1 Typology
 - 2.1.1 Statement on compliance
 - 2.1.2 Regular application
- 2.2 Instructions for mounting
- 2.3 Instructions for work
- 2.4 Anti-frost protection and inhibitors
- 2.5 Norms, regulations and standards
- 2.6 Tools, materials and auxiliary measures
- 2.7 Minimum distances and Inflammability of construction materials
- 2.8 Product description
- 2.9 Waste disposal
- 2.10 Scope of delivery
- 2.11 Factory data plate
- 2.12 Dimensions and technical data
 - 2.12.1 Dimensions and technical data for boiler EI-Cm Classic
 - 2.12.2 Technical data

3. Transportation

4. Device installing

- 4.1 Warnings before mounting
- 4.2 Distances
- 4.3 De-mounting of front casing
- 4.4 Boiler mounting
- 4.5 Hydraulic connections testing
- 4.6 Systems on which the Boiler can be connected
- 4.7 Installation filling with water and waterproof testing
 - 4.7.1 Filling the boiler with water and testing sealing
 - 4.7.2 Heating pump air emission and de-blocking
 - 4.7.3 Boiler and installation air emission

5. Electrical connection

- 5.1 Positions of introducer for the introduction of the power cable
- 5.2 Connecting power (voltage) cable
- 5.3 Scheme for connecting power (voltage) cable
- 5.4 Connect boiler's external control (room thermostat)
- 5.5 Electrical schemes

6. Commissioning

- 6.1 Before commissioning
- 6.2 First start
- 6.3 Start-up log

7. Handling heating installation

- 7.1 Instruction for work
- 7.2 Overview of the elements to adjust
 - 7.2.1 Device functions
 - 7.2.2 Basic settings
- 7.3 Regulation of heating
 - 7.3.1 Boiler temperature adjustment
 - 7.3.2 Boiler power adjustment
 - 7.3.3 Warnings for pressure
 - 7.3.4 Warnings for low temperature
 - 7.3.5 Warnings for high temperature
 - 7.3.6 Warning symbols and codes
 - 7.3.7 Room temperature thermostat
 - 7.3.8 Interruption of heating
- 7.4 Putting the boiler out of drive

8. Cleaning and maintenance

- 8.1 Boiler heating
- 8.2 Check the working pressure; add the water and air-vent installations
- 8.3 Add the water and vent installation
- 8.4 Inspection and maintenance log

9. Environment protection / Waste disposal

10. Troubles and troubleshooting

11. Instruction for projecting

- 11.1 Pump Wilo-Para MSL/6-43/SC
- 11.2 Pump WILO MSL 12/5 oem 3P
- 11.3 Pump Mikoterm GPA15-7.5 III Pro Z178

12. Product data sheet (in accordance with EU regulation no. 811/2013)

1. Description of symbols and instructions for safe work

1.1 Description of symbols

Warnings

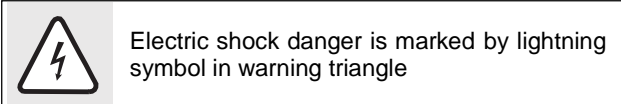
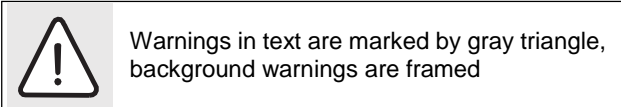

The signal words at the beginning of the warning mean the way and level of consequences if protective measures are not applied

- **NOTE** means that smaller material damages may occur
- **CAUTION** means that smaller to middle injuries may occur
- **WARNING** means that heavy injuries may occur
- **DANGER** means that heavy injuries may occur

Important information



Important information, meaning no danger for people and things, are marked by the symbol displayed in the following text. These are limited by lines, above and below the text

Further symbols

Symbol	Meaning
▶	Action step
→	Directives to other places in document or to other documents
•	Enumeration/Entry from the list
–	Enumeration/Entry from the list (2.)

Table 1

1.2 Instructions for safe work

General safety instructions

Non-compliance with safety instructions may cause heavy injuries – or lethal outcomes and material damages and environment pollution.

- Electrical installation should be examined by an expert prior to the device assembly.
- All electric works should be performed by authorised person in accordance with corresponding regulations.
- Commissioning and maintenance and repairs should be done by authorised service only.
- Technical acceptance of installations should be performed in accordance with corresponding regulations.

Danger because of disrespecting security rules in alert situations, for example fire.

- Never expose your-self to life danger. Own security always has priority.

Damage occurred because of wrong handling

Wrong handling may lead to injuries of persons and/or installation damage.

- Make sure that device is available only to professionals.
- Installation and commissioning, and maintenance and repair, must be done only by service authorised for electrical works.

Installation and commissioning

- Placement of device can be done only by authorised service.
- Boiler can be turned on only if installation is with corresponding pressure level and working pressure regular. Do not close security valves in order to avoid damage caused by too high pressure. During warming water can leak on security valve of the hot water circuit and hot water pipes.
- Install this device only in the room where freezing is not possible to occur.
- Do not store or dispose inflammable materials or liquids in the vicinity of this device.
- Keep safe distance in accordance with valid regulations.

Life threat of electric power shock

- Secure electric power connecting is done by authorised service! Comply with connecting scheme
- Prior to any work: turn off electric power supply. Secure against accidental turn on
- Do not mount this device in moist rooms

Control examination / Maintenance

- Recommendation for user: conclude agreement on maintenance with authorised service to perform annual maintenance and controlling examinations
- User is responsible for safety and environmental acceptance of the installation
- Comply with safety work instruction as given in the chapter *Cleaning and Maintenance*

Authentic spare parts

There shall not be undertaken any responsibility for damage occurred due to spare parts not delivered by the manufacturer

- Use only original spare parts

Material damages due to freezing

- When there is damage due to freezing drain water from the boiler, tank and pipelines for heating. Danger of freezing does not exist only when entire installation is dry

Instructions for service

- Inform users about mode of work of device and instruct them in maintenance
- Inform users not to perform any modifications or repair on their own
- Warn users that children cannot stay near heating installations
- Fill in and submit Commissioning log and Handover log attached in this document
- Deliver technical documentation to the user

Waste disposal

- Dispose packaging materials in ecologically Acceptable manner
- Secure device in ecologically acceptable manner and in authorised place

Cleaning

- Clean outside of device with wet cloth

Dirt catcher 3/4"

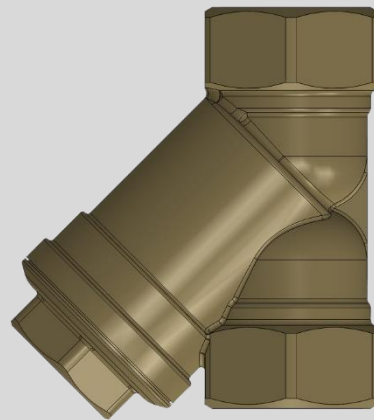

Be sure to install an dirt catcher on the return line.

- **A mechanical failure of the pump that occurs within the warranty period will not be warranted unless an dirt catcher is installed.**
- The dirt catcher should be installed before the boiler is put into operation for the first time.
- Depending on the degree of soiling of the installation, the dirt catcher needs to be cleaned periodically.

2. Device data

These instructions contain important information about safe and professional assembly, commissioning and maintenance of the boiler.

These instructions are for installers who have knowledge for work with heating installations due to their professionalism and experience.

2.1 Typology

These instructions are related to the following kind of device:

El-Cm Classic	4,5 - 27 kW
----------------------	-------------

2.1.1 Statement on compliances

We hereby state that devices are tested in accordance with the following directives: 2014/35/EU (low voltage directive, LVD) and 2014/30/EU (electro-magnetic compatibility directive, EMC).

2.1.2 Regular application

The boiler can be used only for heating the water for heating system and for indirect use of hot water. To ensure correct use it is mandatory to comply with instructions for handling, data on the factory plate and technical data.

2.2 Instructions for mounting



Use only original spare parts of the manufacturer or spare parts approved by the manufacturer. There shall not be any responsibility for damages caused by spare parts which have not been delivered by the manufacturer

When mounting heating installations keep with the following instructions:

- Valid regulations in construction industry
- Regulations and norms on safety-technical equipment of heating installations
- Changes on the place of mounting according to valid regulations propisima

2.3 Instructions for work

When working with heating installation follow next instructions:

- ▶ Boiler should work in working range up to max temperature of 80°C and min pressure of 0.7 bars to max pressure of 2.6 bars, which should be controlled on regular basis
- ▶ Boiler should be handled only by adults who are familiar with instructions and work of the boiler
- ▶ Do not close safety valve
- ▶ Inflammatory objects must not be put on the boiler surface or close to it (within safety distance)
- ▶ Boiler surface clean only with non-inflammatory products
- ▶ Inflammatory substances do not keep in the room for boiler installation (e.g. petroleum, oil, etc.)
- ▶ During the work no one lid must be open
- ▶ Keep safe distance in accordance with regulations

2.4 Inhibitors and anti-frost products

It is not allowed to use protective products against frost neither inhibitors. If it is not possible to avoid anti-frost protection then should use anti-frost products allowed for heating installations.



Anti-frost products:

- ▶ Reduce lifetime of the boiler and its parts
- ▶ Reduce heat transmission

2.5 Norms, regulations and standards

The product is in compliance with the following norms and regulations:

- EN 50110-1:2013 – Operation of electrical installations - Part 1: General requirements
- EN 55014-1:2017; EN 55014-2:2015 – Electromagnetic compatibility - Requirements for household appliances, electric tools and similar apparatus - Part 1: Emission - Part 2: Immunity - Product family standard
- EN 60335-1:2016 Household and similar electrical appliances - Safety - Part 1: General requirements
- EN 61000-3-2:2019 Electromagnetic compatibility (EMC) - Part 3-2: Limits - Limits for harmonic current emissions
- EN 61000-3-3:2014/A1:2020 Electromagnetic compatibility (EMC) - Part 3-3: Limits - Limitation of voltage changes, voltage fluctuations and flicker in public low-voltage supply systems

2.6 Tools, materials and auxiliary measures

Standard tools for heating installations, water supply and electric-installations are needed for mounting and maintenance of the boiler.

2.7 Minimum distances and burnable construction materials

Depending on valid regulations, other minimum distances could be applied, different than mentioned below.

- ▶ Comply with regulations of electrical installations and minimum distances which are in force in the subject country
- ▶ Minimum distance for heavy inflammable and self-extinguishing materials is 200 mm

Inflammability of components		
A	Non-inflammable	
A1:	Non-inflammable	Asbestos, stone, wall tiles, baked clay, plaster (with no organic additives)
A2:	With smaller quantity of added elements (organic components)	Plaster cardboards plates, base felt, glass fibres, plates of ACUMIN, ISOMIN, RAIOT, LOGNOS, VELOX, AND HERACLITUS
B	Inflammable	
B1:	Hardly inflammable	Beech, oak, veneered wood, felt, HOBREX, VERSALIT and UMAKART plates
B2:	Normally inflammable	Pine, larch and spruce, veneered wood
B3:	Inflammable	Asphalt, cardboard, cellulose materials, tar-paper, plywood plates, cork plates, polyurethane, polystyrene, polyethylene, floor fibre materials

Table 2: Ignitable materials and composition of elements according to DIN 4102

2.8 Product description

Basic components of boiler:

- Boiler body
- Device frame and casing
- Control unit
- Pump
- Expansion dish (per capacity)
- Processor board and boiler electronics
- Water pressure sensor
- Safety valve

Boiler can be installed as integral part of the central heating system, floor heating, hybrid, or accumulation systems.

Boiler is compounded of weld housing of steel tin with thermal insulation. The boiler is fixed on the wall by supplied mounting set. Installed heating insulation in boiler jacket reduces loss of the heat, and also protects against noise.

Safety elements (vent valve, managing surface fuse and temperature safety limitation) are mounted at the top of boiler.

Depending on the type of the boiler, different elements of heating are used. Heating elements' performance can be adjusted according to grades.

Different performance grades sets can be obtained through control panel. Number and division of performance grades are visible from technical data (see chapter 2.12.2).

- | | | | |
|-------|--------------------------------------|----|---------------------------------|
| 1 IN | Return boiler's line | 12 | Terminal for room thermostat |
| 2 OUT | Start boiler's line | 13 | Microprocessor plate |
| 3 | Boiler's exchanger | 14 | Electric heaters contacts |
| 4 | Electric heaters | 15 | Temperature sensor |
| 5 | Expansion dish | 16 | Safety thermostat (STB) |
| 6 | Circulating pump | 17 | Control panel with display |
| 7 | Vent valve (on pump) | 18 | Flexible hose of expansion dish |
| 8 | Safety valve (on pump) | 19 | Drainage hose of air vent |
| 9 | Drain faucet | 20 | Power switch (ON/OFF) |
| 10 | Automatic air vent | 21 | Electric cable access sleeve |
| 11 | Automatic fuses with voltage trigger | 22 | Drainage hose of safety valve |

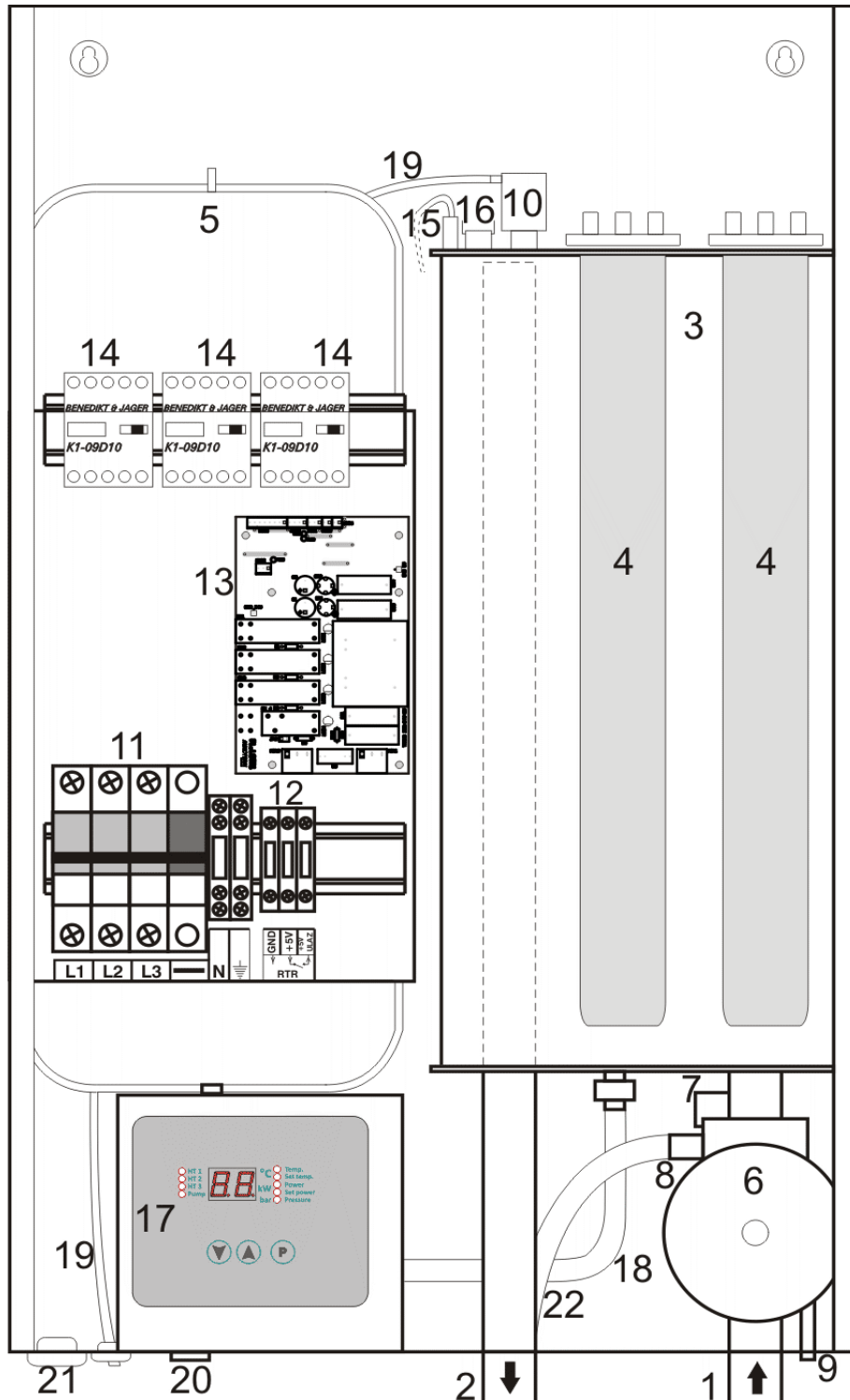

Image 1: Open device view

2.9 Waste disposal

- ▶ Dispose packaging materials in ecologically sound manner
- ▶ Components that should be changed dispose in ecologically sound manner

2.10 Delivery scope

When delivery the boiler stick to the following:

- ▶ Check if packaging is damaged during delivery
- ▶ Check if delivery is complete

Part	Pieces
Boiler EI-Cm Classic	1
Assembly Set	1
Instructions for handling	1

2.11 Factory plate

Factory data plate is placed on the external side of the boiler and contains the following technical data:

- Boiler type
 - Batch / Catalogue number
 - Power
 - Input power
 - Maximum temperature
 - Working pressure
 - Water volume
 - Mass
 - Electric power supply
 - Protection grade
 - Manufacturer
-

2.12 Dimensions and technical data

2.12.1 Dimensions and technical data for boiler

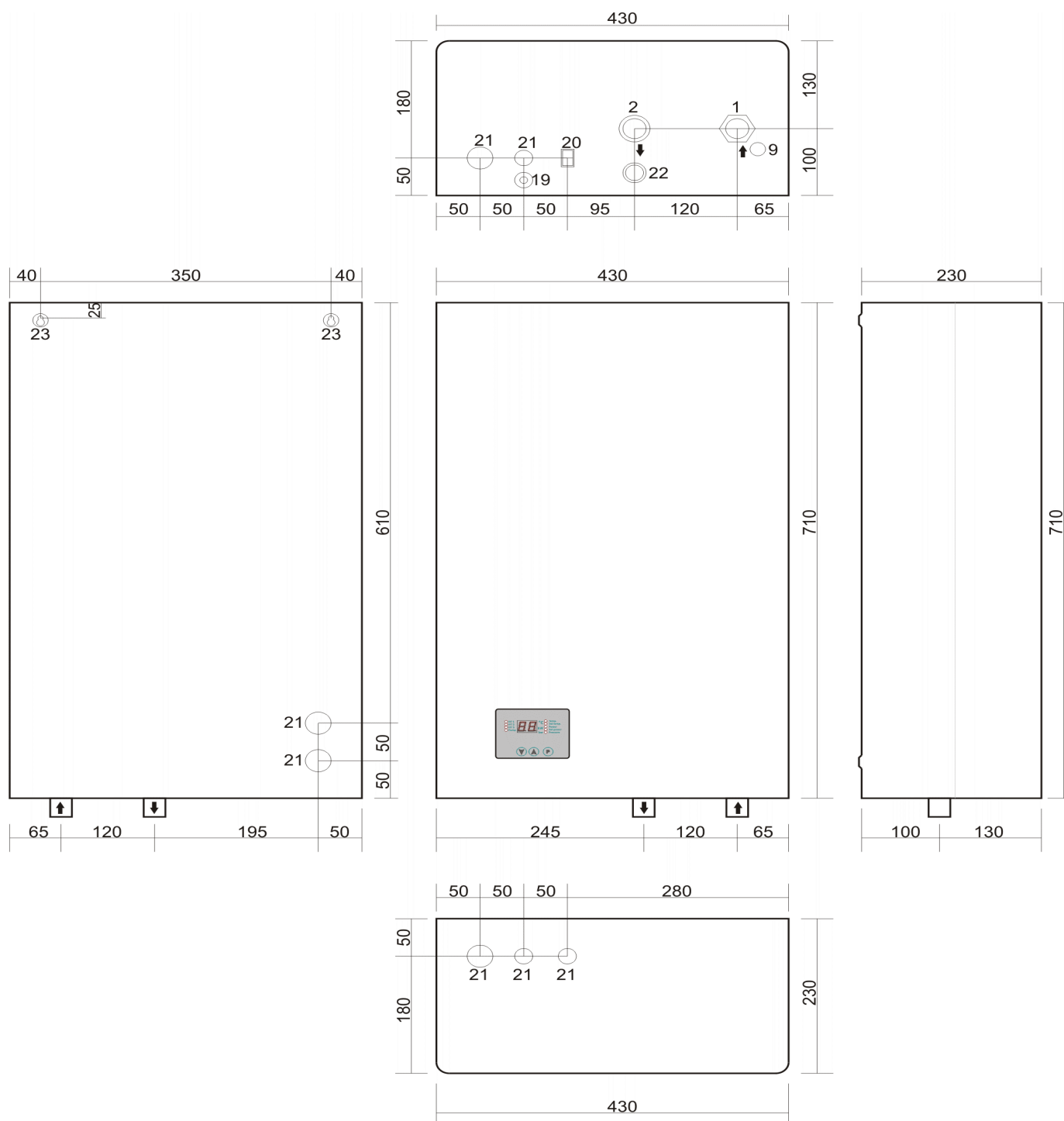

Image 2: Dimensions and connections

2.12.2 Technical data

	Unit	Classic 4,5	Classic 6	Classic 9	Classic 12	Classic 15	Classic 18	Classic 24	Classic 27
Power	kW	4,5	6	9	12	15	18	24	27
Usability level	%	99	99	99	99	99	99	99	99
Number of power grades		3	3	3	3	3	3	3	3
Division of power grades	kW	3×1,5	3×2	3×3	3×4	3×5	3×6	3×8	3×9
Network voltage	V AC	3N ~ 400/230V 50Hz							
Ingress Protection rating		IP40							
Needed fuses for three phase power supply	A	3×16	3×16	3×20	3×25	3×25	3×32	3×40	3×50
Minimum cable cross-section for three phase power supply	mm ²	5×2,5	5×2,5	5×2,5	5×4	5×4	5×4	5×6	5×6
Needed fuses for three phase power supply	A	1×25	1×32	1×50	-	-	-	-	-
Minimum cable cross-section for single phase power supply	mm ²	3×4	3×4	3×6	-	-	-	-	-
Safety valve	bar	3							
Max allowed working pressure	bar	2,6							
Min allowed working pressure	bar	0,4							
Temperature range	°C	10 ÷ 80							
Safety thermostat	°C	95							
Water volume in boiler	ℓ	12,5							
Expansion dish volume	ℓ	8							
Connection of start line		DN20 (3/4")							
Connection of return line		DN20 (3/4")							
Device mass (without water)	kg	23	23	24	24	24	25	25	25
Dimensions	mm	710x430x230 (Height × Width × Depth)							
Microprocessor Un		EK_CPU_LCTR2 / LCI2							

Table 3: Technical data of Device

Important: if connecting to mono phase power please consult technical person about technical issues.

3. Transportation



NOTE: Transport damages

- ▶ Pay attention on instructions for transportation on packaging
- ▶ Use adequate transportation means, i.e. carts for bags with tighten strip. The product should be **in horizontal position** during transportation
- ▶ Avoid shocks or collisions

- Packed boiler put on carts for bags if needed secure it with strip and drive it to its mounting place
- Remove packaging
- Remove packaging materials and dispose it in ecologically acceptable manner

4. Installation of device



CAUTION: Human or material damages occurred because of irregular installation!

- ▶ Never install boiler without expansion dish (AG) and safety valve
- ▶ Boiler must not be installed in protective zone of important area or at the place of bath



NOTE: Material damage due to freezing!

- ▶ Boiler must be installed only in room safe of freezing

4.1 Be careful prior to assembly



NOTE: Material damage occurred due to non-compliance with further instructions!

- ▶ Respect instructions for boiler and all installed components

Prior to installing take care of the following:

- All electrical connectors, protective measures and fuses should be done by professional person respecting all valid norms, regulations and local laws
- Electric connector should be done according to the connecting plans
- After corresponding installation of device execute grounding of the plant
- Before opening device and all works turn off electric supply
- Non-professional and non-authorized attempts to connect device under voltage can produce material damage of device and hazardous electrical shocks

4.2 Distances



DANGER: Fire threat due to burnable materials and liquids!

- ▶ Do not dispose burnable materials and liquids close to the boiler
- ▶ Let know the user the valid regulations for minimum distances from burnable materials (section 2.7)

- Comply with regulations on electric installations and minimum distances in force in subject countries
- Place boiler on the wall in such manner to leave free space as illustrated in the Image 3

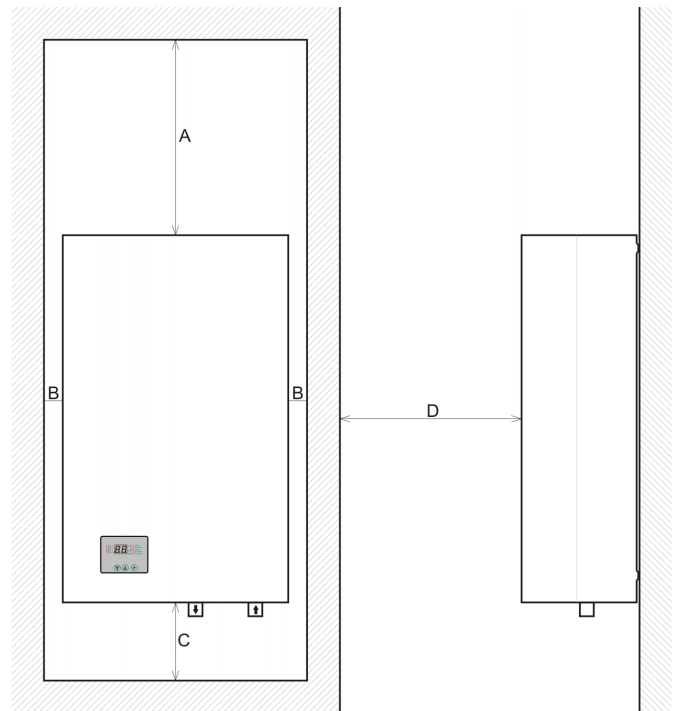

Image 3 : Minimum distance during installation

A = 500mm / B = 50mm / C = 200mm / D = 500mm

4.3 Demounting front boiler casing

Boiler casing can be removed for simple handling and installation (image 4)

- ▶ Unscrew 3 bolts at top lid
- ▶ Unscrew 3 bolts at bottom lid
- ▶ With slow pulling toward you demount front casing of the boiler

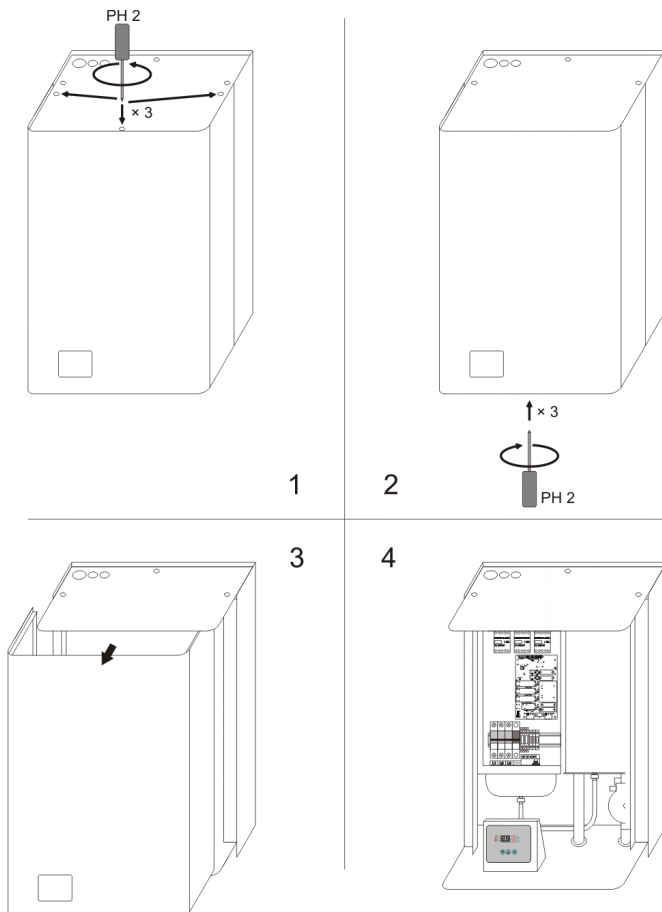

Image 4 : Opening the boiler (Demounting front casing)

4.4 Mounting boiler



NOTE: Material damage occurred by irregular installation on the wall!

- ▶ It is necessary to use proper material for fixing

This chapter describes boiler mounting on the wall

- Draw position of drilling holes for mounting set respecting minimum distances (image 3)
- Drill holes upon dimensions given in (image 2)
- Put into drilled holes plastic dowel enclosed in device packaging (or adequate dowel for unusual kind of wall)
- Then screw bolts into delivered dowels (or other) in such way that are left out from the wall min 5 mm-max 10mm

- Carefully hang device on the wall
- Make sure that boiler is placed vertically
- Fixed boiler on the wall by mounting set and screw

4.5 Hydraulic attachments execution



NOTE: Material damages caused by permeable connections!

- ▶ Attachment duct lines install without connecting on boiler connections

Heating duct lines connect as follows:

- ▶ Connect return line on connection IN. Be sure to install a dirt catcher on the heating return line. **A mechanical failure of the pump that occurs within the warranty period will not be warranted unless a dirt catcher is installed.**
- ▶ Connect start line on connection OUT.

4.6 Systems on which the EI-Cm Classic Plus Boiler can be connected

- All systems for heating the space designed for 80/60 temperature regime (or lower)
- Closed heating systems
- Systems with boiler on solid fuel



WARNING! When connecting boiler to such system it is mandatory to take care that both pumps in the system push water in the same direction to prevent flow crash. Increased hydraulic tensions are possible including

- It can be used as heating device for water in accumulating boilers over exchanger.
- It can also be used in certain technological processes providing that there is no need for water temperature higher than 60°C.

It must not be used for direct heating of domestic hot water.

4.7 Filling the installations and watertight testing



Before system filling the boiler must be connected on electric installations and turned on, over ON/OFF switcher at bottom side of the boiler, to STAND BY regime to follow up with pressure value in installations on display.

Using buttons ▼ and ▲ adjust thermo-regulation to pressure measuring mode (LED diode shines near the mark „bar“).

4.7.1 Filling the boiler with heating water and sealing test

Waterproof should be tested prior to put on the boiler.



DANGER: Injuries and/or material damages can occur with overpressure when testing watertight!

High pressure can damage regulatory and safety devices and reservoir.

- ▶ After filling with water set the boiler on pressure that is equal to the opening pressure of safety valve
- ▶ Comply with maximum pressure of installed components
- ▶ After testing sealing, open again closing valves
- ▶ Make sure that all pressures, regulatory and safety parts work correctly



DANGER: Health threat due to mix of drinking water!

- ▶ It is demanding to respect state norms and regulations on avoiding mix drinking water (with water from heating installations)
- ▶ Comply with EN 1717



NOTE: Installation damage due to bad quality of water! Heating installation can be damaged by corrosion or scale depending on water characteristics.

- ▶ Comply with filling requests for water according to VDI 2035 or project documentation and catalogue

1. **Check the expansion vessel pressure** If the pressure level is below the recommended (1 bar) - inflate the expansion tank. Make sure that the closed boost option (integrated in the boiler) is sufficient to connect to the existing heating system. **If necessary, an additional expansion tank must be installed.**
2. Open faucet for filling and exhausting
3. Fill the boiler slowly; watch pressure on display (image 5)

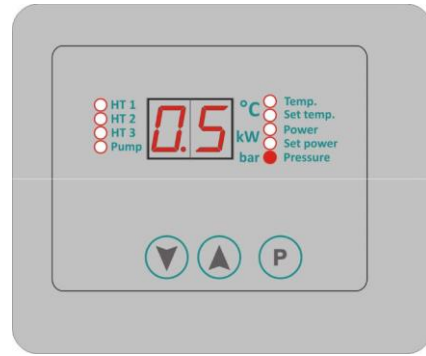

Image 5: Display with marked pressure



NOTE: Material damage due to temperature tension.

- ▶ If you fill the boiler in hot condition, temperature tension can cause cracks due to tensions. Boiler will start to leak
- ▶ Fill the boiler only in cold condition (temperature of empty duct can be max 40°C)
- ▶ Fill the boiler only through quick valve on pipe installation (return line) of the boiler

When working pressure is reached close the faucet.

- Use vent valve to air vent the boiler (image 1, position 10)
- Air-vent the installation through valve on radiator
- When lower working pressure by air vent, water must be re-filled
- Test watertight according to local regulations
- After watertight testing, open all elements that were closed due to filling
- Check if all safety elements work correctly
- When the boiler is tested and no leaking was spotted - adjust correct working pressure
- Remove hose from the filling/exhausting faucet
- Enter working pressure values and water quality into instructions for handling

During the first filling of repeated filling or when change the water

- Comply with requests for filling water

4.7.2 Heating pump air emission and de-blocking

▶ The pump **Wilo-Para MSL/6-43/SC / Mikoterm GPA15-7.5 III Pro Z178** in this device has an automatic air discharger and no action is required for air discharging from the pump. If not fully vented, access manual venting according to the instructions in **Chapter 11.**

When the **WILO MSL 12/5 oem 3P** pump (installed in the Classic boiler) is blocked, proceed as follows:

- ▶ Unscrew the large center screw on the front of the pump.
- ▶ Try to carefully release the shaft with a screwdriver inserted into the hole that covered the central screw.
- ▶ Turn the screwdriver a few turns until the pump rotor starts to rotate slightly.
- ▶ Replace the center screwdriver

4.7.3 Boiler and installation air emission

On the top plate of the boiler there is an air vent. This pot is automatic, so if you follow the rule of slow charging installation and boiler, additional manual venting will not be necessary.

5. Electric connecting



DANGER: Life threat from electric shock!

- ▶ Electric works must be done only by qualified person
- ▶ Turn off voltage supply before opening device and secure it against accidental turn on
- ▶ Comply with assembly regulations



When connecting boiler on electric installation take care on connections scheme and connecting plans. Respect mandatory diameters of cables and fuses power outside the boiler



This device is manufactured for connection to three-phase power supply (3N ~ 400/230V 50Hz)

5.1 Positions of introducer for the introduction of the power cable

This device is equipped with three (3) sets of introducers for power cable

I below set of cable introducers

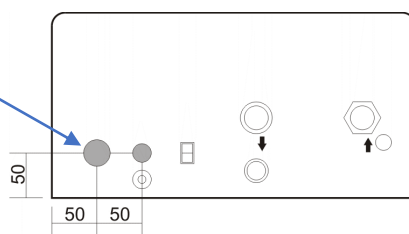

I set introducers (main set) is on lower side (below) of device. They are on lower plate of device in the back left corner (image 6). It is intended for connecting device when power cable comes from the lower side of the boiler.

II rear set of cable introducers

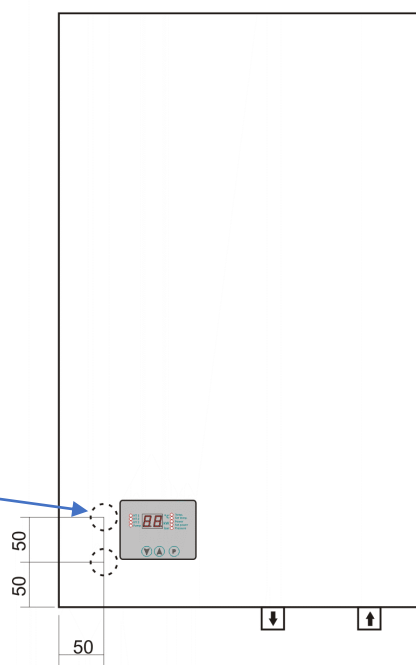

II set introducers is placed on the rear of device and is used when cables on the wall are prepared for the boiler. They provide power cable from the wall to get directly into the boiler. When front lid is removed, it is visible in lower left side two openings of dimensions of 28 mm, placed one above the other. This mode of connecting secures just aesthetic function because cables are not visible (image 6).

III top set of cable introducers

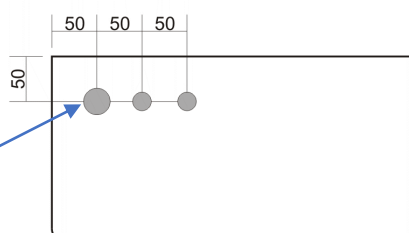

III set introducers are placed on the top of boiler in rear left corner (image 6). They are intended for connecting device when power cable comes from the upper side of device.

Image 6: Illustration of the position of cable introducers on the boiler

5.2 Connecting power (voltage) cable

- Commencing should be performed according to the mounting scheme as given in the image 7
- In the boiler, instead of classical row immobilizer are placed three pole automatic fuses to introduce the power cable. This set of automatic fuses has remote power trigger superstructure, enabling safety set having short-lasting electric power protection and ability to react on overheating (signal from safety thermostat activates power trigger) and simultaneously turn off supply of all three phases into device
- Phase conductors are connected to three-pole fuses (L1, L2, and L3)



WARNING! When connecting phase conductors it is demanding to tight well screws in automatic fuses to achieve better joint between cable and clamp



DANGER! If there is no good joint between cable and clamp, then uncontrolled warning of fuses can occur and its termination at the end

- When introducing a power cable into the boiler, through any selected set of glands, carefully patch the cable to the three-pole automatic fuses to avoid damaging the cable sets inside the device



NOTE! Only qualified person may execute connecting this device

- Neutral (zero) duct line is connected to corresponding row immobilizer (N. Row immobilizer of zero duct line is of blue colour
- Grounding duct line should be connected in the row immobilizer clearly labeled with grounding symbol. Row immobilizer of the duct line for grounding is of green-yellow colour



NOTE: Remote voltage trigger is connected by manufacturer within safety set of this device and **no cable** should be connected with it



NOTE: Room thermostat is connected on additional row immobilizers (5V IN) and it interrupts voltage of 5V DC that comes from boiler table microprocessor

- ▶ It is recommended to use room thermostats with independent power supply like batteries
- ▶ This boiler is not predicted to work without room thermostat or external control unit

- When you are finished connecting the power cord and room thermostat, the fuse set must be lifted together with the remote voltage trigger before the unit is closed (before assembling the front panel) to ensure the power supply to the boiler

5.3 Scheme of power cable connecting

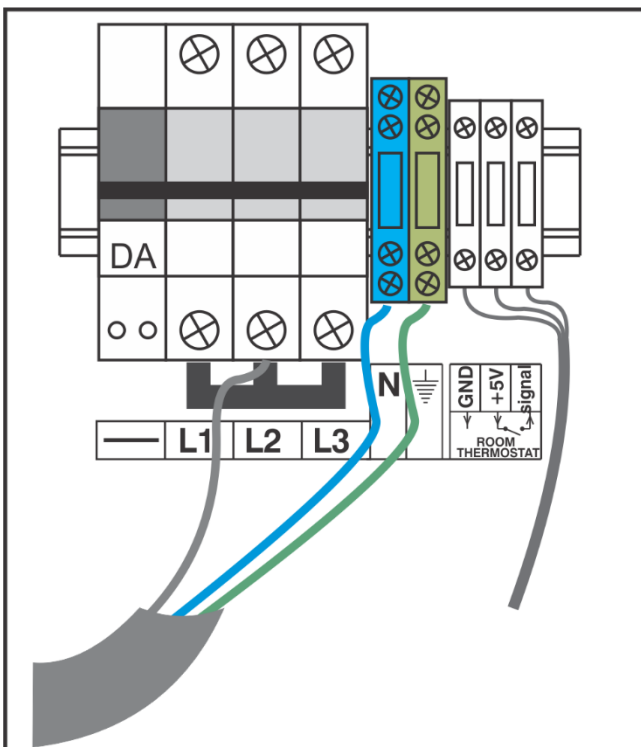

Image 7a: NOARK fuses

Scheme of boiler connecting to mono-phase power supply
– ONLY FOR POWER OF 4,5kW, 6kW AND 9kW

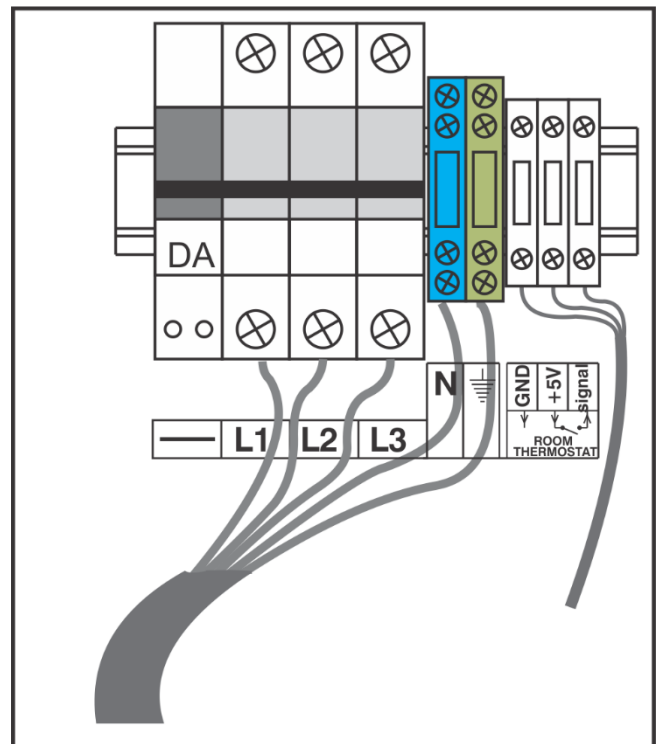

Image 7b: NOARK fuses

Scheme of boiler connecting on three-phase power supply

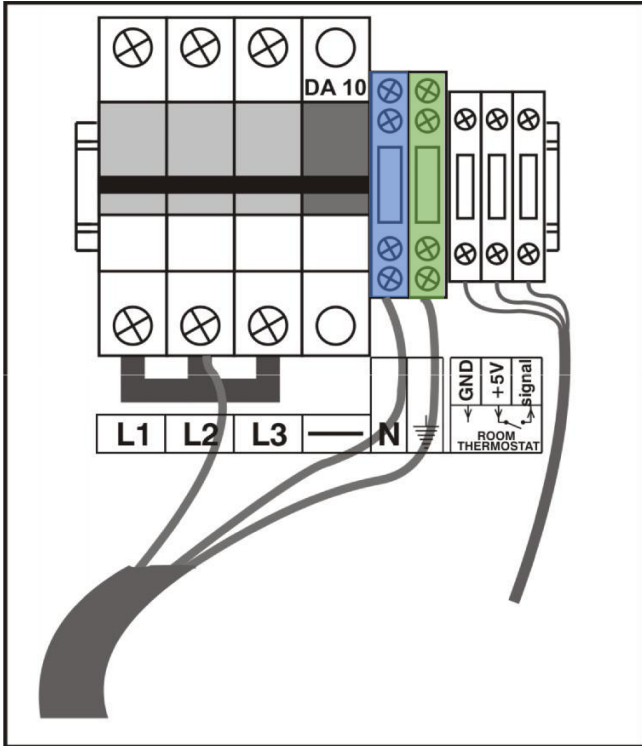

Image 8: ETI fuses
 Scheme of boiler connecting to mono-phase power supply –
ONLY FOR POWER OF 4,5kW, 6kW AND 9kW

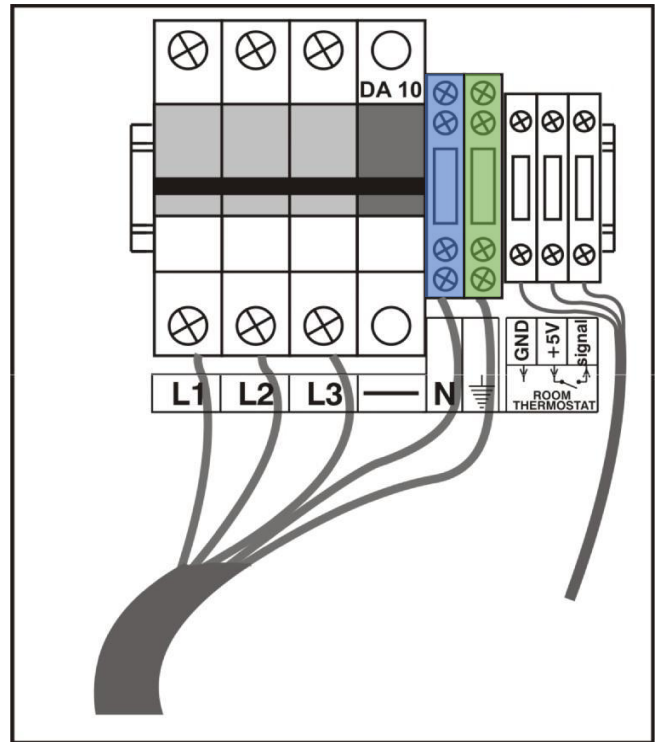

Image 9: ETI fuses
 Scheme of boiler connecting on three-phase power supply

5.4 Connect external control of boiler (room thermostat)

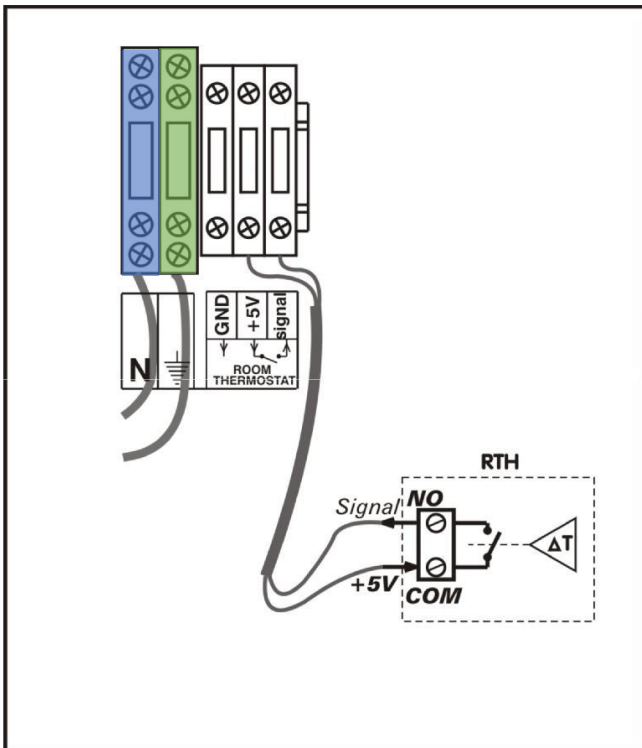

Image 10: Scheme of digital programmed room thermostat connecting with battery supply

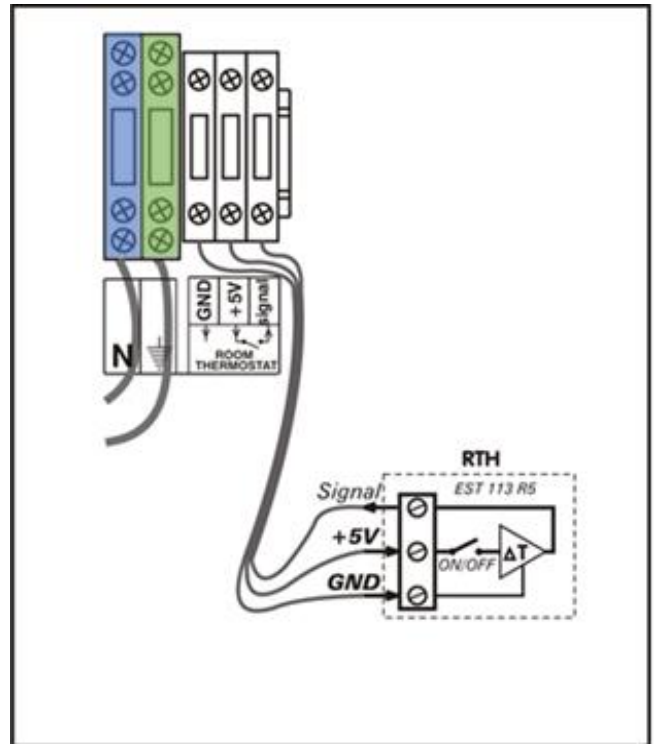

Image 11: Scheme of room thermostat EST 113 R5 connecting

WARNING: Use room thermostat with no-voltage contacts

5.5 Electric schemes of connection



All quoted cross-sections of cables are minimal. Cross-sections that should be placed depend on length of the line and placing mode.

- Cable cross-sections should be dimensioned according to local regulations

Legend	
3P A	Three-pole automatic fuse
DA	Remote power trigger
ST	Safety thermostat (Klixon)
RTH	Room thermostat
RS 1, RS 2, RS 3	Connecting clamps of room thermostat WARNING: voltage 5V DC
P1	Main switcher ON/OFF
CP	Circulation pump
RK1, RK2, RK3	Relay contact (for 9,12,15 and 18kW)
K1, K2, K3	Contact (for 24kW and 27kW)
G1	Heater -3x1500W for boiler of 4,5; 9 kW -3x1667W for boiler of 15 kW -3x2000W for boiler of 6, 12, 18kW -3x2667W for boiler of 24kW -3x3000W for boiler 27kW
G2	Heater -3x1500W for boiler of 9 kW -3x1667W for boiler of 15 kW -3x2000W for boiler of 12, 18kW -3x2667W for boiler of 24kW -3x3000W for boiler of 27kW
G3	Heater -3x1667W for boiler of 15 kW -3x2000W for boiler of 18kW -3x2667W for boiler of 24kW -3x3000W for boiler of 27kW

Legend	
LCTR 2	Microprocessor thermal regulator
OS 1	Electric fuse 230V T500mA
OS 2	Electric fuse 230V T2A
OS 3	Electric fuse 24V T500mA
OS 4	Electric fuse 8V T500mA
KON1	Supply connector (230V AC)
KON2	Circulation pump connection
K 101	Pressure sensor connection
SP	Pressure sensor
K 102	Temperature sensor connection
TS	Temperature sensor
K 105	Interface connection (LCI2)
K 106	Room thermostat connection (RTH)
RE 1	- Heater relay (for boiler of 6kW) - Contact K1 turn on relay (for boiler of all other power)
RE 2	- Heater relay (for boiler of 6 kW) - Contact K2 turn on relay (for boilers of all other power)
RE 3	- Heater relay for boiler of 6kW - Contact K3 turn on relay (for boilers of all other power)

Table 4: Legend of connecting schemes

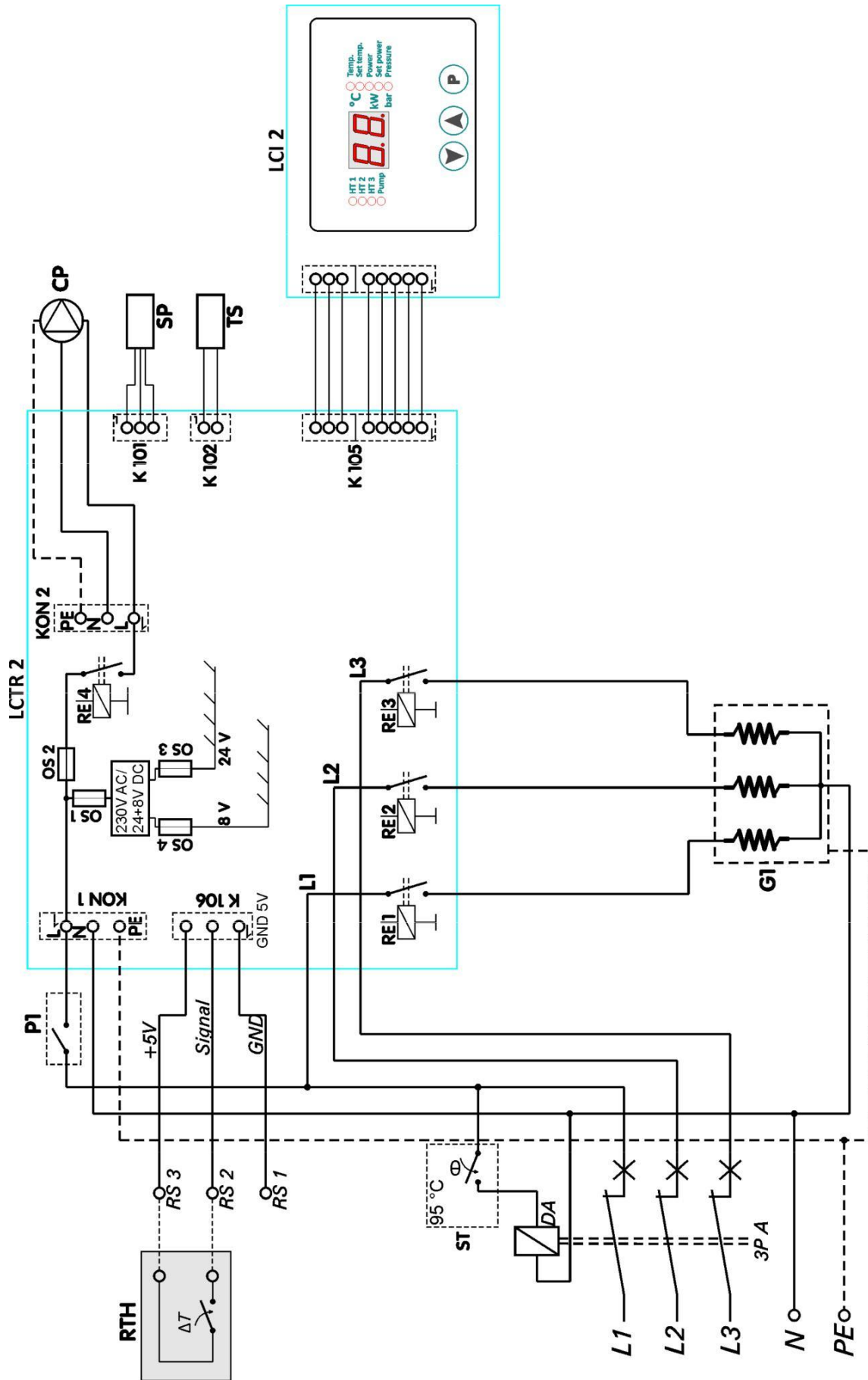

Image 12: Boiler electric scheme EI-Cm Classic with nominal power of 4,5kW and 6kW

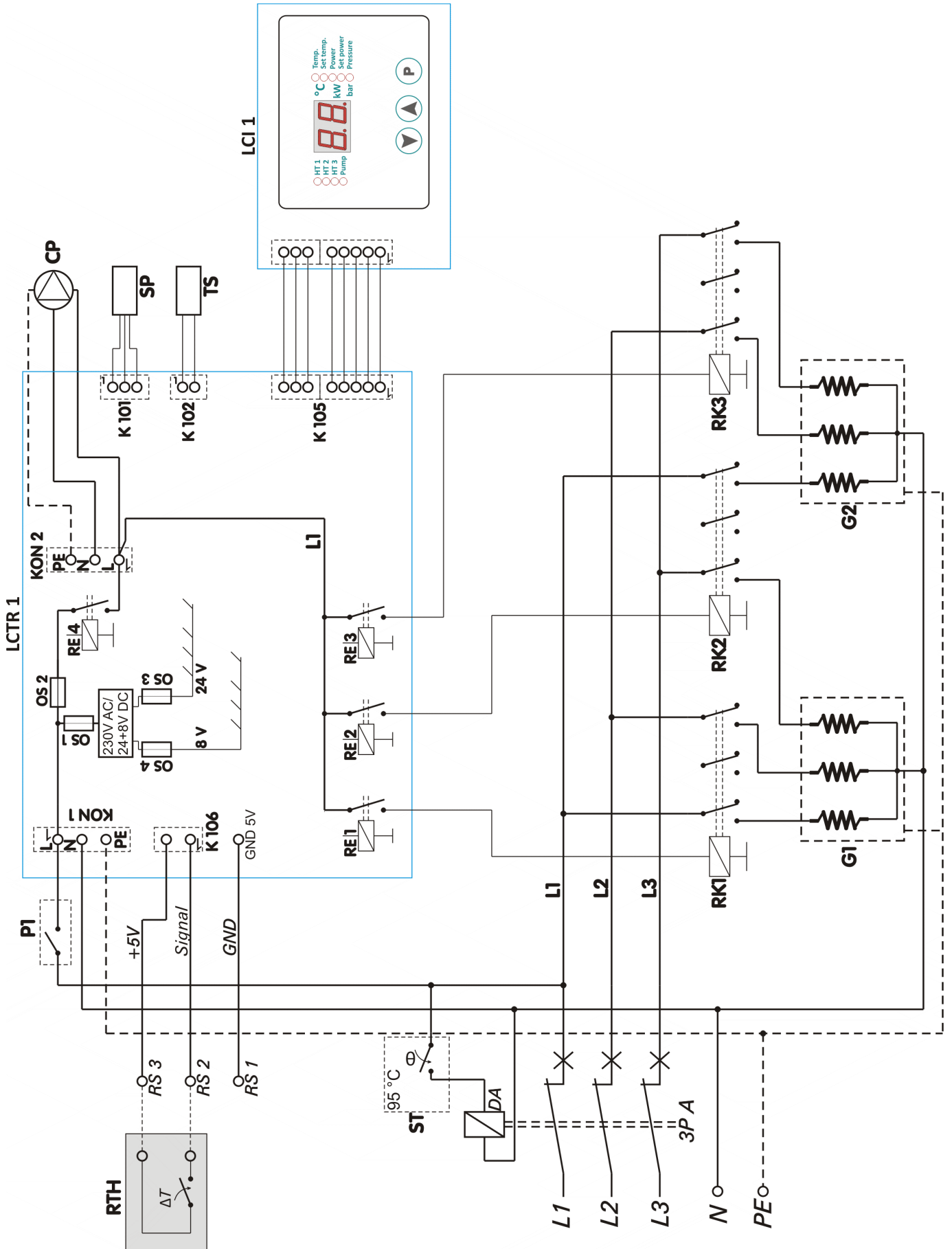

Image 13: Boiler electric scheme **EI-Cm Classic** with nominal power of 9kW and 12kW

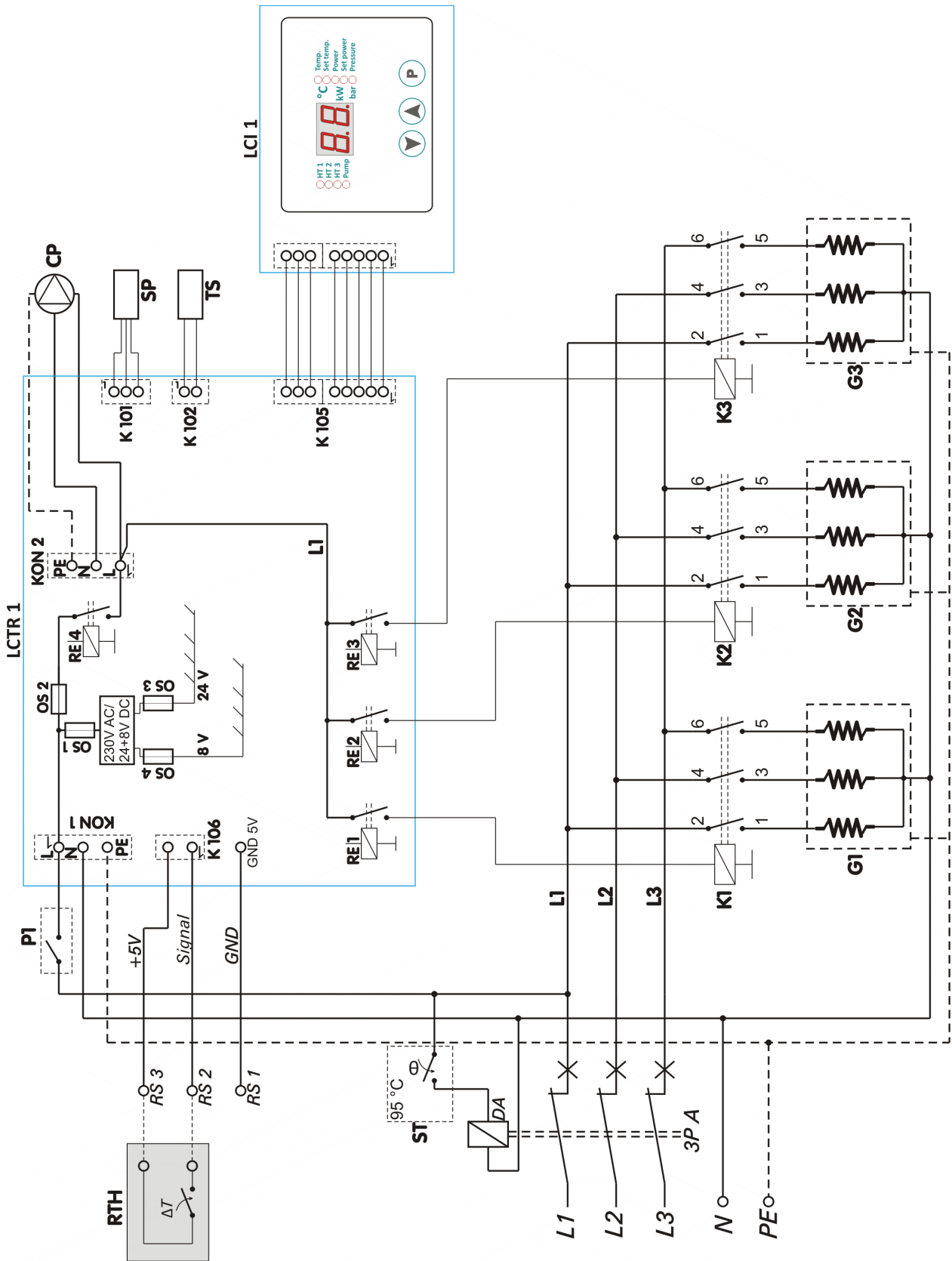



Image 14: Boiler electric scheme EI-Cm Classic with nominal power of 15kW, 18kW, 24kW and 27kW

6. Commissioning

When complete below described works fill in the Commissioning log (chapter 6.3).

6.1 Before commissioning



NOTE: Material damage occurred due to unprofessional operating!
Start-up without sufficient quantity of water destroys device

- ▶ Turn on the boiler and use it only if there is sufficient quantity of water



Boiler must work with minimum pressure of 0.7 bars

Before turn on, test if the following elements and joints are connector correctly and work correctly:

- Watertight of heating installation
- All pipes connected into ducts
- All electric connectors

6.3 Start-up log

6.2 First turn on



NOTE: Material damage due to incorrect handling!

- ▶ Instruct client/user how to handle device

Prior to turn on check if heating installation is filled with water and air-vent

- Turn on main switcher (below device)
- Heating system and device parameters will appear on display
- Device is adjusted by default on min temperature of 10°C and power of 0 kW
- Only the pressure value in installation on display will be the one which you adjusted during filling the installation with water

1.	Boiler type	
2.	Serial number	
3.	Set thermostat regulation	<input type="checkbox"/>
4.	Fill and air-vent heating installation and check sealing of all connectors	<input type="checkbox"/>
5.	Establish working pressure _____ bar Check expansion dish pressure _____ bar	
6.	Test safety devices	<input type="checkbox"/>
7.	Set electric connection according to local regulations	<input type="checkbox"/>
8.	Test function	<input type="checkbox"/>
9.	Users informed, technical documentation submitted	<input type="checkbox"/>
10.	Notes	
11.	Certificate of professional turn on device	Service seal / Signature / Date

Table 5: Start-up log

7. Heating installation handling

7.1 Working Instruction

Safety Instructions

- Only adults familiar with instructions and working mode may operate the boiler
- Make sure there are no children in the boiler area
- Do not dispose or store inflammable materials within safe distance of 400 mm round the boiler
- Inflammable materials must not be placed on the boiler
- User must comply with instructions for operating the boiler
- User may only turn on the boiler (except the first start-up), adjust temperature on the regulating device and turn off the boiler. All other operations must be performed by authorised service
- Authorised person who performed installation is obliged to inform the user about handling and correct and safe work of boiler
- In the event of alert situation, explosion, fire, gas or steam leaking, the boiler must not work
- Be aware of inflammable characteristics of components (**Instructions on installations and maintenance**)

7.2 Overview of the elements to adjust

7.2.1 Device functions

We will give here brief information of the most important characteristics of the boiler **EI-Cm Classic**:

- Electric boiler EI-Cm EI-Cm Classic contains all elements of the boiler sub-station or small boiler room
- This model contains many advanced functions that make easier work with this device and provide longer life and safer handling
- Temperature and hydraulic pressure sensors follow up with changes in heating process sending information to microprocessor which manage the boiler on that base
- Communication between user / installer (servicer) and device is done through user interface where is possible to see important device parameters
- Adjustment is performed through three buttons placed in lower part of control panel

7.2.2 Basic adjustments

The current temperature is continuously displayed on the display, indicating the LED that is lit beside the "Temp" mark. To display other parameters, use the keys ▼ and ▲. In addition to the selected parameter whose value is displayed on the display, the LED indicator lights up.

The "P" key is used to enter the set parameter value (next to the LED). The same key is also used to store the new set parameter value and exit the setting.

The parameters that can be set are:

" Set temp " - set the temperature i

" Set power " - power setting

The temperature can be set in the range of 10 ° C to 80 ° C, in steps of 1 ° C.

The default power can be set in three steps depending on the nominal power of the unit (see table). Turn on / off the heater is carried out periodically with a delay of ~ 3 sec, which avoids the strike on the power grid.

Boiler power	Steps (kW)
4,5 kW	1,5+1,5+1,5
6 kW	2+2+2
9 kW	3+3+3
12 kW	4+4+4
15 kW	5+5+5
18 kW	6+6+6
24 kW	8+8+8
27 kW	9+9+9

Table 6: Power and adjusting steps

- For normal work of this device it is necessary to set working pressure in range between 0.7-2.1 bar (recommendation is 1.0bar) during filling and maintenance
- When working pressure is lower than 0.7 bar LED diode will signal warning (see chapter 7.3.3 pressure warnings), and if working pressure continues to decrease and fall below 0.4 bar the boiler will turn off indicating mistakes on display
- When working pressure is higher than 2.1 bar LED diode will signal warning (see chapter 7.3.3 pressure warnings), and if it increases over 2.6 bar the boiler will turn off



WARNING! If working pressure continues to grow up to 3 bar mechanical safety valve will start to leak heating water out of the boiler.

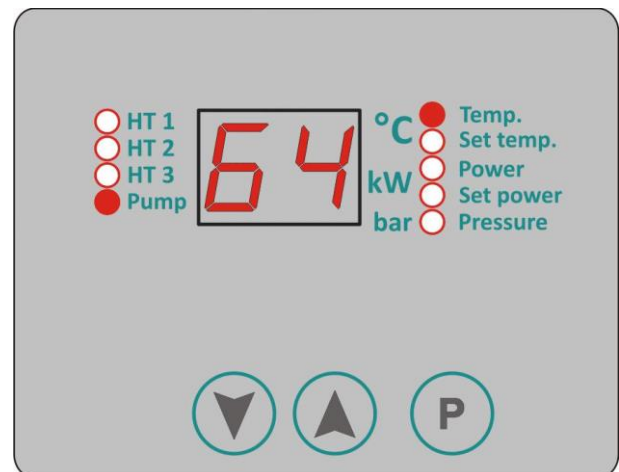

Image 15: Control panel view

- **HT 1:** Indicates work of heater no. 1
- **HT 2:** Indicates work of heater no. 2
- **HT 3:** Indicates work of heater no. 3
- **Pump:** Indicates work of circulating pump
- **Temp:** Present temperature display [°C]
- **Set temp:** Set temperature display [°C]
- **Power:** Present engaged power [kW]
- **Set power:** Set engaged power [kW]
- **Pressure:** Present pressure [bar]
- ▼ Button to reduce parameters value and search down through Menu
- ▲ Button to increase parameters value and search up through Menu
- P: Button to select parameter

7.3 Regulation of heating

- Circulating pump and electrical heaters turn on by command of room thermostat
- When boiler reaches set temperature of water in the system, heaters turn off (with intervals of 3 sec to eliminate shock to electric power net), and pump continues to work until room thermometer turns off. Heaters will again turn on when water temperature fails 2°C below set temperature – if room thermostat requires so. Microprocessor thermo-regulator measures time of work for each heater, changes heaters (if there is inactive heater available) after 30 min of continual work. Such working mode provides equal load of all heaters and relays, and their life-time is significantly longer

i If relay of pump does not turn on for any reason, heaters will not too.

- When room temperature is reached, microprocessor turns off heaters and pump, but after 2 min after heaters turn off – during that time LED diode indicating work of pump will flash meaning that countdown 2 minutes is in progress after which time the pump will turn off

7.3.1 Boiler set temperature adjusting

Using buttons ▼ or ▲ select mod to display set temperature - LED diode starts to flash behind the sign „Set temp“. Press button „P“, LED diode starts to flash next to the sign „Set Temp“ which means it is possible to increase/decrease given temperature of the boiler using button ▼ or ▲ (image 16). Each touch to the button will increase/decrease given temperature of the boiler for 1 °C. Working temperature range is 10 °C ÷ 80 °C.

Confirmation of change must be done by pressing button „P“. If change is not confirmed, 15 sec after pressing any button (except „P“), controller continues to work on old value of set temperature and exits adjusting mode.

When change is confirmed pressing button „P“, display keeps the new value of temperature for 15 sec, and then returns back to basic representation, or the present temperature will appear on display.

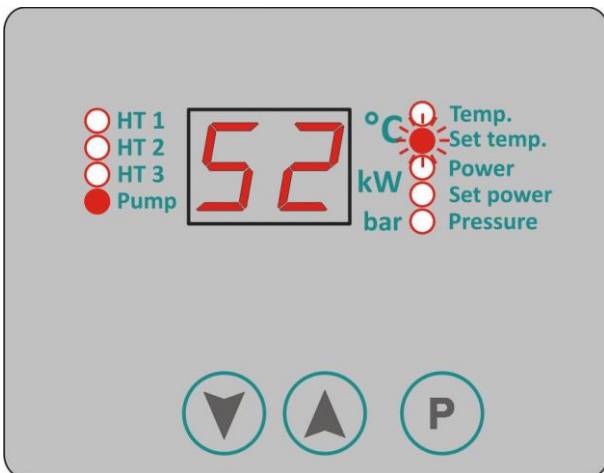

Image 16: Given boiler temperature adjusting

7.3.2 Boiler given power adjusting

Use the ▼ or ▲ buttons to select the mode for setting the default power - the LED next to the "Sets power" indicator lights up. Now press the "P" button - the LED blinks next to "Set Power", which means that it is possible to increase or decrease the default power boiler using the ▼ or ▲ buttons. Each keystroke increases or decreases the default power boiler 1 step power (see Table 6).

In order for the change to be accepted it must be confirmed by pressing the "P" key. If the change is not confirmed, within 15 sec. by pressing any key (except for "P"), the control resumes operation according to the old default power value and exits from the setting mode.

When the default power change is confirmed by pressing the "P" key, the display will display a new setpoint of 15 sec and then return to the basic display, the display will show the current temperature.

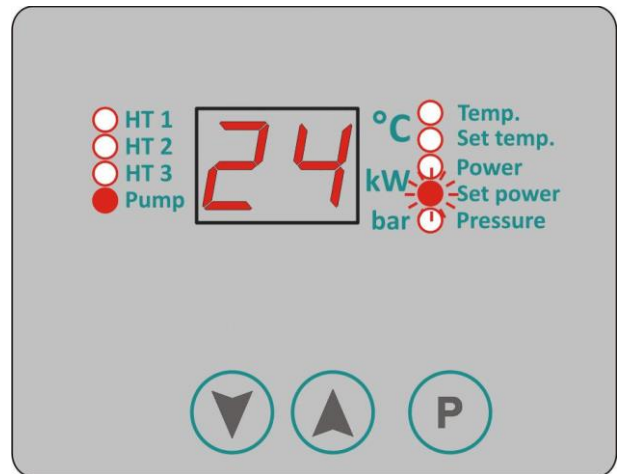

Image 17: Given boiler power adjustment

7.3.3 Warnings about pressure

If the pressure in the system decreases to $P \leq 0.6$ bar, the boiler works normally, but diode indicating pressure measurements starts to flash slowly (image 18). It is necessary to re-fill installations up to $P \leq 0.7$ bar in order to a stop automatic flashing.

If pressure increases up to $P \leq 2.2$ bar, boiler work normally but pressure measurements indicator starts to flash slowly (image 18). It is necessary to reduce the pressure to $P \leq 2.1$ bar in order to stop automatic flashing

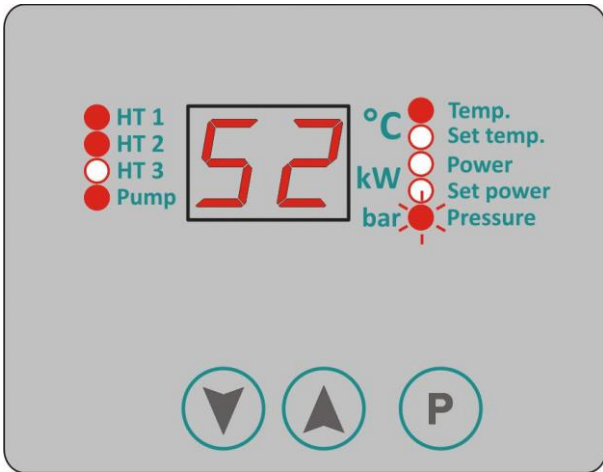

Image 18: Warning- pressure close to disabled value

Pressure measurements are done by digital sensor integrated in circular pump. If the sensor is stopped or in circuit break, then all heaters and pump will turn off (delayed for 2 min), and pressure measurements indicator starts to flash quickly. Display still has present temperature of the boiler (image 19). When select pressure using button ▼ or ▲, instead its value the display will show the code for mistake: **EP** - Error Pressure (image 20).

In this case it is necessary to put off power supply and call authorised service to establish and remove the cause of the problem.

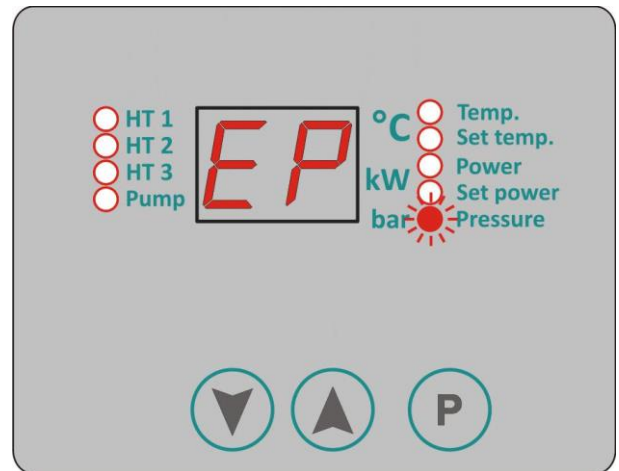

Image 20: Circuit break or pressure sensor break

If the pressure in system decreases on $P \leq 0.3$ bar, the boiler turns off all heaters and pump (delayed for 2 min), and pressure measuring indicator starts to flash quickly (image 19). It is necessary to re-fill installation up to $P \leq 0.7$ bar in order to stop automatic flashing indicating this mistake and to continue normal work of the boiler.

If the pressure in system increases on $P \leq 2.6$ bar, the boiler turns off all heaters and pump (delayed for 2 min), and pressure measuring indicator starts to flash quickly. Display still shows present temperature of the boiler (image 19). It is necessary to reduce pressure to $P \leq 2.1$ bar in order to stop automatic flashing indicating warning and to continue normal work of the boiler according to the set values of parameters.

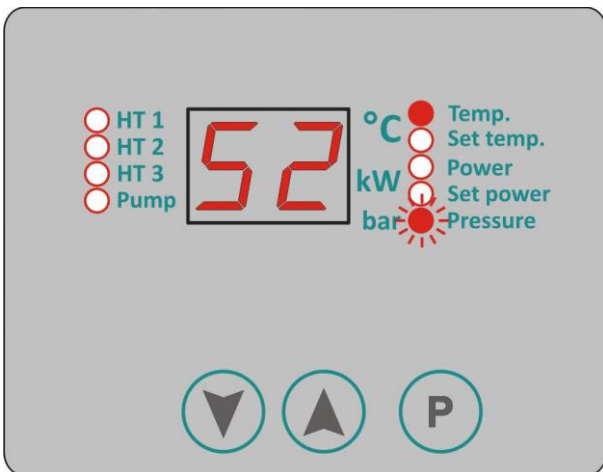

Image 19: Mistake – Exceeding enabled pressure value

7.3.4 Low temperature warning

If temperature of the system decreases to $T \leq 4^\circ\text{C}$, the boiler continues to work normally, but measuring temperature indicator starts to flash **slowly** (image 21). It is necessary to increase temperature to $T \leq 5^\circ\text{C}$ in order to stop automatic flashing of warning indicator.

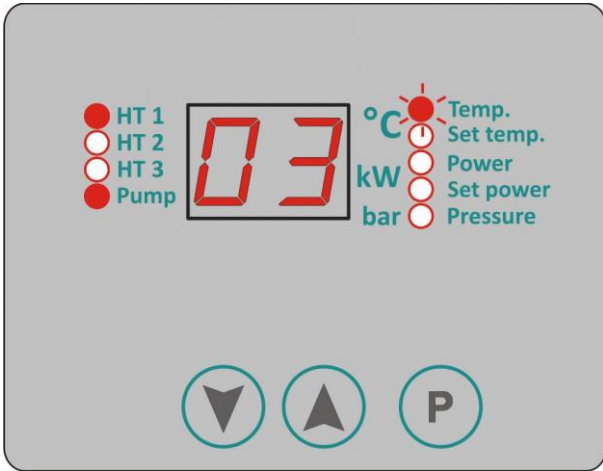

Image 21: Warning- Temperature near restricted low temperature

Present temperature displayed on the screen is possible for values $T \leq -9^\circ\text{C}$. Temperature below -9°C is not possible to be displayed on the screen so the code **EL** will appear on display meaning the temperature is below -9°C , or temperature sensor is in circuit break (image 23).

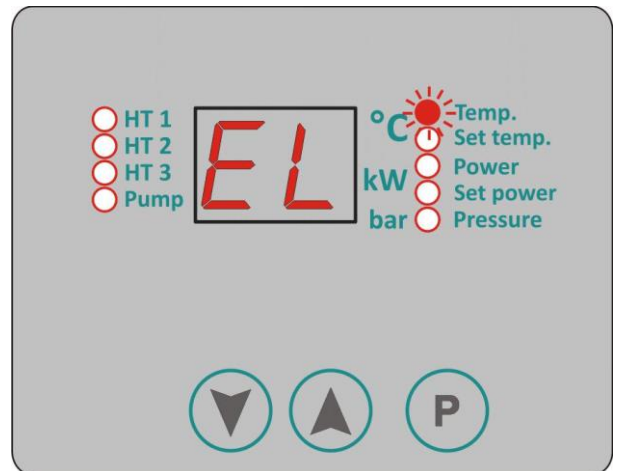

Image 23: Temperature below -9°C or sensor circuit break

If temperature of the system decreases to $T \leq 2^\circ\text{C}$, all heaters and pump will turn off (delays for 2 min), and temperature measuring indicator will flash **quickly** (image 22). With this temperature value there is danger of freezing and boiler damage, so the work of this device will be blocked. To continue with boiler work it is necessary to increase temperature up to $T \leq 5^\circ\text{C}$.

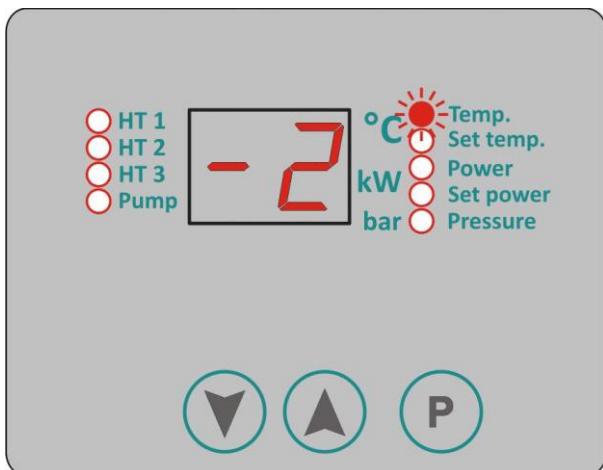

Image 22: Blocked work of the boiler due to danger of freezing

WARNING: Material damage due to freezing

WARNING! If heating system is out of function the freezing can occur

- ▶ It is mandatory to secure the system
- ▶ Empty the entire installation

7.3.5 Warning with high temperature

If temperature of the system increases to $T \geq 85^\circ\text{C}$, the pump works continually (due to taking heating energy through pipe routing network), but measuring temperature indicator starts to flash **slowly** (image 24). It is necessary to decrease temperature to $T \leq 84^\circ\text{C}$ in order to stop automatic flashing of warning indicator and continue with normal work of boiler.

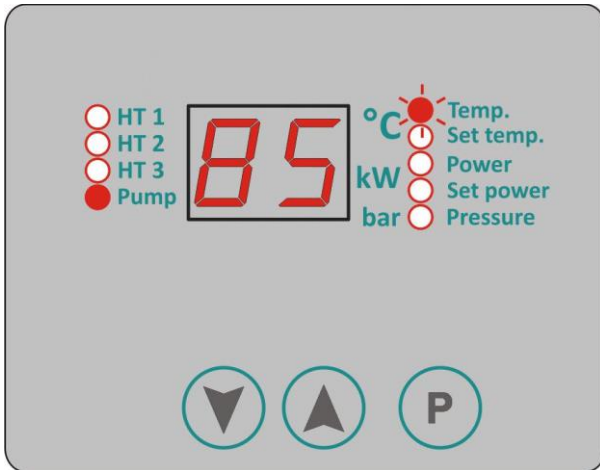

Image 24: Warning – Temperature close to restricted high temperature value

If temperature of the system increases to $T \geq 89^\circ\text{C}$, the pump works continually (due to taking heating energy through pipe routing network), but measuring temperature indicator starts to flash **quickly** (image 25). It is necessary to decrease temperature to $T \leq 88^\circ\text{C}$ in order to stop automatic flashing of this mistake warning indicator.

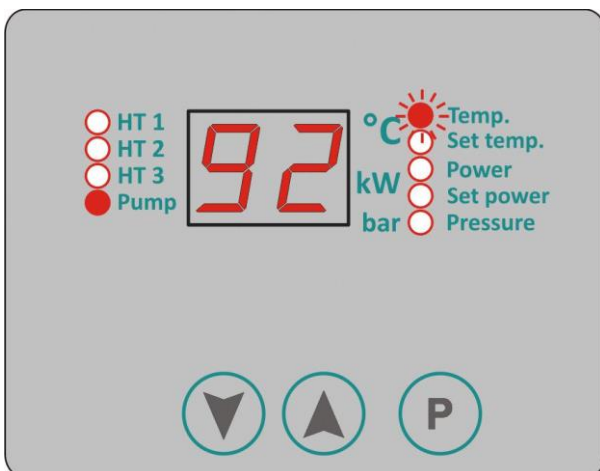

Image 25: Blocked work of the heaters due to danger of thermic overload, pump work continually

If temperature increases to $T \geq 100^\circ\text{C}$, display of its value is not possible to see on the screen so in this will appear code **EH** meaning that temperature is $T \geq 100^\circ\text{C}$ (image 26). Measuring temperature indicator will continue to flash **quickly**.

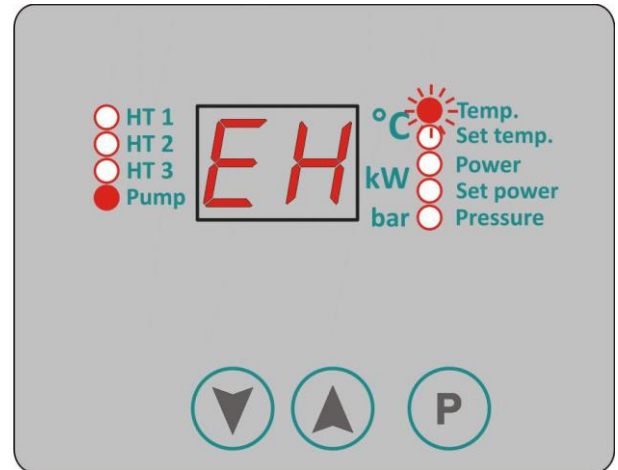

Image 26: Temperature above 99°C



WARNING: Material damage due to overheating

In this case it is necessary to turn off this device out of electric power supply and call authorised service to establish and remove the cause of problem.

If temperature sensor brake occurs, the code **ES** will appear on the screen meaning that temperature sensor is in break (image 27). Temperature measuring indicator will continue to flash **quickly**.

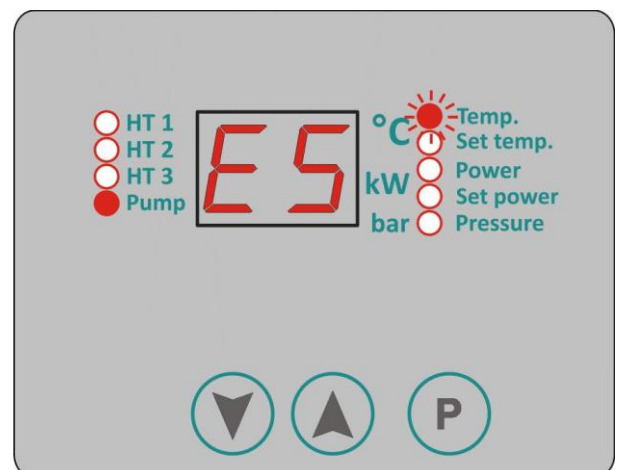

Image 27: Temperature sensor in discontinuity

In this case it is necessary to turn off this device out of electric power supply and call authorised service to establish and remove the cause of problem.

7.3.6 Signal and code of warning and mistakes

- ☀ **Pressure** - slow flashing - **Warning:** Pressure near lower limit ($0,4\text{bar} \leq P \leq 0,6\text{bar}$) or upper limit ($2,2\text{bar} \leq P \leq 2,6\text{bar}$) of allowed pressure
Measure: Bring the system to the necessary pressure value
- ☀ **Pressure** - quick flashing - **Mistake:** Exceeding lower limit ($0,3\text{bar} \leq P$) or upper limit ($P \geq 2,6\text{bar}$) of allowed pressure
Measure: Bring the system to the necessary pressure value

Graphic display of the area of blockade of the boiler work conditioned by the pressure (1.pressure increases→ / 2.pressure decreases←)

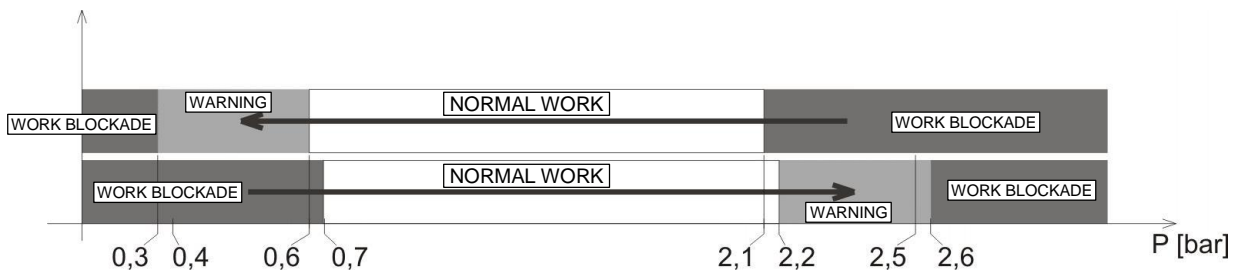

- ☀ **Temp.** - slow flashing - **Warning:** lower limit exceeding ($T \leq 4 \text{ }^\circ\text{C}$) or upper limit ($T \geq 85 \text{ }^\circ\text{C}$) of temperature of the heating system
Measure: Check if valves are open, the functionality of circulation pump and relay/contactactor
- ☀ **Temp.** - quick flashing - **Mistake:** lower limit exceeding ($T \leq 2 \text{ }^\circ\text{C}$) or upper limit ($T \geq 89 \text{ }^\circ\text{C}$) of temperature of the heating system
Measure: Turn off electric power supply for the boiler. Call service

Graphic display of the area of blockade of the boiler work conditioned by temperature (1.temp. increases→ / 2.temp. decreases←)

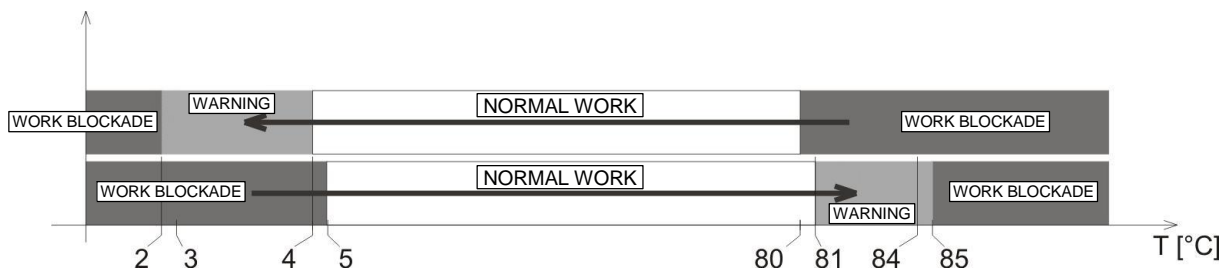

Mistake signals on display

- EP - Mistake:** Pressure sensor in break or circuit break – all turned off
Measure: Turn off power supply. Call service.
- EL - Mistake:** Very low boiler temperature or temperature sensor circuit break – all turned off
Measure: Turn off power supply. Call service.
- EH - Mistake:** Very high temperature ($T \geq 100 \text{ }^\circ\text{C}$) not able to display – all turned off
Measure: Turn off power supply. Call service.
- ES - Mistake:** Boiler temperature sensor breaker – all turned of
Measure: Turn off power supply. Call service.

7.3.7 Room temperature regulator

This device is not produced for work without room temperature regulator. It must be installed in reference room.

Managing temperature of all rooms is done by this remote control. Radiators in reference room should not be equipped by thermo-static valves or these must always be open. All radiators in other rooms must be equipped by thermostat valves. Connecting room-regulator is described in chapter 5.4. When mounting room-regulator in reference room you must comply with manufacturer instructions.

7.3.8 Heating discontinuity

With short-time discontinuity of heating working regime the boiler temperature must be decreased using thermo-regulator of the boiler. To prevent heating installations freezing temperature of the boiler must not be set below 5°C. With longer discontinuity of heating working regime of the boiler must be cut off the power (chapter 7.4).

7.4 Boiler out of power

If heating installation is not in drive, it could freeze with low temperatures.

- Protect heating installations against freezing
 - If there is danger of freezing and boiler is not in drive, discharge entire installation
 - Main power breaker on lower plate put in position „0“ (put off)
-

8. Cleaning and maintenance



DANGER! Life threat of electric power shock!

- ▶ Electric power work must be done only by qualified person
- ▶ Before opening device: turn heating installation off electric power supply using safety switcher and disconnect it from power supply net through corresponding fuse
- ▶ Secure heating installation against accidental turn on
- ▶ Comply with instructions for installation



WARNING: Material damage due to unprofessional maintenance!

Insufficient or unprofessional maintenance of boiler can lead to damage or destruction and to loss of Warranty rights

- ▶ Secure regular, entire and professional maintenance of heating installation
- ▶ Electric parts and work units protect against water and humidity



Use only spare parts delivered by the manufacturer or those approved by manufacturer. There will be no responsibility for damage occurred due to spare parts not delivered by the manufacturer



Control examination log is provided on chapter 8.4

- Perform works in accordance with log on control and maintenance
- All deficiencies remove immediately

8.1 Boiler cleaning

Clean this device externally with wet cloth

8.2 Check working pressure; re-fill water and air-vent installation



DANGER: Health threat due to mix of drinking water!

- ▶ It is demanding to respect state regulations to avoid mix of drinking water (with water from heating installations)
- ▶ Comply with EN 1717



Establish a working pressure of at least 1 bar, depending on the height of the highest point of the installation. If, due to the height of the installation, the operating pressure is greater than 1 bar (eg 1.5 bar) before the system is filled with water, it is necessary to lift the air intake in the expansion vessel to the same value - 1.5 bar

The volume of newly filled water is reduced in the first days after charging due to heating. This creates airbags that create interference in the heating system.

Testing working pressure

- Working pressure of new heating installation should control on daily basis at the beginning of its work. If needed, re-fill water and air vent the system
- Later check working pressure once per month. If needed, re-fill water and air vent the system
- Check working pressure. If it decreases below 1 bar re-fill water
- Re-fill the water
- Air vent the heating installation
- Check working pressure again

8.3 Re-fill the water and air-vent the installation



WARNING: Material damage due to heat tension. Filling heating installations in warm condition can produce cracks due to tension

- ▶ Fill heating installation only in cold condition (temperature of starting duct lines of max 40 °C)



WARNING: Material damage due to frequent re-filling!

Due to frequent water re-filling installations can be damaged by corrosion and carbonate layers depending on water characteristics

- ▶ Test sealing and watertight of heating installations and expansion dish on functionality

- Connect hose on water faucet
- Fill the hose with water and connect to connector for filling/drainage
- Tighten the hose and open the water faucet for filling/drainage
- Slowly fill the heating installation while following up with pressure (manometer)
- During filling procedure air vents the system
- When reach working pressure close the drainage faucet
- When reach working pressure close the drainage faucet
- Remove the hose from filling/drainage faucet

8.4 Inspection and maintenance log



At least once a year perform maintenance or when a check shows the status of installations that require maintenance

The commissioning, inspection and maintenance record serves as an attachment for copying

- Executed works should be authorised by signature and date

Inspection and maintenance works when needed		Date:	Date:	Date:
		_____	_____	_____
1.	Check condition of installations	<input type="checkbox"/>	<input type="checkbox"/>	<input type="checkbox"/>
2.	Visual and functional control	<input type="checkbox"/>	<input type="checkbox"/>	<input type="checkbox"/>
Making working pressure				
3.	• Check pre-pressure of expansion dish	<input type="checkbox"/>	<input type="checkbox"/>	<input type="checkbox"/>
	• Working pressure set on ...	_____ bar	_____ bar	_____ bar
	• Heating installation air vent	<input type="checkbox"/>	<input type="checkbox"/>	<input type="checkbox"/>
	• Check safety heating valve	<input type="checkbox"/>	<input type="checkbox"/>	<input type="checkbox"/>
4.	Clean water filter	<input type="checkbox"/>	<input type="checkbox"/>	<input type="checkbox"/>
5.	Check if there is any damage on electric duct lines	<input type="checkbox"/>	<input type="checkbox"/>	<input type="checkbox"/>
6.	Check if electric control connections and used elements are fitted; tighten it if needed	<input type="checkbox"/>	<input type="checkbox"/>	<input type="checkbox"/>
7.	Check thermo-regulator on boiler	<input type="checkbox"/>	<input type="checkbox"/>	<input type="checkbox"/>
8.	Check function of safety parts	<input type="checkbox"/>	<input type="checkbox"/>	<input type="checkbox"/>
9.	Check remote control function	<input type="checkbox"/>	<input type="checkbox"/>	<input type="checkbox"/>
10.	Check insulation of the rod heater	<input type="checkbox"/>	<input type="checkbox"/>	<input type="checkbox"/>
11.	Check function of grounding device	<input type="checkbox"/>	<input type="checkbox"/>	<input type="checkbox"/>
12.	Check insulation of electric switchboard	<input type="checkbox"/>	<input type="checkbox"/>	<input type="checkbox"/>
13.	Check heating pump function	<input type="checkbox"/>	<input type="checkbox"/>	<input type="checkbox"/>
14.	Make final control of inspection works and document results of measuring and inspecting	<input type="checkbox"/>	<input type="checkbox"/>	<input type="checkbox"/>
		Seal/Signature	Seal/Signature	Seal/Signature
15.	Certification of professionally conducted inspection			

Table 7: Inspection and maintenance log

9. Environment protection /Waste disposal

One of the basic concepts of business is environment protection. Quality of products, thriftiness and environment protection are equally valuable goals for us.

It is critical to strictly comply with law and regulations on environment protection. In order to protect environment and respecting economy concepts we use only the best technique and materials.

Packaging

Regarding packaging, we respect system of recycling which is specific in certain states and which secure optimal recycling. All materials applied for packaging do not harm environment and It is possible to recycle it.

Old devices

Old devices contain valuable materials that can recycle. Structures are easily demountable and plastic materials are labeled. In such manner structures can be sorted and deliver for recycling.

10. Troubles and troubleshooting



Troubleshooting on regulations and hydraulics must be done by an authorised firm



For repairs use only original spare parts

TROUBLE	DESCRIPTION	CAUSE	MEASURE
Boiler does not react after turn on of main switcher	Display does not react, other components do not work	<ul style="list-style-type: none"> Boiler is out of power supply Fuses on bottom plate are off Vanishing of managing phase Damage of main fuse ON/ OFF 	<ul style="list-style-type: none"> Provide power supply Turn on fuses Check if fuses have three phases on output Change damaged part
Boiler does not heat or insufficiently heat/heating pump works	All on display are within recommended values but boiler does not make hot water	<ul style="list-style-type: none"> Lack of 1 or 2 phases Small power of boiler Some relay damaged Some heater damaged 	<ul style="list-style-type: none"> Check all three phases Check set power of boiler Change damaged part Change damaged part
Boiler heats but it is very noisy	Higher level of noise during work	<ul style="list-style-type: none"> Air in the system Small water flow Possible carbonate layer on heater 	<ul style="list-style-type: none"> Check if the system is air vented and vent it Check valves below boiler and open it Clean filter below boiler Take out heaters and clean it (this is not included in claims during warranty period)
Boiler turns on quickly	Reaches temperature too quickly and turns on	<ul style="list-style-type: none"> Valves below the boiler off Pump fuse stop to work Pump jammed Pump inaccurate 	<ul style="list-style-type: none"> Open valves Change inaccurate part Start pump rotor Change inaccurate part
Great oscillations of working pressure	Too fast and too big changes of working pressure	<ul style="list-style-type: none"> One valve off Expansion dish pressure inadequate Inaccurate dish 	<ul style="list-style-type: none"> Open the valve Check pressure in expansion dish and if needed set dish pressure adequately Change inaccurate part

Table 8: Troubles and troubleshooting

11. Instruction for projecting

11.1 Pump Wilo-Para MSL/6-43/SC



- 1. Composite OEM pump housing
- 2. Pump inlet MS ¼ "SN
- 3. Pump output terminal composite ¼ " SN
- 4. Automatic air vent
- 5. Safety valve 3bar
- 6. Pressure sensor
- 7. Pump head with electronics
- 8. Pump Mode Selector Button (settings)
- 9. Drain faucet

Wilo Para MSL / 6-43 / SC is a circulating pump for heating systems, heating systems for family houses and other similar systems. The most important characteristics of this pump are:

- Maximum flow rate: 2.1 m³ / h
- Maximum water column height: 6.8 m
- Maximum media temperature (at ambient temperature 58 °C): 100 °C
- Maximum glycol concentration in the system: 50%
- Minimum and maximum rotor speed: 2430 ~ 4300 rpm
- Minimum and maximum pump power: 3 W ~ 43W
- Minimum and maximum pump current (230V AC): 0.04 4 0.44A
- Energy Efficiency Index (EEI): ≤ 0.2
(This energy efficiency index in practice means that the Wilo-Para pump consumes up to 80% less electricity compared to earlier versions of the same class pumps that did not have electronic power regulation).

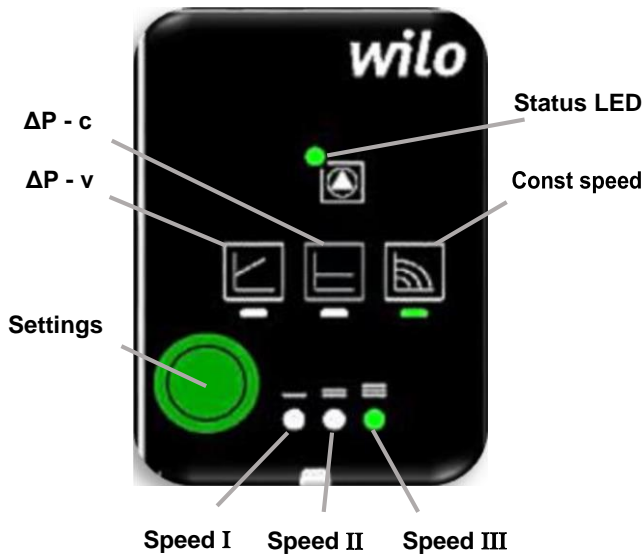

	LED display	Control mode	Pump curve
1.		Constant speed	II
2.		Constant speed	I
3.		Variable differential pressure Δp-v	III
4.		Variable differential pressure Δp-v	II
5.		Variable differential pressure Δp-v	I
6.		Constant differential pressure Δp-c	III
7.		Constant differential pressure Δp-c	II
8.		Constant differential pressure Δp-c	I
9.		Constant speed	III

Faults, causes and remedies

The troubleshooting must only be carried out by a qualified specialist, and work on the electrical connection must only be carried out by a qualified electrician.

Faults	Causes	Remedy
Pump is not running although the power supply is switched on	Electrical fuse defective	Check fuses
	No voltage supply at pump	Rectify the power interruption
Noisy pump	Cavitation due to insufficient suction pressure	Increase the system pressure within the permissible range
		Check the delivery head and set it to a lower head if necessary
Building does not warm up	Thermal output of the heating surfaces is too low	Increase setpoint
		Change the control mode from Δp -c to Δp -v

Fault signals

- The fault signal LED indicates a fault.
- The pump switches off (depending on the fault) and attempts a cyclical restart.

LED	Faults	Causes	Remedy
Lights up red	Blocking	Rotor blocked	Activate manual restart or contact customer service
	Contacting/winding	Winding defective	
Flashes red	Under/overvoltage	Power supply too low/high on mains side	Check mains voltage and operating conditions, and request customer service
	Excessive module temperature	Module interior too warm	
	Short-circuit	Motor current too high	
Flashes red/green	Generator operation	Water is flowing through the pump hydraulics, but there is no mains voltage at the pump	Check the mains voltage, water quantity/pressure and the ambient conditions
	Dry run	Air in the pump	
	Overload	Sluggish motor, pump is operated outside of its specifications (e.g. high module temperature). The speed is lower than during normal operation.	

Activating factory setting

The factory setting is activated by pressing and holding the operating button whilst switching off the pump.

- Press and hold the operating button for at least 4 seconds.
- All LEDs flash for 1 second.
- The LEDs for the last setting flash for 1 second.

Decommissioning

Shutting down the pump

Shut down the pump immediately if the connecting cable or other electrical components are damaged.

- Disconnect the pump from the power supply.
- Contact a service technician

Maintenance

Cleaning

- Carefully remove dirt from the pump on a regular basis using a dry duster.
- Never use liquids or aggressive cleaning agents.



Manual restart

- The pump attempts an automatic restart upon detecting a blockage. If the pump does not restart automatically:
 - Activate manual restart via the operating button: press and hold for 5 seconds, then release.
 - The restart function is initiated, and lasts max. 10 minutes.
 - The LEDs flash in succession clockwise.
 - To cancel, press and hold the operating button for 5 seconds.
- If the fault cannot be remedied, contact an authorized service center.**



NOTICE

After the restart, the LED display shows the previously set values of the pump.



Venting

- Fill and vent the system correctly. If the pump does not vent automatically:
- Activate the pump venting function via the operating button: Press and hold for 3 seconds, then release. The pump venting function is initiated and lasts 10 minutes. The top and bottom LED rows flash in turn at 1 second intervals.
- To cancel, press and hold the operating button for 3 seconds.



NOTICE

After venting, the LED display shows the previously set values of the pump.



Lock/unlock the button

- To activate the key lock, press and hold the operating button for 8 seconds until the LEDs for the selected setting briefly flash, then release.
 - LEDs flash constantly at 1-second intervals.
 - The key lock is activated: pump settings can no longer be changed.
- The key lock is deactivated in the same manner as it is activated.



NOTICE

All settings/displays are retained if the power supply is interrupted.

11.2 Pump WILO MSL 12/5 oem 3P

Total height of the water column of the heating pump

The total height of the water column of the heating pump is shown in the following diagram with the corresponding upper and lower limit values.

Heating pump characteristic

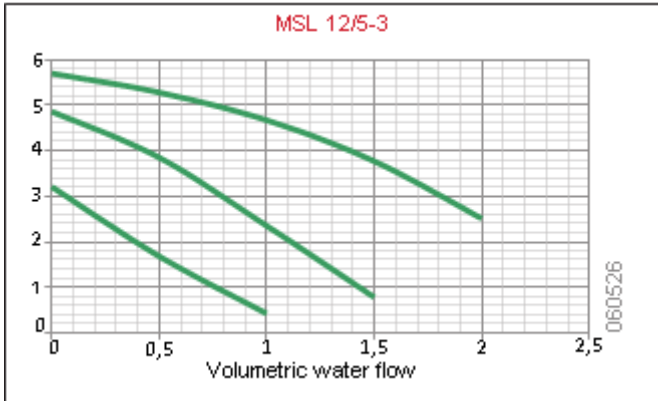

Basic characteristics of the WILO MSL 12/5 oem 3P pump

	n l / m	P1 W	I A	Capacitor µf / VDB
MSL12/5	max 2310	84	0,37	2 /400
	2040	59	0,28	
	min 1560	40	0,18	

Table: WILO data, Germany

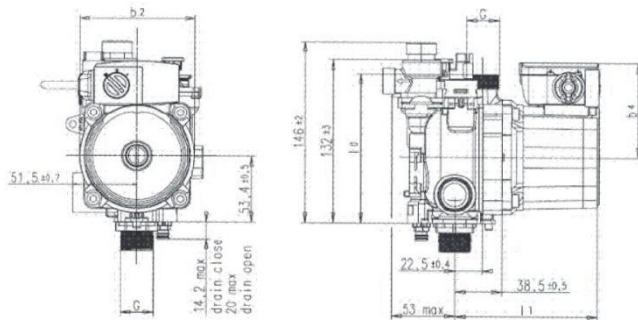

Image: Pump Wilo MSL

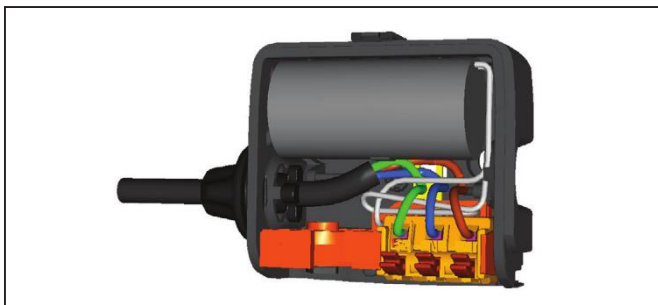

Image: Connecting the pump power cable

11.3 Mikoterm GPA15-7.5 III Pro Z178 High efficiency pump

Power at different control modes

Head	5m	6m	7m	7.5m
Power	33W	39W	52W	60W

- Energy efficiency index
EEI≤0.20-part3 (motor housing material: **bronze**)
- Power supply: 230V, 50Hz single phase AC power
- Maximal system pressure: ≤0.3MPa
- Insulation class: H
- Protect class: IP44
- Operation ambient temperature: 0°C~70°C
- Delivered liquid temperature: 2°C~95°C

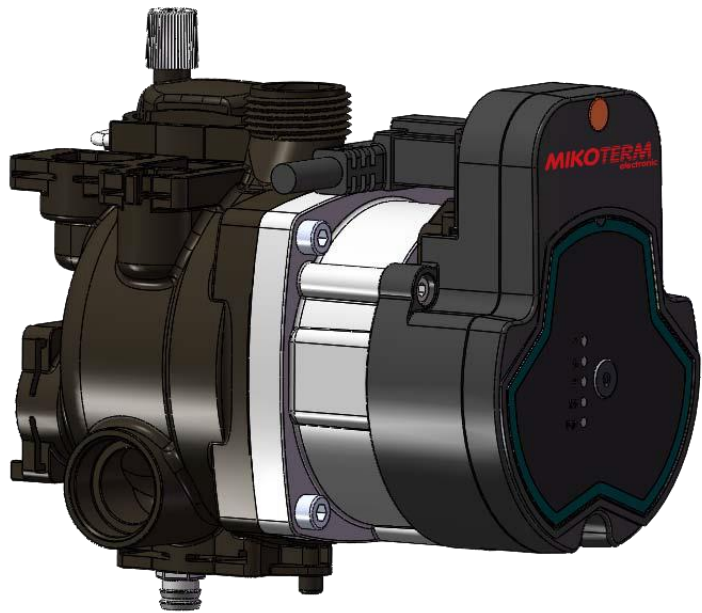

Failure code

The green light flicks by failure.

Failure code	Failure description
The gear light flashes once	Over voltage protection, re-start the pump after voltage resumes normal (over voltage setting: 270±5V).
Gear light blinks 2 times	Under voltage protection, re-start the pump after voltage resumes normal (under voltage setting: 165±5V).
Gear light blinks 3 times	Over-current protection, re-start the pump after 8s.
Gear light blinks 4 times	Phase loss protection, re-start the pump after 8s.
Gear light blinks 5 times	Block protection, re-start the pump after 8s.
Gear light blinks 6 times	Light-load protection, re-start the pump after 8s.
Gear light blinks 7 times	Over-temperature protection, re-start the pump after ambient temperature resumes to operation range for 5s
	Overheat protection, in the rated voltage, frequency, high temperature environment, high temperature water operation, IPM module surface temperature is higher than 120 ± 5 °C, the pump is reduced to 0.5 times of rated power operation, the temperature is lower than 115 ± 5 °C, the pump returns to normal operation.

Note: By failure the power should be switched off, in order to check out the failure. After troubleshooting turn on the switch and re-start the pump.

Flow-head curves

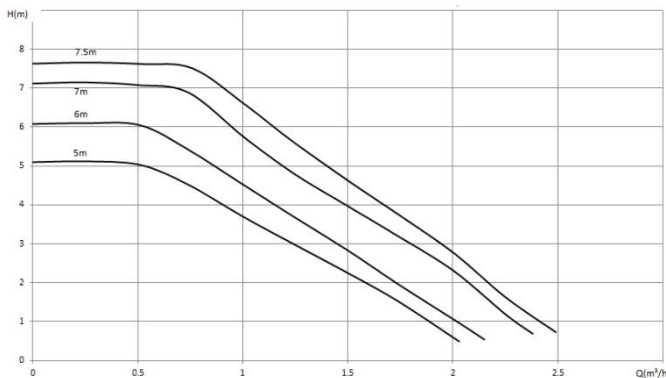

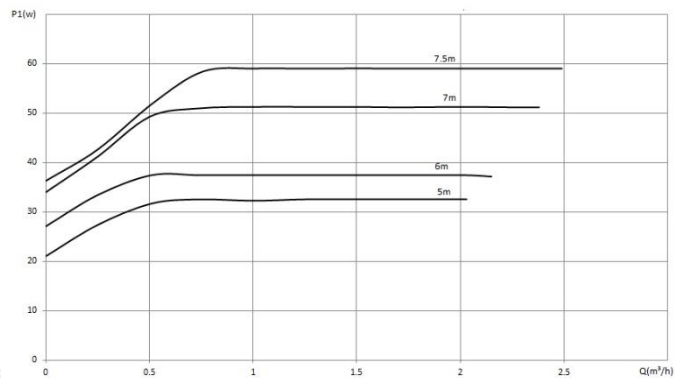

Flow-power curves



12. Product data sheet (in accordance with EU regulation no. 811/2013)

1.	Manufacturer		MIKOTERM DOO
2.	Brand name		Centrometal – EI-Cm Classic
3.	Models	I	EI-Cm Classic 4,5kW
		II	EI-Cm Classic 6kW
		III	EI-Cm Classic 9kW
		IV	EI-Cm Classic 12kW
		V	EI-Cm Classic 15kW
		VI	EI-Cm Classic 18kW
		VII	EI-Cm Classic 24kW
		VIII	EI-Cm Classic 27kW

				I	II	III	IV	V	VI	VII	VIII
4.	Room heating: Seasonal energy-efficiency class			D	D	D	D	D	D	D	D
5.	Room heating: Nominal heat output(*8) (*11)	P_{rated}	kW	4,5	6	9	12	15	18	24	27
6.	Room heating: Seasonal energy efficiency(*8)	η_s	%	37,19	37,39	37,55	37,66	37,70	37,76	37,82	37,84
7.	Annual energy consumption(*8)	Q_{HE}	kWh	5600	6600	11022	13266	19620	22088	28756	32090
8.	Sound power level, indoor	$L_{WA, indoor}$	dB(A)	32	32	35	35	41	41	41	41
9.		All specific precautions for assembly, installation and maintenance are described in the operating and installation instructions. Read and follow the operating and installation instructions.									
10.		All of the data that is included in the product information was determined by applying the specifications of the relevant European directives. Differences to product information listed elsewhere may result in different test conditions. Only the data that is contained in this product information is applicable and valid.									

(*8) For average climatic conditions

(*11) For boilers and combination boilers with a heat pump, the nominal heat output " P_{rated} " is the same as the design load in heating mode " $P_{designh}$ ", and the nominal heat output for an auxiliary boiler " P_{sup} " is the same as the additional heating output " $sup(T_j)$ "

Centrometal d.o.o.

Glavna 12
40306 MACINEC
HRVATSKA Croatia
tel: +385 (0)40 372 600
email: komercijala@centrometal.hr

This document is owned by CENTROMETAL d.o.o. and any duplication and copying of these are punishable by law. The contents of the technical documentation and technical solutions contained in this manual are protected by the intellectual property of CENTROMETAL d.o.o. Any unauthorized use, copying or publishing, in whole or in part, by other entities without the approval of CENTROMETAL d.o.o. is punishable by law.

CENTROMETAL does not assume any responsibility for possible errors in this booklet created by printing or duplicating, all images and schematics are, in principle, needed to be adapted to the actual situation on the ground. In any case, CENTROMETAL reserves the right to make changes as it deems necessary on its products.