

Centrometal

HEATING TECHNIQUE

Centrometal d.o.o. - Glavna 12, 40306 Macinec, Croatia, tel: +385 40 372 600, fax: +385 40 372 611

Technical manual

for installation, use and maintenance
of heat pump

R32

ENG

CE



Heat pumps Arctic Split series

CONTENTS

Part 1 General Information.....	3
Part 2 Engineering Data.....	10
Part 3 Installation and Field Settings.....	34

Part 1

General Information

1 System Configurations	4
2 Unit Capacities	5
3 Nomenclature	6
4 System Design and Unit Selection	8

1 System Configurations

Centrometal Split heat pumps can be configured to run with the electric heater either enabled or disabled and can also be used in conjunction with an auxiliary heat source such as a boiler.

The chosen configuration affects the size of heat pump that is required. Three typical configurations are described below. Refer to Figure 1-1.1

Configuration 1: Heat pump only

- The heat pump covers the required capacity and no extra heating capacity is necessary.
- Requires selection of larger capacity heat pump and implies higher initial investment.
- Ideal for new construction in projects where energy efficiency is paramount.

Configuration 2: Heat pump and backup electric heater

- Heat pump covers the required capacity until the ambient temperature drops below the point at which the heat pump is able to provide sufficient capacity. When the ambient temperature is below this equilibrium point (as shown in Figure 1-1.1), the backup electric heater supplies the required additional heating capacity.
- Best balance between initial investment and running costs, results in lowest lifecycle cost.
- Ideal for new construction.

Configuration 3: Heat pump conjunction with auxiliary heat source

- Heat pump covers the required capacity until the ambient temperature drops below the point at which the heat pump is able to provide sufficient capacity. When the ambient temperature is below this equilibrium point (as shown in Figure 1-1.1), depending on the system settings, either the auxiliary heat source supplies the required additional heating capacity or the heat pump does not run and the auxiliary heat source covers the required capacity.
- Enables selection of lower capacity heat pump.
- Ideal for refurbishments and upgrades.

Figure 1-1.1: System configurations

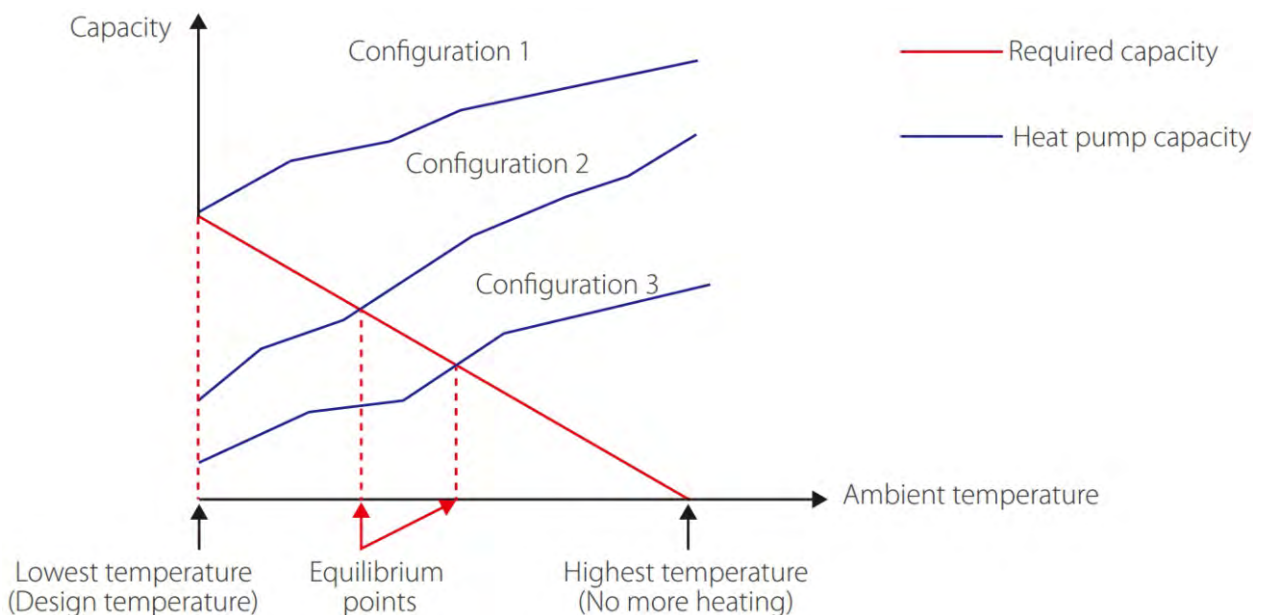

2 Unit Capacities

2.1 Outdoor unit

Table 1-2.1: Outdoor unit

Capacity	6 kW
Model	SHPAO6RP24CM
Power supply (V/Ph/Hz)	220-240/1/50
Appearance	

Capacity	10 kW	16 kW
Model	SHPAO10RP24CM	SHPAO16RP24P3CM
Power supply (V/Ph/Hz)	220-240/1/50	380-415/3/50
Appearance		

2.2 Hydronic box

Table 1-2.2: Hydronic box

Model	SHPAI60RP24CM SHPAI60RP24CM-EH	SHPAI100RP24CM SHPAI100RP24CM-EH	SHPAI160RP24CM SHPAI160RP24CM-EH
Power supply (V/Ph/Hz)	220-240/1/50	220-240/1/50	220-240/1/50 380-415/3/50
Compatible outdoor unit model	SHPAO6RP24CM	SHPAO10RP24CM	SHPAO16RP24P3CM
Appearance			

3 Nomenclature

3.1 Outdoor unit

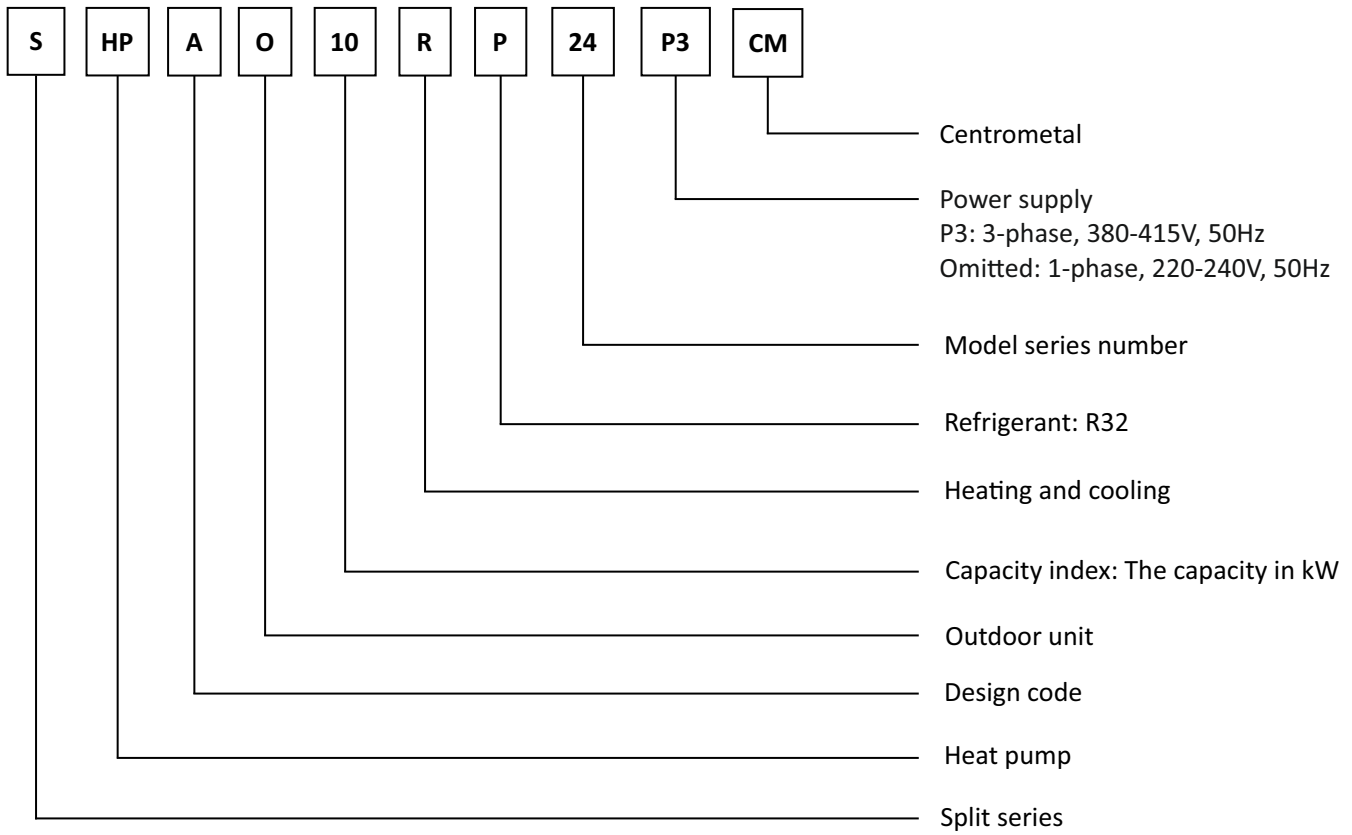

3.2 Hydronic box

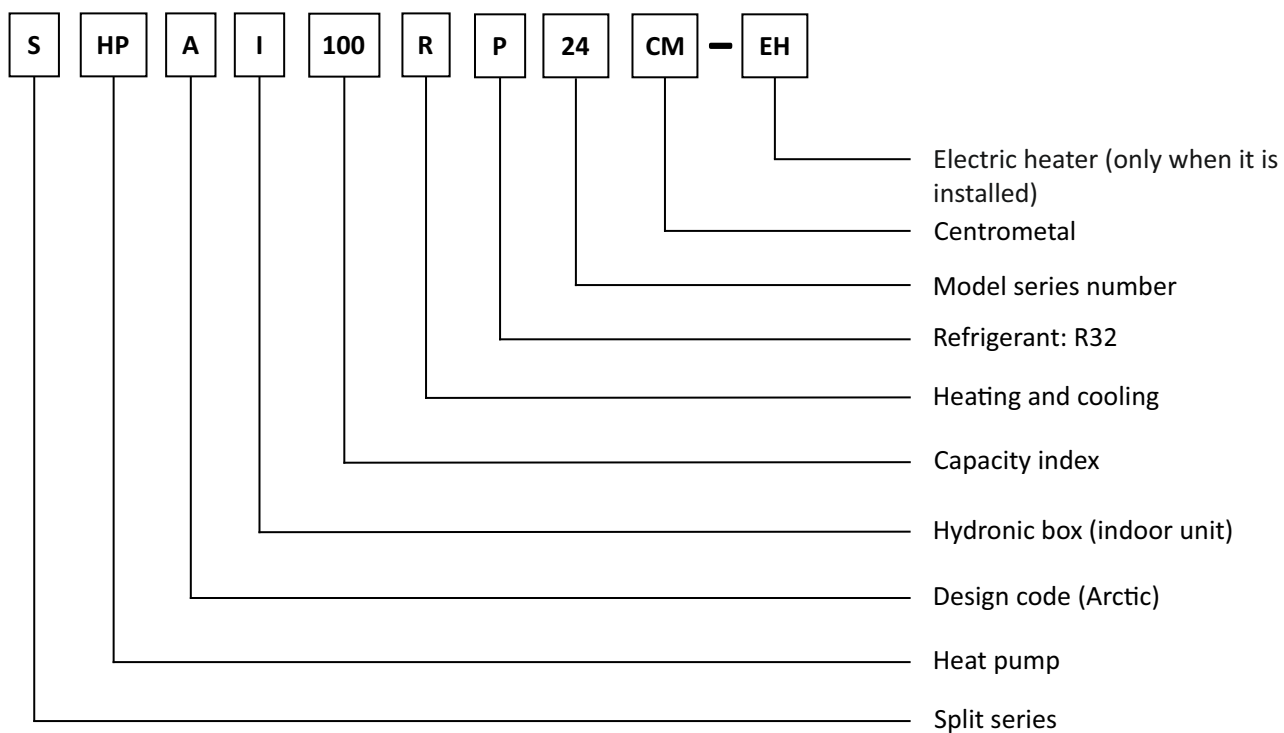

4 System Design and Unit Selection

4.1 Selection procedure

Step 1: Total heat load calculation

Calculate total heat losses of the building.
Select the heat emitters (type, quantity, water temperature and heat load).

Step 2: System configuration

Decide whether to include AHS and set AHS's switching temperature.
Decide whether backup electric heater is enabled or disabled.

Step 3: Selection of outdoor units

Determine required total heat load on outdoor units.
Set capacity safety factor.
Select power supply.

Provisionally select Centrometal heat pump Split unit capacity based on nominal capacity.

Correct capacity of the outdoor units for the following items:
Outdoor air temperature / Outdoor humidity / Water outlet temperature¹ /
Altitude / Anti-freeze fluid

Is corrected heat pump Split unit capacity \geq Required total heat load on outdoor units².

Yes

Heat pump Split system selection is complete.

No

Select a larger model or enable backup electric heater operation.

- Notes:
1. If the required water temperatures of the heat emitters are not all the same, the Centrometal heat pump Split's outlet water temperature setting should be set at the highest of the heat emitter required water temperatures. If the water outlet design temperature falls between two temperatures listed in the outdoor unit's capacity table, calculate the corrected capacity by interpolation.
 2. If the outdoor unit selection is to be based on total heating load and total cooling load, select Split units which satisfy both total heating and cooling load requirements.

4.2 Heat Pump Leaving Water Temperature (LWT) Selection

The recommended design LWT ranges for different types of heat emitter are:

- For floor heating: 30 to 35°C
- For fan coil units: 30 to 45°C
- For low temperature radiators: 40 to 50°C

4.3 Optimizing System Design

To get the most comfort with the lowest energy consumption with heat pump, it is important to take account of the following considerations:

- Choose heat emitters that allow the heat pump system to operate at as low a hot water temperature as possible whilst still providing sufficient heating.
- Make sure the correct weather dependency curve is selected to match the installation environment (building structure, climate) as well as ender user's demands.
- Connecting room thermostats (field supplied) to the hydronic system helps prevent excessive space heating by stopping the outdoor unit and circulator pump when the room temperature is above the thermostat set point.

4.4 Selection of the buffer tank and DHW tank

4.4.1 Selection of the buffer tank

The heat pump must be connected to the buffer tank in order to satisfy the minimum amount of water in the system. The volume of the buffer tank must be selected according to table 1-2.3.

Table 1-2.3: Minimum buffer tank volume

Model	Buffer tank [L]
6-10 kW	≥25
16 kW	≥40
Cascade	≥40*n

n = number of heat pumps in cascade

4.4.2 Selection of the DHW tank

The heat pump can be connected to the DHW tank. The tank can be with or without a built-in electric heater. The electric heater of the DHW tank must be installed below the tank temperature sensor. The tank temperature sensor must be above the heat exchangers in the tank. For the correct operation of the DHW heating system with a heat pump, it is necessary to comply with the minimum requirements of the DHW tank given in table 1-2.4.

Table 1-2.4: Minimum requirements of the DHW tank

Model		6 kW	10 kW	16 kW
DHW tank volume [L]	Recommended	100-250	150-300	200-500
Heat exchanger area - stainless steel coil [m ²]	Minimum	1,4	1,4	1,6
Heat exchanger area - enamel coil [m ²]	Minimum	2,0	2,0	2,5

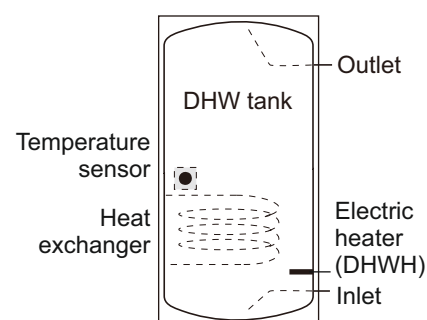

Part 2

Engineering Data

1 Specifications	11
2 Dimensions and Center of Gravity	15
3 Piping Diagrams	18
4 Wiring Diagrams	20
5 Capacity tables	23
6 Operating Limits	29
7 Hydronic Performance	30
8 Sound Levels	31
9 Accessories	33

1 Specifications

1.1 Outdoor Unit

Table 2-1.1: SHPAO6(10)RP24CM specifications¹

Model name			SHPAO6RP24CM	SHPAO10RP24CM
Compatible hydronic box			SHPAI60RP24CM(-EH)	SHPAI100RP24CM(-EH)
Power supply		V/Ph/Hz	220-240/1/50	
Heating (A7W35)	Capacity	kW	6.20	10.0
	Rated input	kW	1.24	2.00
	COP		5.00	5.00
Heating (A7W45)	Capacity	kW	6.35	10.0
	Rated input	kW	1.69	2.63
	COP		3.75	3.80
Heating (A7W55)	Capacity	kW	6.00	9.50
	Rated input	kW	2.00	3.06
	COP		3.00	3.10
Heating (A-7W35)	Capacity	kW	6.10	8.25
	Rated input	kW	2.00	2.62
	COP		3.05	3.15
Heating (A-7W55)	Capacity	kW	5.15	6.85
	Rated input	kW	2.58	3.43
	COP		2.00	2.00
Cooling (A35W18)	Capacity	kW	6.55	10.00
	Rated input	kW	1.34	2.08
	EER		4.90	4.80
Cooling (A35W7)	Capacity	kW	7.00	8.20
	Rated input	kW	2.33	2.48
	EER		3.00	3.30
Seasonal space heating energy efficiency class	LWT at 35°C		A+++	A+++
	LWT at 55°C		A++	A++
SCOP	Warmer climate	35°C	6.57	7.09
		55°C	4.21	4.62
	Average climate	35°C	4.95	5.20
		55°C	3.52	3.47
	Colder climate	35°C	4.21	4.32
		55°C	2.85	2.99
SEER	LWT at 7°C		5.34	5.98
	LWT at 18°C		8.21	8.78
MOP (Maximum overcurrent protection)		A	18	19
MCA (Minimum circuit amps)		A	14	17
Rated water flow		m ³ /h	1.07	1.72
Compressor	Type		Twin rotary DC inverter	Twin rotary DC inverter
Outdoor fan	Motor type		Brushless DC motor	Brushless DC motor
	Number of fans		1	1
Air side heat exchanger	Type		Finned tube	Finned tube
Refrigerant (R32)	Factory charge	kg	1.50	1.65
Throttle type			Electronic expansion valve	Electronic expansion valve
Piping connections	Type		Flare	Flare
	Liquid Dia.(OD)	mm	Φ6.35	Φ9.52
	Gas Dia.(OD)	mm	Φ15.9	Φ15.9
	Min. pipe length	m	2	2
	Max. pipe length	m	30	30

Installation height difference	Outdoor unit above	m	20	20
	Outdoor unit below	m	20	20
Sound power level		dB	58	60
Sound pressure level ⁹		dB	45	49
Net dimensions (W×H×D)		mm	1008×712×426	1118×865×523
Packed dimensions (W×H×D)		mm	1065×800×485	1180×890×560
Net/Gross weight		kg	58/64	77/88
Operating temperature range	Cooling	°C	-5 to 43	
	Heating	°C	-25 to 35	
	DHW	°C	-25 to 43	

Notes:

1. Relevant EU standards and legislation: EN14511; EN14825; EN50564; EN12102; (EU) No 811:2013; (EU) No 813:2013; OJ 2014/C 207/02:2014.
2. Test standard: EN12102-1.
3. Sound pressure level is the maximum value tested under the two conditions of Heating: A7W35 and Cooling: A35W18.

Table 2-1.1: SHPAO16RP24P3CM specifications¹

Model name			SHPAO16RP24P3CM	
Compatible hydronic box			SHPAI160RP24CM(-EH)	
Power supply		V/Ph/H	380-415/3/50	
Heating (A7W35)	Capacity	kW	16.0	
	Rated input	kW	3.56	
	COP		4.50	
Heating (A7W45)	Capacity	kW	16.0	
	Rated input	kW	4.44	
	COP		3.60	
Heating (A7W55)	Capacity	kW	16.0	
	Rated input	kW	5.52	
	COP		2.90	
Heating (A-7W35)	Capacity	kW	13.3	
	Rated input	kW	4.93	
	COP		2.70	
Heating (A-7W55)	Capacity	kW	12.5	
	Rated input	kW	6.19	
	COP		2.02	
Cooling (A35W18)	Capacity	kW	14.90	
	Rated input	kW	4.38	
	EER		3.40	
Cooling (A35W7)	Capacity	kW	14.0	
	Rated input	kW	5.71	
	EER		2.45	
Seasonal space heating energy efficiency class	LWT at 35°C		A+++	
	LWT at 55°C		A++	
SCOP	Warmer climate	35°C	6.28	
		55°C	4.47	
	Average climate	35°C	4.62	
		55°C	3.41	
	Colder climate	35°C	4.02	
		55°C	3.12	
SEER	LWT at 7°C		4.67	
	LWT at 18°C		6.71	
MOP (Maximum overcurrent protection)		A	14	
MCA (Minimum circuit amps)		A	12	
Rated water flow		m ³ /h	2.75	
Compressor	Type		Twin rotary DC inverter	
Outdoor fan	Motor type		Brushless DC motor	
	Number of fans		1	
Air side heat exchanger	Type		Finned tube	
Refrigerant (R32)	Factory charge	kg	1.84	
Throttle type			Electronic expansion valve	
Piping connections	Type		Flare	
	Liquid / Gas Dia. (OD)	mm	Ø9.52/15.9	
	Min. / Max. pipe length		m	2/30
Installation height diff.	Outdoor unit above/below		m	20
Sound power level		dB	68	
Sound pressure level (1m) ²		dB	55	
Net dimensions (W×H×D)		mm	1118×865×523	
Packed dimensions (W×H×D)		mm	1180×890×560	

Net/Gross weight		kg	112/125
Operating temperature range	Cooling	°C	-5 to 43
	Heating	°C	-25 to 35
	DHW	°C	-25 to 43

Note:

1. Relevant EU standards and legislation: EN14511; EN14825; EN50564; EN12102; (EU) No 811:2013; (EU) No 813:2013; OJ 2014/C 207/02:2014.
2. Test standard: EN12102-1.
3. Sound pressure level is the maximum value tested under the two conditions of Heating: A7W35 and Cooling: A35W18.

1.2 Hydronic Box

Table 2-1.2: SHPAI60(100,160)RP24CM(-EH) specifications

Model name			SHPAI60RP24CM(-EH)	SHPAI100RP24CM(-EH)	SHPAI160RP24CM(-EH)	
Compatible outdoor unit model			SHPAO6RP24CM	SHPAO10RP24CM	SHPAO16RP24P3CM	
Function			Heating and cooling			
Setting water temperature range	Cooling	°C	5 to 25			
	Heating	°C	25 to 65			
	DHW ³	°C	30 to 60			
Power supply		V/Ph/Hz	220-240/1/50	220-240/1/50	220-240/1/50 380-415/3/50 ⁴	
Sound power level ¹		dB	38	42	43	
Sound pressure level (1m) ²		dB	28	30	32	
Dimension (W×H×D)		mm	420×790×270	420×790×270	420×790×270	
Packing (W×H×D)		mm	525×1050×360	525×1050×360	525×1050×360	
Net/gross weight		kg	37/43	37/43	39/45	
Water circuit	Piping connections		inch	R1"	R1"	R1"
	Safety valve set pressure		MPa	0.3	0.3	0.3
	Drainage pipe connection		mm	Φ25	Φ25	Φ25
	Expansion tank	Volume	L	8.0	8.0	8.0
		Max. water pressure	MPa	0.3	0.3	0.3
		Pre-pressure	MPa	0.1	0.1	0.1
	Water side exchanger	Type		Plate type	Plate type	Plate type
	Water pump head		m	9	9	9
Water flow range		m ³ /h	0.4~1.25	0.4~2.10	0.70~3.00	
Internal water volume		L	5.0	5.0	5.0	
Refrigerant circuit	Liquid Dia. (OD)		mm	Φ6.35	Φ9.52	Φ9.52
	Gas Dia. (OD)		mm	Φ15.9	Φ15.9	Φ15.9

Notes:

1. Test standard: EN12102-1.
2. Sound pressure level is the maximum value tested under the two conditions of Heating: A7W35 and Cooling: A35W18 for different combination between outdoor unit and hydronic box.
3. Maximum domestic hot water temperature 60°C is only available with DHW heater support.
4. Models with built in electric heater (SHPAI160RP24CM-EH)

2 Dimensions and Center of Gravity

2.1 Outdoor Unit

SHPAO6RP24CM

Figure 2-2.1: SHPAO6RP24CM dimensions and center of gravity (unit: mm)

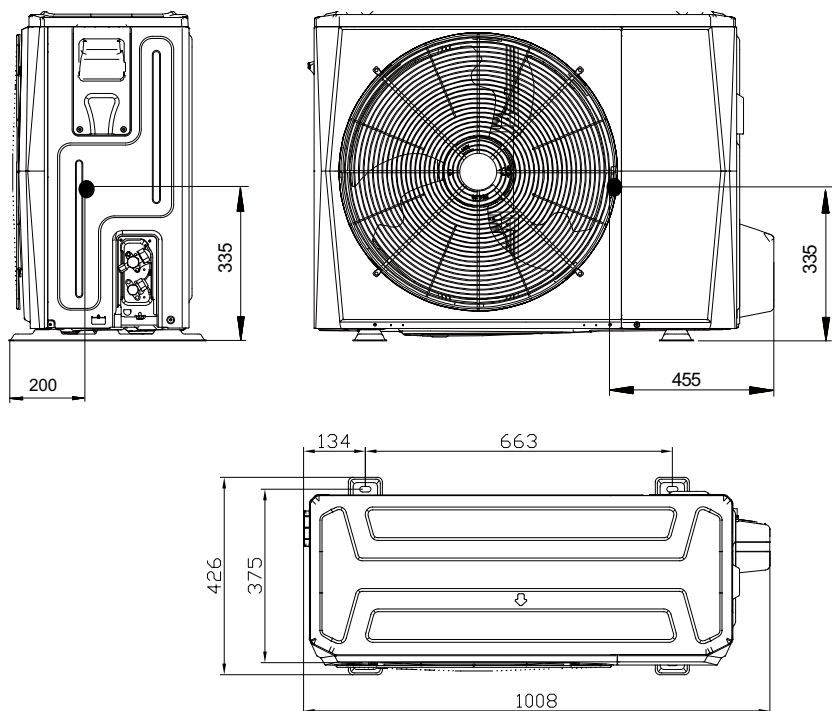

SHPAO10RP24CM

Figure 2-2.2: SHPAO10RP24CM dimensions and center of gravity (unit: mm)

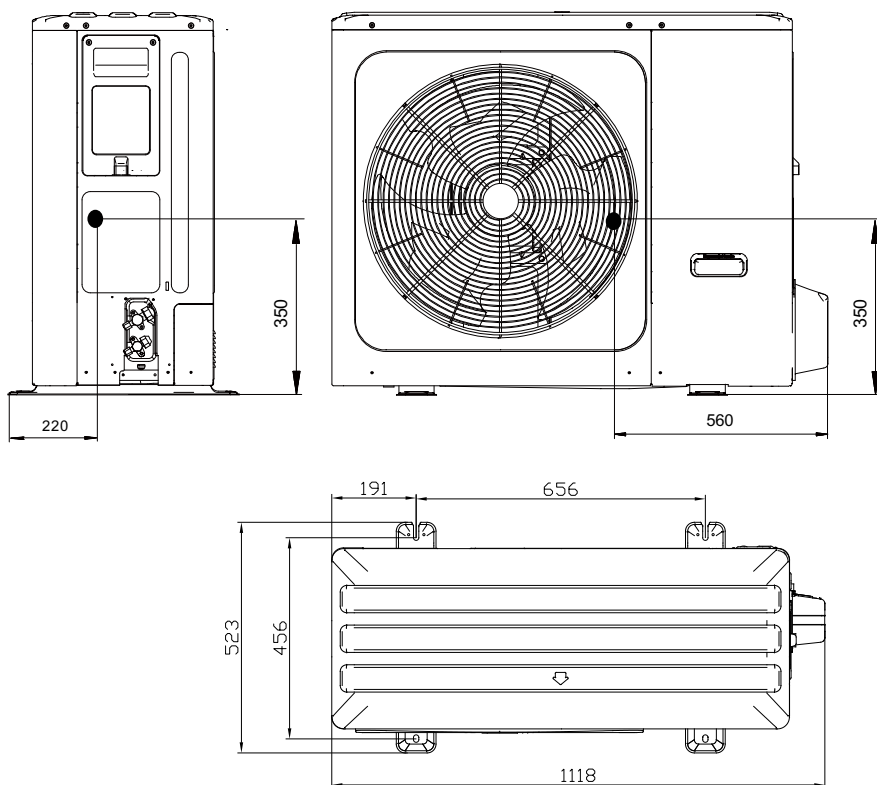

SHPAO16RP24P3CM

Figure 2-2.3: SHPAO16RP24P3CM dimensions and center of gravity (unit: mm)

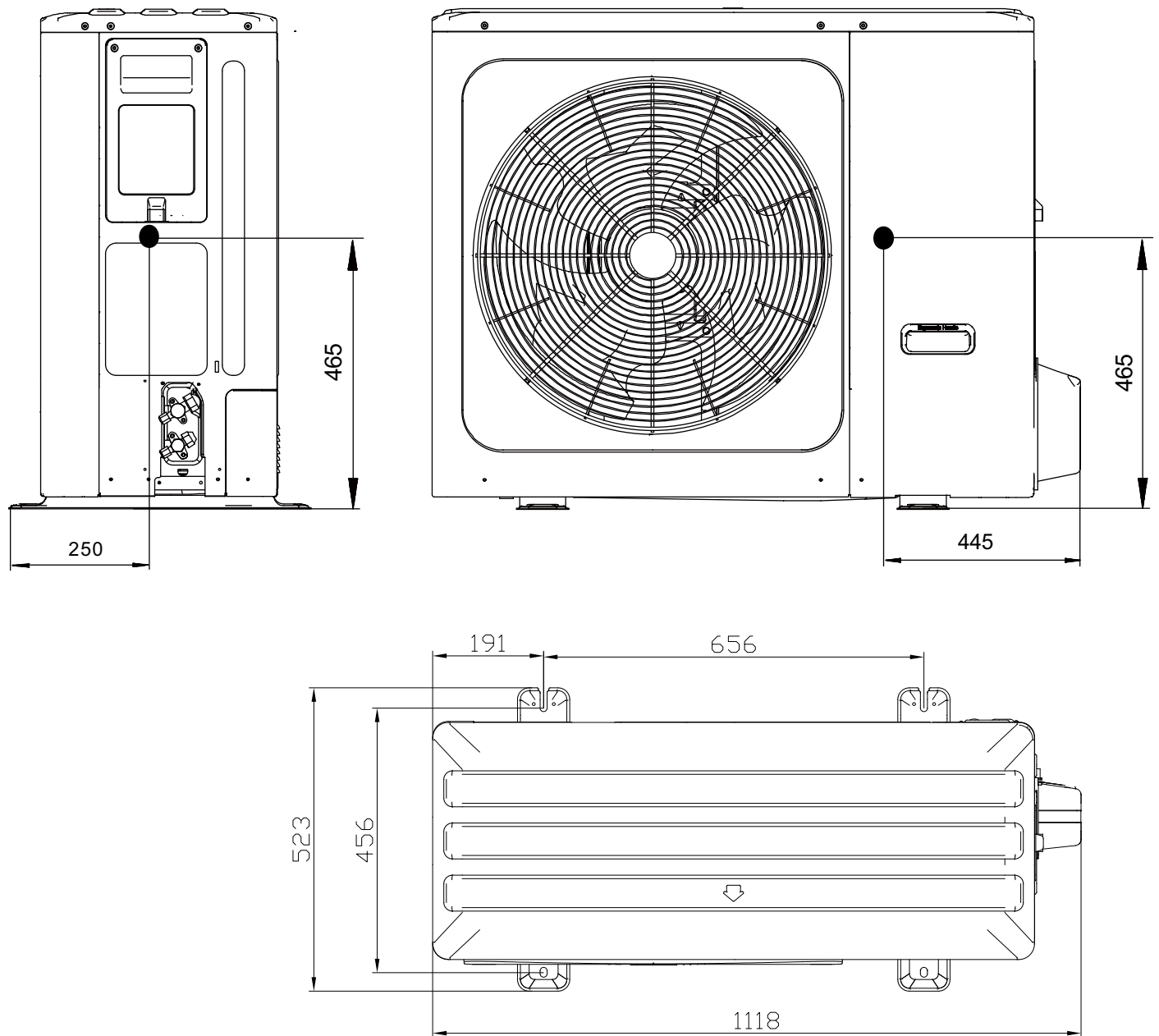

2.2 Hydronic Box

Figure 2-2.4: Hydronic box dimensions and center of gravity (unit: mm)

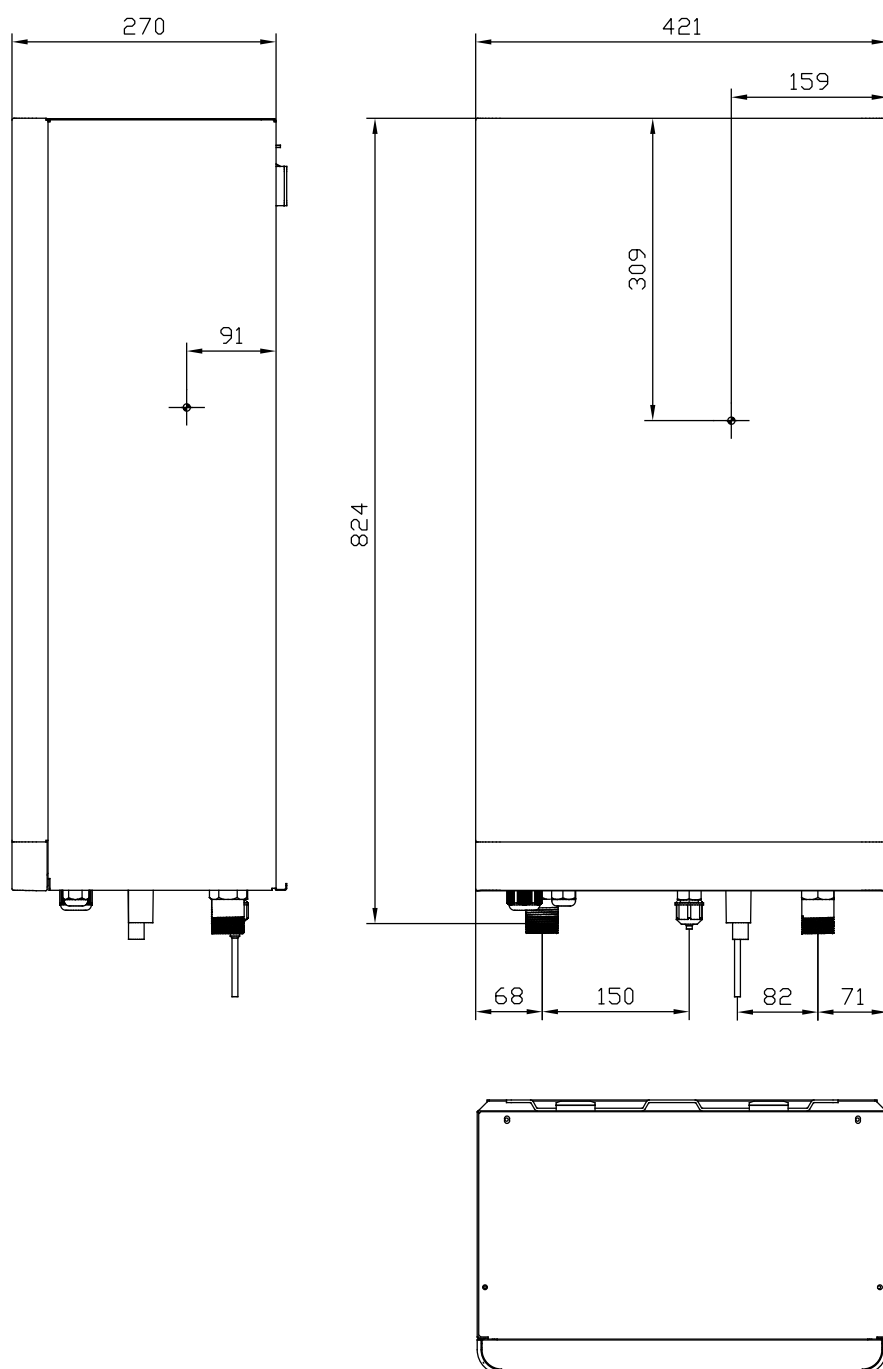

3 Piping Diagrams

3.1 Outdoor Unit

Figure 2-3.1: Outdoor unit piping diagram

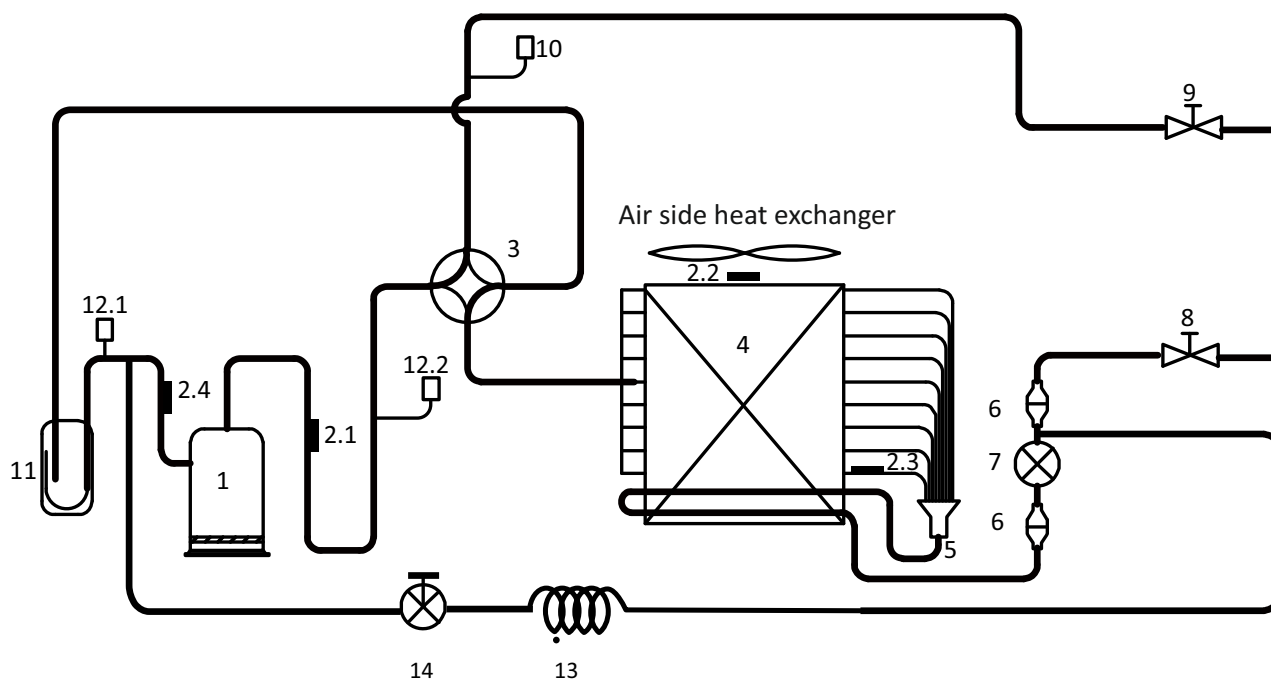

Legend			
1	Compressor	7	Electronic expansion valve
2.1	Discharge pipe temperature sensor	8	Stop valve (liquid side)
2.2	Outdoor ambient temperature sensor	9	Stop valve (gas side)
2.3	Air side heat exchanger refrigerant outlet temperature sensor	10	Pressure sensor
2.4	Suction pipe temperature sensor	11	Separator
3	4-way valve	12.1	Low pressure switch
4	Air side heat exchanger	12.2	High pressure switch
5	Distributor	13	Capillary
6	Filter	14	Solenoid valve

3.2 Hydronic Box

Figure 2-3.2: Hydronic box piping diagram

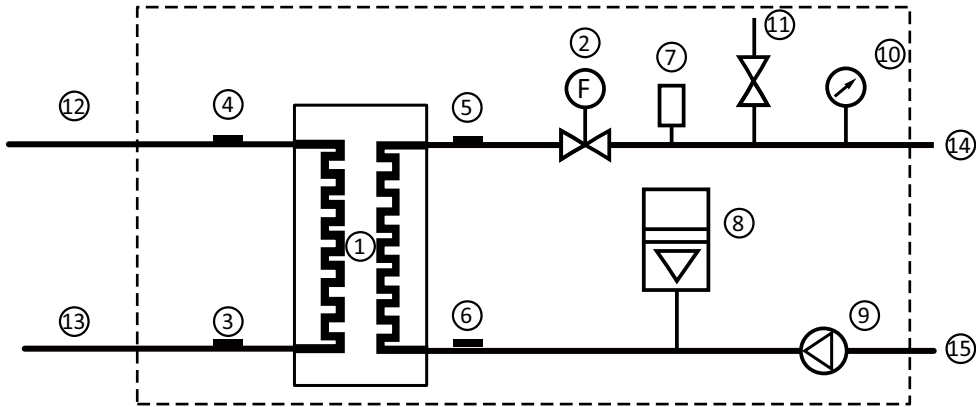

Legend			
1	Water side heat exchanger	9	Water pump
2	Water flow switch	10	Manometer
3	Refrigerant liquid line temperature sensor	11	Safety valve
4	Refrigerant gas line temperature sensor	12	Refrigerant gas side
5	Water outlet temperature sensor	13	Refrigerant liquid side
6	Water inlet temperature sensor	14	Water outlet
7	Air purge valve	15	Water inlet
8	Expansion vessel		

4 Wiring Diagrams

4.1 Outdoor Unit

SHPA06(10)RP24CM

Figure 2-4.1: SHPA06(10)RP24CM wiring diagram

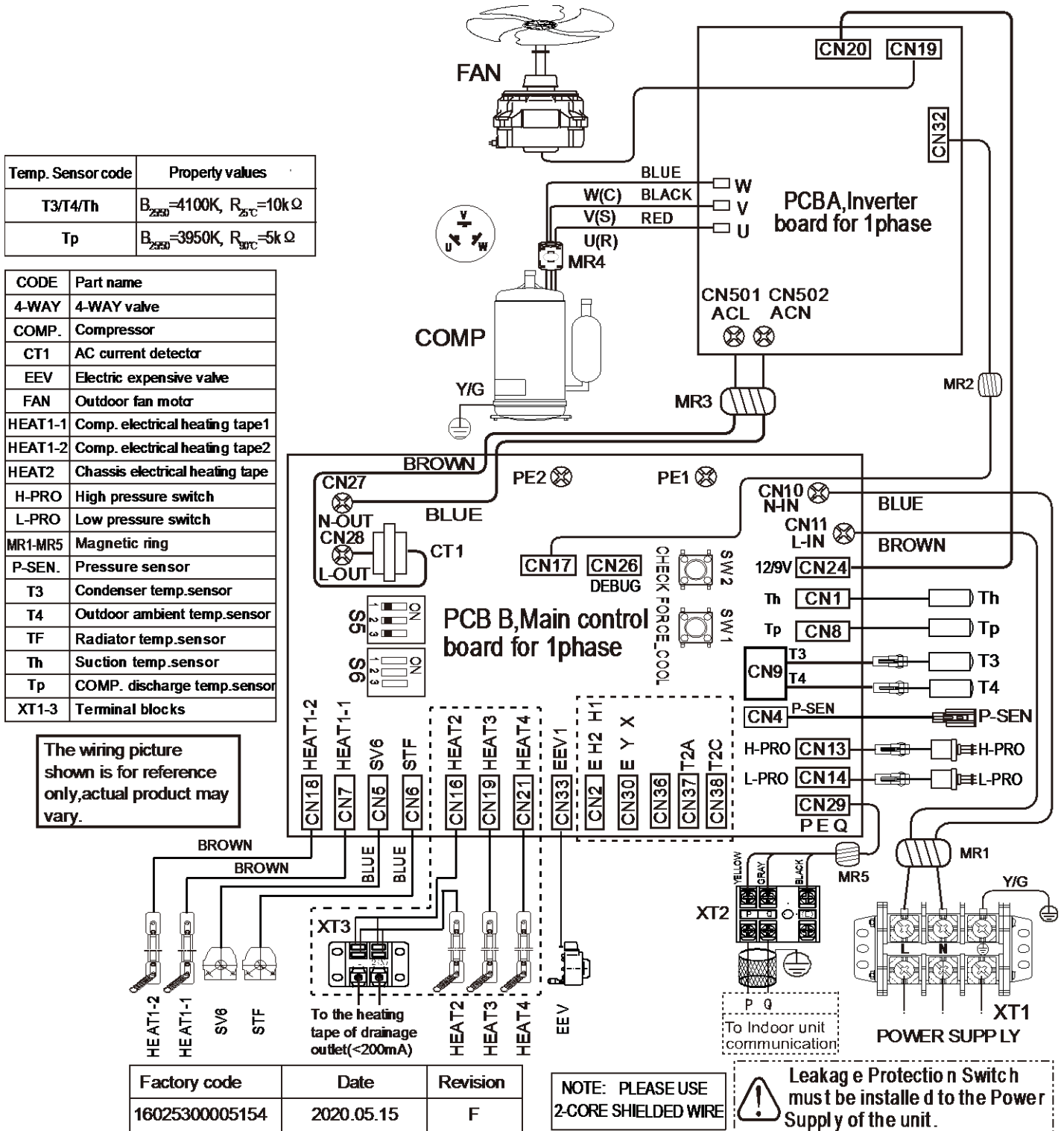

SHPAO16RP24P3CM

Figure 2-4.2: SHPAO16RP24P3CM wiring diagram

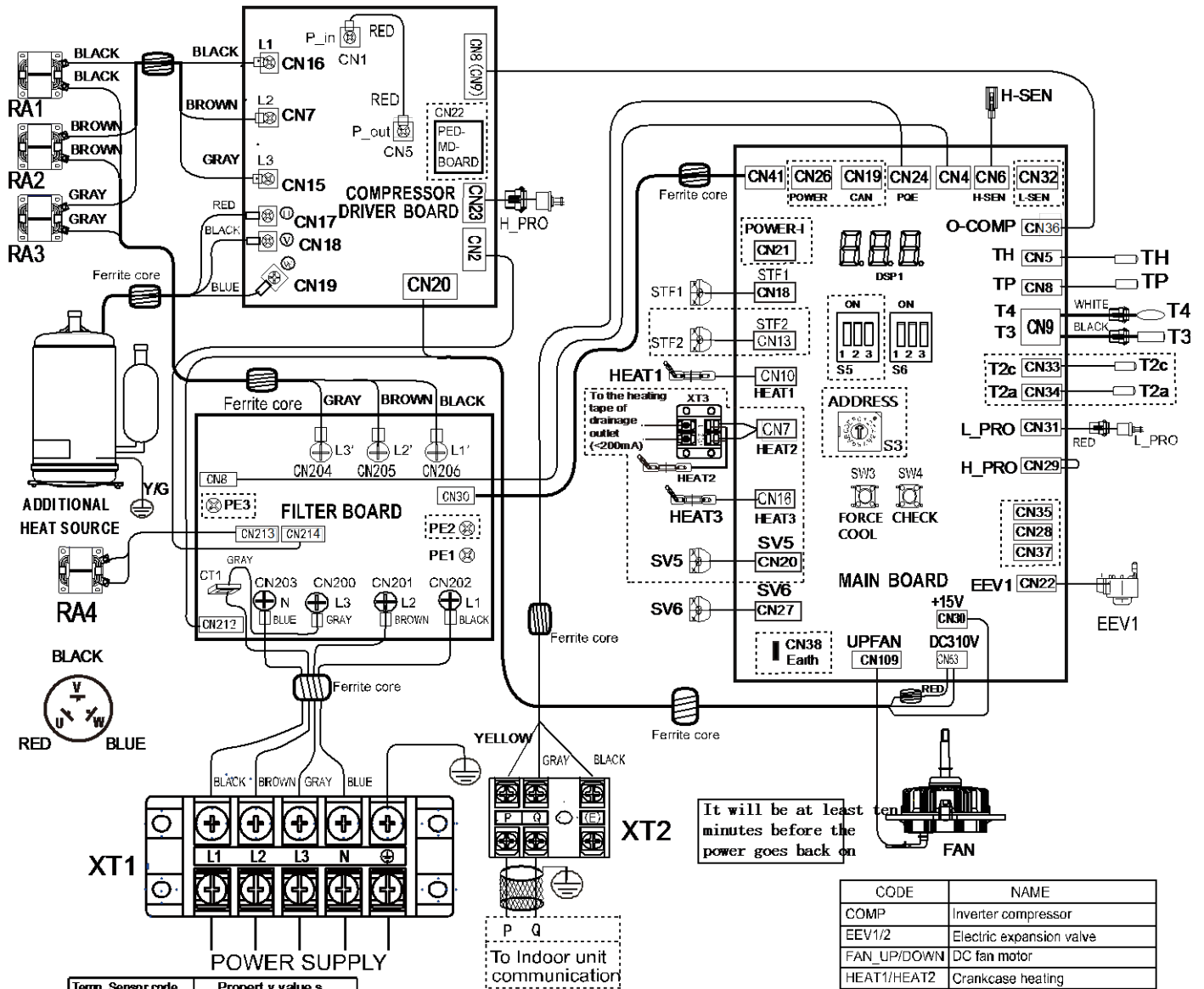

Temp. Sensor code	Property values
T3/T4/T6(Th)	$B_{2500} = 4100K, R_{25} = 10k\Omega$
T5(Tp)	$B_{3500} = 3950K, R_{25} = 5k\Omega$

Warning: Leakage Protection Switch must be installed to the Power Supply of the electric heating.

Equipment must be grounded.

The wiring picture shown is for reference only, actual product may vary.

Factory code	Date	Revision
16025300005134	2020.05.07	H

It will be at least ten minutes before the power goes back on

CODE	NAME
COMP	Inverter compressor
EEV1/2	Electric expansion valve
FAN_UP/DOWN	DC fan motor
HEAT1/HEAT2	Crankcase heating
H_PRO/L_PRO	High/Low pressure switch
H-SEN	High pressure sensor
XT1	Big 4-phase terminal
CT1	AC current transformer
RA	Reactor
STF1/STF2	4-way valve
SV5/SV6	Solenoid valve
T3/T3A	Piping temperature sensor
T4	Outdoor ambient temperature sensor
T5	Inverter compressor discharge temperature sensor
TP	Compressor exhaust temperature sensor
TH	Compressor return temperature sensor

4.2 Hydronic Box

SHPAI60(100,160)RP24CM SHPAI60(100,160)RP24CM-EH

Figure 2-4.3: SHPAI60(100,160)RP24CM(-EH) wiring diagram

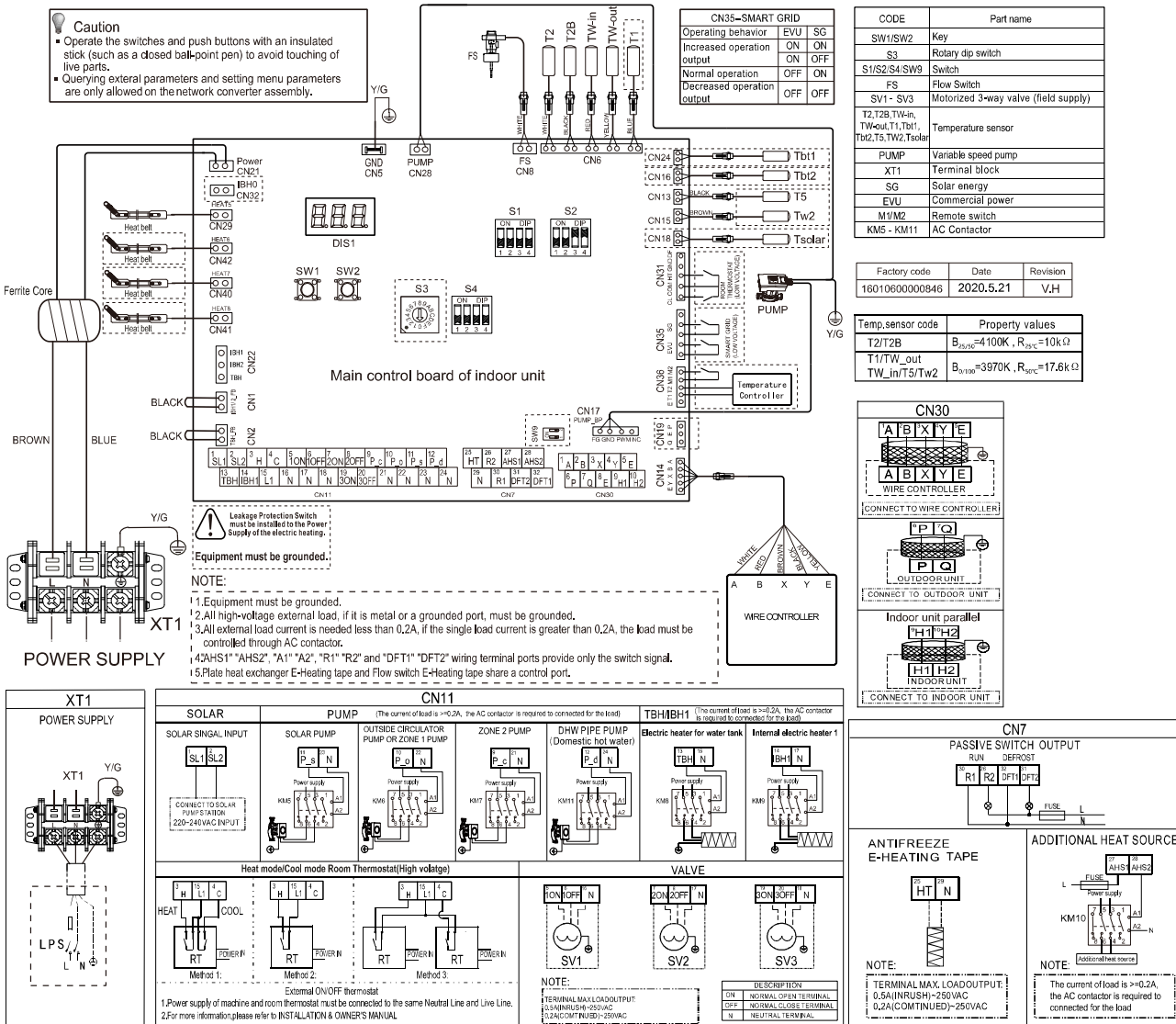

4.3 Recommended wire cross-sectional area and circuit breakers

Table 2-4.1: Outdoor unit wiring and circuit breakers

Model	Power supply (V/Ph/Hz)	Nominal cross-sectional area (mm ²)	Circuit breaker (A)/Ph
SHPAO6RP24CM	220-240/1/50	3x2.5	B16/1ph
SHPAO10RP24CM	220-240/1/50	3x2.5	B20/1ph
SHPAO16RP24P3CM	380-415/3/50	5x2.5	B16/3ph

Table 2-4.2: Hydronic box with built in electric heater wiring and circuit breakers

Model	Electric heater capacity (kW)	Power supply (V/Ph/Hz)	Nominal cross-sectional area (mm ²)	Circuit breaker (A)/Ph
SHPAI60RP24CM-EH	3	220-240/1/50	3x2.5	B20/1ph
SHPAI100RP24CM-EH	3	220-240/1/50	3x2.5	B20/1ph
SHPAI160RP24CM-EH	9	380-415/3/50	5x4.0	B32/3ph

5 Capacity Tables

5.1 Heating Capacity Tables (Test standard: EN14511)

Table 2-5.1: Heating capacity for SHPA06RP24CM

Maximum																											
DB	LWT																										
	25			30			35			40			45			50			55			60			65		
	HC	PI	COP	HC	PI	COP	HC	PI	COP	HC	PI	COP	HC	PI	COP	HC	PI	COP	HC	PI	COP	HC	PI	COP	HC	PI	COP
-25	2.57	1.49	1.72	2.25	1.53	1.46	2.14	1.67	1.28	1.91	1.64	1.17	1.71	1.57	1.09	/	/	/	/	/	/	/	/	/	/		
-20	3.64	1.56	2.34	3.34	1.86	1.80	2.88	2.03	1.42	2.56	2.08	1.23	2.33	2.08	1.12	2.19	2.04	1.07	1.84	1.86	0.99	/	/	/	/		
-15	4.43	1.49	2.97	4.19	1.53	2.73	4.00	1.71	2.34	3.61	1.87	1.93	3.08	2.01	1.53	2.70	2.02	1.34	2.26	1.88	1.20	2.13	2.02	1.05	/	/	/
-10	5.75	1.69	3.41	5.50	1.84	2.99	5.11	1.99	2.57	4.83	2.18	2.22	4.64	2.24	2.07	4.13	2.41	1.72	3.80	2.24	1.69	3.32	2.30	1.44	/	/	/
-7	6.55	1.77	3.71	6.30	1.92	3.28	6.21	2.17	2.86	5.79	2.32	2.50	5.57	2.38	2.35	5.29	2.63	2.01	5.22	2.66	1.96	4.57	2.61	1.75	/	/	/
-5	6.54	1.64	3.98	6.32	1.79	3.52	6.14	1.99	3.09	5.97	2.18	2.74	5.84	2.30	2.54	5.44	2.44	2.23	5.31	2.64	2.01	4.73	2.59	1.83	/	/	/
0	6.49	1.34	4.85	6.37	1.48	4.31	6.35	1.68	3.79	6.80	1.99	3.42	6.85	2.25	3.04	5.88	2.37	2.48	5.42	2.59	2.09	5.06	2.54	1.99	/	/	/
5	7.04	1.31	5.37	6.71	1.50	4.48	6.88	1.62	4.25	6.96	1.89	3.69	6.99	2.12	3.29	6.37	2.27	2.81	6.11	2.46	2.48	5.74	2.53	2.27	4.92	2.68	1.84
7	7.58	1.28	5.90	7.06	1.47	4.81	7.41	1.56	4.76	7.13	1.79	3.99	7.13	2.00	3.58	6.87	2.16	3.17	6.90	2.37	2.91	6.42	2.52	2.55	5.25	2.60	2.02
10	7.43	1.21	6.12	7.11	1.36	5.24	7.35	1.46	5.02	7.37	1.75	4.21	7.32	1.93	3.78	7.01	2.09	3.35	6.93	2.28	3.04	6.27	2.41	2.60	5.57	2.52	2.21
15	7.17	1.13	6.35	7.20	1.24	5.82	7.26	1.38	5.28	7.78	1.69	4.61	7.63	1.83	4.16	7.24	1.97	3.67	6.98	2.12	3.30	6.01	2.23	2.70	6.10	2.39	2.56
20	6.93	0.97	7.15	6.97	1.11	6.28	6.98	1.18	5.91	7.21	1.54	4.70	7.42	1.68	4.42	7.28	1.81	4.02	6.81	1.89	3.60	5.98	1.95	3.06	/	/	/
25	6.69	0.80	8.32	6.74	0.94	7.16	6.70	1.06	6.31	6.65	1.30	5.11	7.21	1.52	4.74	7.33	1.66	4.43	6.63	1.66	4.00	5.94	1.67	3.55	/	/	/
30	6.74	0.71	9.53	6.83	0.85	8.02	6.83	0.94	7.27	6.56	1.09	6.01	7.05	1.40	5.05	6.91	1.40	4.92	6.60	1.57	4.21	6.01	1.57	3.83	/	/	/
35	6.79	0.66	10.3	6.93	0.73	9.43	6.96	0.85	8.17	6.47	0.94	6.87	6.89	1.27	5.42	6.49	1.24	5.21	6.57	1.48	4.45	/	/	/	/	/	/
40	7.26	0.64	11.4	7.37	0.73	10.2	7.28	0.81	9.02	7.12	0.97	7.34	7.34	1.20	6.12	6.93	1.22	5.68	/	/	/	/	/	/	/	/	/
43	7.54	0.63	12.0	7.64	0.70	10.9	7.48	0.76	9.87	7.51	0.91	8.27	7.61	1.08	7.02	7.19	1.21	5.96	/	/	/	/	/	/	/	/	/
Normal																											
DB	LWT																										
	25			30			35			40			45			50			55			60			65		
	HC	PI	COP	HC	PI	COP	HC	PI	COP	HC	PI	COP	HC	PI	COP	HC	PI	COP	HC	PI	COP	HC	PI	COP	HC	PI	COP
-25	2.37	1.35	1.76	2.07	1.37	1.51	1.95	1.50	1.30	1.77	1.51	1.17	1.61	1.49	1.08	/	/	/	/	/	/	/	/	/	/	/	/
-20	3.33	1.37	2.43	3.04	1.65	1.85	2.60	1.78	1.46	2.34	1.87	1.25	2.16	1.92	1.13	2.04	1.88	1.08	1.77	1.78	1.00	/	/	/	/	/	/
-15	4.01	1.29	3.11	3.77	1.33	2.83	3.57	1.47	2.43	3.27	1.65	1.98	2.73	1.76	1.56	2.41	1.76	1.37	2.08	1.70	1.22	1.98	1.88	1.05	/	/	/
-10	5.15	1.43	3.61	4.89	1.57	3.12	4.51	1.69	2.66	4.33	1.91	2.27	4.21	2.01	2.10	3.76	2.15	1.75	3.46	2.03	1.71	3.06	2.13	1.44	/	/	/
-7	6.24	1.62	3.86	6.05	1.80	3.36	6.10	2.00	3.05	5.61	2.21	2.54	5.40	2.25	2.40	5.07	2.45	2.07	5.15	2.58	2.00	4.28	2.39	1.79	/	/	/
-5	5.89	1.40	4.20	5.64	1.54	3.66	5.26	1.64	3.21	5.26	1.81	2.90	5.10	1.93	2.64	4.31	1.87	2.30	4.28	2.06	2.07	3.94	2.12	1.86	/	/	/
0	5.99	1.20	4.98	5.80	1.31	4.43	5.74	1.47	3.89	6.26	1.81	3.47	6.06	1.92	3.15	5.36	2.12	2.53	4.75	2.24	2.12	4.46	2.24	1.99	/	/	/
5	6.43	1.16	5.56	6.06	1.31	4.64	6.16	1.39	4.42	6.36	1.68	3.78	6.13	1.78	3.45	5.76	1.99	2.89	5.40	2.13	2.54	5.01	2.19	2.29	4.03	2.09	1.93
7	6.75	1.09	6.18	6.30	1.21	5.21	6.20	1.24	5.00	6.44	1.55	4.14	6.35	1.69	3.75	6.13	1.86	3.29	6.00	2.00	3.00	5.64	2.17	2.60	4.40	2.06	2.14
10	6.68	1.02	6.52	6.22	1.13	5.49	6.49	1.26	5.17	6.59	1.50	4.39	6.62	1.73	3.83	6.47	1.88	3.44	6.04	1.94	3.11	5.76	2.17	2.65	4.54	1.94	2.34
15	6.52	0.94	6.93	6.37	1.02	6.24	6.48	1.16	5.57	7.03	1.43	4.92	6.98	1.61	4.32	6.76	1.75	3.86	6.15	1.80	3.42	5.59	2.00	2.79	5.04	1.82	2.77
20	6.34	0.81	7.85	6.20	0.91	6.79	6.27	1.00	6.28	6.55	1.30	5.05	6.82	1.48	4.62	6.84	1.61	4.25	6.03	1.60	3.76	5.58	1.82	3.07	/	/	/
25	5.97	0.65	9.21	6.12	0.78	7.79	6.13	0.91	6.75	6.15	1.11	5.53	6.76	1.35	4.99	7.01	1.49	4.72	5.99	1.43	4.20	5.65	1.57	3.59	/	/	/
30	6.04	0.57	10.6	6.24	0.71	8.79	6.29	0.80	7.84	6.10	0.93	6.55	6.64	1.24	5.35	6.64	1.26	5.28	6.00	1.35	4.46	5.75	1.47	3.91	/	/	/
35	6.14	0.53	11.6	6.38	0.61	10.4	6.46	0.73	8.87	6.07	0.81	7.54	6.55	1.13	5.79	6.29	1.12	5.63	6.02	1.27	4.75	/	/	/	/	/	/
40	6.66	0.52	12.9	6.67	0.59	11.3	6.57	0.67	9.86	6.49	0.80	8.11	6.78	1.03	6.59	6.53	1.06	6.19	/	/	/	/	/	/	/	/	/
43	6.97	0.51	13.7	6.98	0.57	12.2	6.80	0.63	10.9	6.91	0.75	9.20	7.09	0.93	7.61	6.84	1.05	6.54	/	/	/	/	/	/	/	/	/
Minimum																											
DB	LWT																										
	25			30			35			40			45			50			55			60			65		
	HC	PI	COP	HC	PI	COP	HC	PI	COP	HC	PI	COP	HC	PI	COP	HC	PI	COP	HC	PI	COP	HC	PI	COP	HC	PI	COP
-25	1.54	0.86	1.78	1.39	0.91	1.53	1.48	1.12	1.32	1.36	1.14	1.19	1.08	0.99	1.09	/	/	/	/	/	/	/	/	/	/	/	/
-20	2.04	0.82	2.47	1.80	0.96	1.88	1.67	1.12	1.49	1.64	1.28	1.28	1.45	1.27	1.14	1.51	1.38	1.09	1.34	1.34	1.01	/	/	/	/	/	/
-15	2.07	0.65	3.18	2.03	0.70	2.90	1.90	0.76	2.49	2.02	0.99	2.03	1.97	1.25	1.58	1.86	1.35	1.39	1.53	1.24	1.24	1.51	1.41	1.07	/	/	/
-10	2.28	0.62	3.71	2.14	0.67	3.21	2.02	0.74	2.74	2.51	1.07	2.34	2.81	1.32	2.14	2.80	1.57	1.78	2.63	1.51	1.74	2.38	1.63	1.47	/	/	/
-7	1.57	0.39	4.03	1.45	0.41	3.50	1.48	0.48	3.06	2.49	0.92	2.72	2.67	1.08	2.48	2.57	1.22	2.11	2.64	1.31	2.01	2.68	1.47	1.82	/	/	/
-5	1.78	0.41	4.32	1.66	0.44	3.76	1.70	0.52	3.30	2.59	0.87	2.98	2.82	1.05	2.69	2.59	1.10	2.35	2.81	1.33	2.11	2.72	1.43	1.90	/	/	/
0	1.74	0.34	5.15	1.82	0.40	4.58	1.77	0.44	4.02	2.93	0.82	3.59	3.02	0.93	3.23	2.99	1.15	2.59	2.85	1.31	2.17	3.00	1.47	2.04	/	/	/
5	2.31	0.40	5.78	2.32	0.48	4.82	2.33	0.51	4.59	3.21	0.82	3.93	3.29	0.93	3.54	3.43	1.15	2.98	3.46	1.32	2.62	3.58	1.52	2.36	2.85	1.42	2.01
7	2.71	0.42	6.44	2.65	0.49	5.37	2.73	0.53	5.32	3.36	0.78	4.32	3.85	0.99	3.88	4.26	1.25	3.41	4.38	1.41	3.10	4.23	1.57	2.69	3.33	1.49	2.24
10	2.27	0.33	6.83	2.08	0.36	5.75	2.32	0.43	5.42	3.32	0.72	4.60	3.96	0.99	3.99	4.22	1.18	3.57	4.37	1.35	3.23	4.20	1.53	2.75	3.55	1.46	2.43
15	2.81	0.38	7.31	2.83	0.43	6.59	2.84	0.48	5.89	3.60	0.69	5.20	4.22	0.93	4.53	4.46	1.10	4.05	5.03	1.40	3.58	4.39	1.56	2.82	3.84	1.33	2.90
20	3.12	0.38	8.30	3.41	0.48	7.18	3.70	0.56	6.65	4.54	0.85	5.34	4.60	0.95	4.86	4.73	1.06	4.46	4.56	1.15	3.95	4.00	1.24	3.23	/	/	/
25	3.68	0.38	9.73	3.97	0.48	8.24	4.22	0.59	7.15	4.85	0.83	5.85	5.19	0.													

Part 2

Table 2-5.2: Heating capacity for SHPAO10RP24CM

Maximum																													
DB	LWT																												
	25			30			35			40			45			50			55			60			65				
	HC	PI	COP	HC	PI	COP	HC	PI	COP	HC	PI	COP	HC	PI	COP	HC	PI	COP	HC	PI	COP	HC	PI	COP	HC	PI	COP		
-25	4.68	2.06	2.27	4.21	2.12	1.98	3.78	2.28	1.66	3.52	2.24	1.57	2.96	2.26	1.31	/	/	/	/	/	/	/	/	/	/	/			
-20	5.98	2.12	2.82	5.35	2.24	2.39	4.98	2.34	2.13	4.55	2.55	1.79	3.89	2.39	1.63	3.34	2.35	1.42	2.75	2.18	1.26	/	/	/	/	/			
-15	7.26	2.15	3.37	6.78	2.34	2.90	6.43	2.62	2.46	5.86	2.57	2.28	5.57	2.76	2.02	4.91	2.82	1.74	5.20	3.04	1.71	4.20	2.96	1.42	/	/			
-10	8.37	2.33	3.60	8.14	2.53	3.22	7.89	2.65	2.98	7.64	2.86	2.67	7.38	3.10	2.38	7.03	3.31	2.13	6.67	3.58	1.86	5.38	3.15	1.71	/	/			
-7	8.72	2.29	3.81	8.48	2.49	3.41	8.31	2.61	3.11	7.96	2.81	2.83	7.68	3.05	2.52	7.33	3.26	2.25	7.05	3.53	1.97	5.61	3.10	1.81	/	/			
-5	8.80	2.14	4.12	8.86	2.47	3.60	8.80	2.64	3.33	8.46	2.94	2.88	8.18	3.09	2.65	8.04	3.27	2.46	7.53	3.32	2.27	6.13	3.10	1.98	/	/			
0	9.03	1.83	4.94	9.36	2.31	4.05	9.56	2.55	3.76	9.25	2.93	3.16	8.89	3.10	2.87	8.82	3.27	2.70	8.18	3.31	2.47	6.99	3.30	2.12	/	/			
5	9.94	1.77	5.75	9.97	2.07	4.81	10.1	2.25	4.51	10.1	2.64	3.83	9.79	2.88	3.40	9.45	3.14	3.01	9.08	3.27	2.78	7.85	3.20	2.45	4.52	3.30	1.37		
7	10.5	1.73	5.94	10.3	1.97	5.21	10.3	2.09	4.93	10.5	2.50	4.18	10.3	2.73	3.77	9.83	3.05	3.22	9.72	3.20	3.04	8.23	2.96	2.78	4.85	3.11	1.56		
10	11.2	1.59	7.04	10.4	1.85	5.64	10.0	1.96	5.13	9.94	2.38	4.17	9.87	2.69	3.67	9.59	2.91	3.30	9.57	3.11	3.08	8.27	3.04	2.72	6.44	3.05	2.11		
15	11.4	1.41	8.10	10.6	1.64	6.49	10.2	1.73	5.90	10.1	2.11	4.80	10.1	2.39	4.22	9.78	2.58	3.80	9.76	2.76	3.54	8.43	2.70	3.13	6.56	2.71	2.43		
20	10.8	1.19	9.05	10.8	1.35	7.96	10.7	1.59	6.72	10.7	1.89	5.66	10.3	2.12	4.86	10.0	2.38	4.21	9.85	2.54	3.88	8.90	2.56	3.48	/	/	/		
25	9.94	1.04	9.59	9.90	1.17	8.44	9.82	1.38	7.12	9.82	1.64	6.00	9.46	1.84	5.15	9.22	2.07	4.46	9.06	2.20	4.11	8.18	2.22	3.69	/	/	/		
30	9.77	0.96	10.2	9.07	1.10	8.79	8.90	1.12	7.95	8.85	1.32	6.72	9.92	1.61	6.15	9.31	1.88	4.96	9.04	1.88	4.80	7.49	1.96	3.83	/	/	/		
35	10.2	0.95	10.7	9.44	1.03	9.15	9.25	1.11	8.30	9.21	1.32	6.97	10.3	1.61	6.40	9.69	1.87	5.17	9.42	1.90	4.96	/	/	/	/	/	/		
40	10.7	0.93	11.5	9.91	1.01	9.81	9.71	1.15	8.47	9.67	1.32	7.34	10.8	1.60	6.79	10.2	1.84	5.53	/	/	/	/	/	/	/	/	/		
43	11.0	0.91	12.0	10.2	0.96	10.6	10.0	1.08	9.25	9.96	1.23	8.07	11.2	1.47	7.58	10.5	1.68	6.25	/	/	/	/	/	/	/	/	/		
Normal																													
DB	LWT																												
	25			30			35			40			45			50			55			60			65				
	HC	PI	COP	HC	PI	COP	HC	PI	COP	HC	PI	COP	HC	PI	COP	HC	PI	COP	HC	PI	COP	HC	PI	COP	HC	PI	COP	HC	PI
-25	4.33	1.87	2.32	3.87	1.89	2.05	3.45	2.05	1.68	3.26	2.07	1.57	2.78	2.14	1.30	/	/	/	/	/	/	/	/	/	/	/	/		
-20	5.47	1.87	2.93	4.87	1.98	2.46	4.50	2.05	2.20	4.17	2.29	1.82	3.61	2.20	1.64	3.11	2.17	1.44	2.65	2.09	1.27	/	/	/	/	/	/		
-15	6.57	1.86	3.53	6.10	2.03	3.01	5.73	2.24	2.56	5.31	2.27	2.34	4.94	2.41	2.05	4.38	2.46	1.78	4.79	2.76	1.74	3.91	2.75	1.42	/	/	/		
-10	7.49	1.97	3.81	7.25	2.15	3.37	6.95	2.26	3.08	6.84	2.50	2.74	6.69	2.78	2.41	6.41	2.96	2.16	6.08	3.23	1.88	4.96	2.91	1.70	/	/	/		
-7	8.28	2.11	3.92	8.18	2.33	3.51	8.25	2.62	3.15	7.43	2.54	2.93	7.35	2.88	2.55	7.00	3.04	2.30	6.85	3.43	2.00	5.14	0.00	1.84	/	/	/		
-5	7.93	1.82	4.35	7.90	2.12	3.73	7.66	2.21	3.47	7.45	2.45	3.04	7.13	2.60	2.75	6.88	2.72	2.53	6.49	2.78	2.34	5.46	2.71	2.02	/	/	/		
0	8.33	1.64	5.06	8.52	2.05	4.15	8.63	2.24	3.86	8.53	2.66	3.20	7.87	2.65	2.97	8.03	2.92	2.75	7.30	2.87	2.54	6.16	2.91	2.11	/	/	/		
5	9.09	1.53	5.95	9.00	1.81	4.99	9.07	1.94	4.68	9.23	2.35	3.92	8.58	2.41	3.55	8.53	2.76	3.09	8.02	2.82	2.84	6.86	2.77	2.48	3.86	2.75	1.40		
7	10.2	1.69	6.05	9.98	1.85	5.40	10.0	2.00	5.00	10.1	2.37	4.29	10.0	2.63	3.80	9.58	2.92	3.28	9.50	3.06	3.10	7.70	2.72	2.83	4.29	2.66	1.61		
10	10.1	1.34	7.50	9.12	1.54	5.91	8.85	1.68	5.28	8.88	2.04	4.35	8.94	2.40	3.72	8.86	2.62	3.39	8.34	2.65	3.14	7.60	2.74	2.77	5.66	2.62	2.16		
15	10.3	1.18	8.83	9.40	1.35	6.96	9.13	1.47	6.22	9.16	1.79	5.12	9.22	2.10	4.38	9.14	2.29	3.99	8.60	2.34	3.67	7.84	2.42	3.23	5.97	2.39	2.50		
20	9.88	0.99	9.94	9.58	1.11	8.60	9.58	1.34	7.14	9.70	1.60	6.08	9.46	1.86	5.08	9.41	2.11	4.46	8.73	2.16	4.05	8.31	2.38	3.49	/	/	/		
25	8.86	0.83	10.6	8.98	0.98	9.18	8.99	1.18	7.63	9.10	1.40	6.49	8.87	1.63	5.43	8.82	1.85	4.76	8.19	1.89	4.32	7.79	2.09	3.73	/	/	/		
30	8.76	0.77	11.3	8.28	0.86	9.63	8.19	0.96	8.57	8.24	1.13	7.32	9.35	1.43	6.53	8.96	1.68	5.33	8.21	1.61	5.08	7.17	1.84	3.90	/	/	/		
35	9.19	0.76	12.0	8.69	0.86	10.1	8.59	0.95	9.01	8.65	1.13	7.65	9.81	1.43	6.84	9.39	1.68	5.59	8.63	1.63	5.29	/	/	/	/	/	/		
40	9.79	0.75	13.0	8.97	0.82	10.9	8.75	0.95	9.26	8.82	1.09	8.11	10.0	1.37	7.31	9.59	1.59	6.02	/	/	/	/	/	/	/	/	/		
43	10.2	0.74	13.7	9.32	0.79	11.9	9.10	0.89	10.2	9.16	1.02	8.98	10.4	1.27	8.21	9.96	1.45	6.85	/	/	/	/	/	/	/	/	/		
Minimum																													
DB	LWT																												
	25			30			35			40			45			50			55			60			65				
	HC	PI	COP	HC	PI	COP	HC	PI	COP	HC	PI	COP	HC	PI	COP	HC	PI	COP	HC	PI	COP	HC	PI	COP	HC	PI	COP	HC	PI
-25	2.81	1.19	2.35	2.61	1.26	2.08	2.61	1.53	1.71	2.50	1.56	1.60	1.87	1.43	1.31	/	/	/	/	/	/	/	/	/	/	/	/		
-20	3.35	1.12	2.99	2.89	1.15	2.50	2.89	1.29	2.24	2.91	1.57	1.85	2.41	1.46	1.66	2.31	1.59	1.45	2.01	1.57	1.28	/	/	/	/	/	/		
-15	3.39	0.94	3.61	3.29	1.07	3.08	3.06	1.17	2.62	3.28	1.37	2.40	3.56	1.71	2.08	3.39	1.88	1.81	3.53	2.00	1.76	2.98	2.07	1.44	/	/	/		
-10	3.32	0.85	3.91	3.18	0.92	3.47	3.11	0.98	3.17	3.97	1.41	2.82	4.47	1.82	2.46	4.78	2.17	2.20	4.62	2.40	1.92	3.87	2.22	1.74	/	/	/		
-7	2.09	0.51	4.14	1.95	0.54	3.64	2.05	0.61	3.37	3.52	1.14	3.08	3.77	1.41	2.67	3.82	1.62	2.36	3.99	1.93	2.07	3.60	1.91	1.88	/	/	/		
-5	2.39	0.53	4.48	2.32	0.60	3.84	2.48	0.70	3.57	3.67	1.17	3.13	3.95	1.41	2.80	4.13	1.60	2.58	4.26	1.79	2.38	3.76	1.83	2.06	/	/	/		
0	2.42	0.46	5.24	2.68	0.62	4.30	2.67	0.67	3.99	3.99	1.20	3.31	3.92	1.29	3.04	4.48	1.59	2.82	4.38	1.68	2.61	4.14	1.91	2.17	/	/	/		
5	3.26	0.53	6.18	3.45	0.67	5.18	3.43	0.71	4.86	4.65	1.14	4.07	4.61	1.26	3.66	5.08	1.60	3.18	5.14	1.76	2.92	4.89	1.92	2.55	2.87	2.02	1.42		
7	3.76	0.58	6.48	3.86	0.68	5.69	3.81	0.71	5.39	4.92	1.09	4.53	5.55	1.36	4.09	6.10	1.76	3.46	6.17	1.90	3.25	5.41	1.85	2.93	3.19	1.96	1.63		
10	3.43	0.44	7.86	3.05	0.49	6.19	3.17	0.57	5.54	4.47	0.98	4.55	5.34	1.38	3.86	5.78	1.64	3.52	6.04	1.85	3.27	5.54	1.92	2.88	4.38	1.98	2.22		
15	4.48	0.48	9.32	4.17	0.57	7.35	4.00	0.61	6.58	4.69	0.87	5.40	5.58	1.21	4.59	6.03	1.44	4.18	7.03	1.83	3.85	6.16	1.88	3.27	4.40	1.71	2.56		
20	4.86	0.46	10.5	5.27	0.58	9.10	5.66	0.75	7.56	6.73	1.05	6.44	6.38	1.19	5.34	6.51	1.39	4.68	6.60	1.55	4.25	5.96	1.62	3.67	/	/	/		
25	5.47	0.49	11.2	5.84	0.60	9.72	6.19	0.77	8.07	7.17	1.04	6.87	6.81	1.19	5.70	6.92	1.38	5.00	6.51	1.43	4.54	5.97</							

Table 2-5.3: Heating capacity for SHPAO16RP24P3CM

Maximum																											
DB	LWT																										
	25			30			35			40			45			50			55			60			65		
	HC	PI	COP	HC	PI	COP	HC	PI	COP	HC	PI	COP	HC	PI	COP	HC	PI	COP	HC	PI	COP	HC	PI	COP	HC	PI	COP
-25	7.69	4.03	1.91	7.99	4.22	1.93	6.61	4.01	1.65	5.89	4.43	1.33	4.96	4.21	1.18	/	/	/	/	/	/	/	/	/	/		
-20	9.57	3.94	2.38	9.71	4.43	2.19	8.16	4.77	1.71	7.48	4.76	1.57	6.55	4.85	1.35	5.85	4.54	1.29	5.37	4.75	1.13	/	/	/	/		
-15	11.8	4.37	2.71	11.3	4.60	2.45	10.7	4.93	2.17	10.1	5.24	1.92	9.03	5.38	1.68	7.53	5.32	1.42	6.82	5.29	1.29	6.42	5.59	1.15	/		
-10	13.4	4.51	2.97	13.0	4.78	2.72	12.7	5.09	2.49	12.4	5.43	2.28	11.1	5.61	1.96	9.49	5.56	1.70	8.92	5.88	1.51	7.04	5.59	1.26	/		
-7	14.3	4.59	3.13	14.1	4.89	2.88	13.9	5.19	2.67	13.8	5.55	2.50	13.1	6.02	2.18	12.9	6.22	2.07	12.6	6.29	2.00	8.25	6.18	1.33	/		
-5	14.6	4.27	3.47	14.3	4.61	3.13	14.0	4.93	2.86	13.8	5.33	2.61	13.4	5.88	2.28	13.0	5.82	2.22	12.6	5.92	2.13	8.62	5.97	1.45	/		
0	15.1	3.49	4.33	14.7	3.91	3.75	14.3	4.27	3.34	13.9	4.80	2.88	14.1	5.33	2.64	13.4	5.14	2.61	12.8	5.42	2.37	9.56	5.54	1.72	/		
5	16.8	3.25	5.19	14.6	3.61	4.06	16.1	4.00	4.04	15.6	4.57	3.43	15.9	4.96	3.20	15.3	5.05	3.02	14.5	5.21	2.77	12.7	5.36	2.37	10.7		
7	17.5	3.16	5.53	15.7	3.12	4.68	16.8	3.79	4.43	16.4	4.25	3.85	16.6	4.71	3.53	16.2	5.05	3.17	16.2	5.53	2.89	14.1	5.34	2.63	11.3		
10	18.0	3.01	6.02	16.4	3.34	4.96	17.6	3.73	4.74	17.1	4.33	3.96	17.3	4.72	3.67	16.7	5.12	3.26	16.1	5.16	3.11	14.3	5.15	2.79	12.2		
15	18.9	2.76	6.84	19.3	3.08	6.26	18.9	3.48	5.43	18.3	4.08	4.48	18.5	4.53	4.09	17.8	4.79	3.72	17.5	5.11	3.42	14.7	4.83	3.06	12.5		
20	16.7	2.08	8.03	16.9	2.38	7.10	16.7	2.69	6.21	17.4	3.40	5.12	16.1	3.77	4.28	14.6	4.06	3.60	15.0	4.32	3.46	13.1	4.39	3.00	/		
25	16.2	1.83	8.86	16.2	2.23	7.16	16.0	2.31	6.94	16.6	2.87	5.81	15.7	3.23	4.87	14.5	3.46	4.20	14.1	3.68	3.82	12.4	4.05	3.07	/		
30	15.6	1.55	10.1	15.5	1.88	8.21	15.4	2.00	7.68	15.9	2.45	6.49	15.3	2.81	5.46	14.4	3.01	4.79	13.2	3.15	4.18	12.7	4.11	3.10	/		
35	16.3	1.50	10.8	16.6	1.84	9.01	16.3	1.94	8.42	16.6	2.42	6.87	15.9	2.79	5.68	15.0	3.00	5.01	13.4	3.07	4.35	/	/	/	/		
40	16.9	1.47	11.5	17.6	1.75	10.1	17.2	1.88	9.15	17.4	2.40	7.24	16.4	2.78	5.91	15.6	2.98	5.22	/	/	/	/	/	/	/		
43	17.2	1.46	11.8	18.0	1.71	10.5	17.6	1.88	9.37	17.7	2.39	7.41	16.7	2.70	6.20	15.9	2.94	5.41	/	/	/	/	/	/	/		
Normal																											
DB	LWT																										
	25			30			35			40			45			50			55			60			65		
	HC	PI	COP	HC	PI	COP	HC	PI	COP	HC	PI	COP	HC	PI	COP	HC	PI	COP	HC	PI	COP	HC	PI	COP	HC	PI	COP
-25	6.57	3.24	2.03	6.79	3.29	2.06	5.57	3.21	1.73	5.04	3.65	1.38	4.30	3.60	1.19	/	/	/	/	/	/	/	/	/	/		
-20	8.42	3.29	2.56	8.50	3.59	2.37	7.07	3.88	1.82	6.59	3.99	1.65	5.74	4.14	1.39	5.15	3.88	1.33	4.89	4.33	1.13	/	/	/	/		
-15	9.89	3.37	2.93	9.35	3.52	2.66	8.80	3.79	2.32	8.41	4.14	2.03	7.38	4.26	1.73	6.18	4.21	1.47	5.71	4.40	1.30	5.43	4.77	1.14	/		
-10	11.1	3.51	3.15	10.7	3.68	2.90	10.3	3.95	2.61	10.3	4.34	2.37	9.25	4.59	2.01	7.98	4.55	1.75	7.51	4.83	1.55	5.99	4.69	1.28	/		
-7	13.9	4.27	3.25	13.5	4.44	3.05	13.3	4.93	2.70	13.1	4.98	2.63	12.9	5.78	2.23	12.4	5.83	2.12	12.5	6.19	2.02	7.69	5.60	1.37	/		
-5	12.1	3.21	3.77	11.7	3.49	3.36	11.2	3.65	3.07	11.2	3.98	2.82	10.7	4.44	2.42	10.2	4.83	2.11	9.98	4.50	2.22	7.08	4.76	1.49	/		
0	12.0	2.54	4.72	11.5	2.86	4.04	10.9	3.05	3.59	10.7	3.43	3.13	10.8	3.83	2.81	10.1	4.00	2.52	9.77	3.91	2.50	7.66	4.30	1.78	/		
5	13.5	2.37	5.71	11.7	2.64	4.41	12.5	2.85	4.38	12.3	3.27	3.76	12.3	3.58	3.44	11.6	3.90	2.97	11.1	3.79	2.93	10.1	4.09	2.47	8.84		
7	17.0	2.87	5.91	15.2	2.98	5.11	16.0	3.56	4.50	15.7	3.99	3.94	16.0	4.44	3.60	16.0	4.92	3.24	16.0	5.52	2.90	13.2	4.86	2.72	10.2		
10	14.2	2.14	6.66	12.8	2.36	5.42	13.4	2.59	5.16	13.2	3.01	4.36	13.2	3.33	3.97	12.5	3.66	3.41	12.1	3.71	3.25	11.2	3.88	2.88	9.92		
15	15.0	1.97	7.63	15.2	2.20	6.89	14.5	2.43	5.97	14.2	2.84	4.98	14.2	3.19	4.46	13.4	3.41	3.92	13.2	3.67	3.61	11.6	3.64	3.19	10.2		
20	13.2	1.46	9.04	13.2	1.67	7.89	12.7	1.84	6.88	13.3	2.32	5.75	12.2	2.59	4.71	10.9	2.83	3.84	11.2	3.04	3.68	10.2	3.24	3.15	/		
25	12.8	1.29	9.97	12.7	1.57	8.06	12.2	1.59	7.71	12.9	1.78	7.22	12.0	2.24	5.36	10.8	2.43	4.47	10.6	2.60	4.07	9.73	3.01	3.23	/		
30	12.5	1.11	11.3	12.2	1.35	9.06	11.8	1.40	8.47	12.4	1.55	7.98	11.8	2.06	5.74	10.9	2.15	5.07	10.0	2.29	4.37	10.1	3.12	3.23	/		
35	13.3	1.10	12.0	13.3	1.35	9.90	12.8	1.41	9.06	13.2	1.79	7.40	12.5	2.07	6.02	11.5	2.16	5.34	10.4	2.27	4.57	/	/	/	/		
40	14.1	1.10	12.8	14.6	1.31	11.1	13.9	1.40	9.91	14.1	1.80	7.86	13.2	2.10	6.30	12.3	2.19	5.61	/	/	/	/	/	/	/		
43	14.7	1.10	13.3	15.1	1.29	11.7	14.4	1.41	10.2	14.7	1.81	8.10	13.7	2.06	6.66	12.8	2.19	5.85	/	/	/	/	/	/	/		
Minimum																											
DB	LWT																										
	25			30			35			40			45			50			55			60			65		
	HC	PI	COP	HC	PI	COP	HC	PI	COP	HC	PI	COP	HC	PI	COP	HC	PI	COP	HC	PI	COP	HC	PI	COP	HC	PI	COP
-25	4.38	2.11	2.08	4.74	2.25	2.11	4.30	2.44	1.76	4.01	2.86	1.40	3.33	2.77	1.20	/	/	/	/	/	/	/	/	/	/		
-20	5.31	2.04	2.60	5.58	2.33	2.40	4.61	2.50	1.85	4.36	2.60	1.68	4.25	3.10	1.37	4.10	3.11	1.32	3.81	3.38	1.13	/	/	/	/		
-15	6.45	2.15	3.00	6.37	2.34	2.72	5.94	2.50	2.38	5.77	2.77	2.08	5.78	3.33	1.73	5.20	3.54	1.47	4.78	3.66	1.30	4.62	4.04	1.15	/		
-10	5.70	1.74	3.27	5.80	1.93	3.01	5.52	2.06	2.68	5.63	2.31	2.43	5.75	2.80	2.05	5.41	3.03	1.79	5.53	3.49	1.58	4.71	3.62	1.30	/		
-7	5.38	1.53	3.52	4.96	1.55	3.21	4.99	1.68	2.97	5.58	1.99	2.80	6.83	2.86	2.38	6.94	3.17	2.19	7.11	3.27	2.17	5.36	3.80	1.41	/		
-5	5.60	1.43	3.93	5.16	1.47	3.50	5.17	1.62	3.20	5.72	1.94	2.94	7.09	2.84	2.50	7.12	3.29	2.17	7.31	3.20	2.28	5.69	3.72	1.53	/		
0	6.04	1.22	4.94	5.72	1.35	4.23	5.49	1.46	3.76	5.93	1.81	3.28	7.66	2.62	2.92	7.58	2.91	2.60	7.52	2.91	2.59	6.32	3.43	1.84	/		
5	6.80	1.13	5.99	5.78	1.25	4.64	6.27	1.36	4.60	6.77	1.71	3.95	8.74	2.43	3.59	8.70	2.82	3.09	9.11	3.00	3.04	8.65	3.36	2.57	7.55		
7	6.96	1.08	6.43	5.67	1.05	5.38	6.43	1.27	5.08	6.97	1.56	4.46	9.02	2.26	3.99	9.01	2.58	3.49	9.96	3.13	3.19	9.46	3.29	2.87	7.87		
10	7.35	1.05	7.01	6.51	1.14	5.70	6.91	1.27	5.44	7.44	1.62	4.59	9.58	2.31	4.15	9.56	2.66	3.59	10.2	2.99	3.40	9.78	3.24	3.02	8.66		
15	7.40	0.93	7.99	7.57	1.05	7.22	7.39	1.18	6.26	8.45	1.62	5.22	10.3	2.21	4.64	11.0	2.67	4.12	11.4	3.02	3.75	10.5	3.16	3.32	9.17		
20	6.67	0.70	9.46	6.76	0.82	8.27	6.65	0.92	7.21	8.17	1.36	6.02	9.04	1.85	4.89	9.12	2.26	4.03	9.82	2.57	3.83	9.42	2.87	3.28	/		
25	6.62	0.63	10.4	6.64	0.79	8.45	6.54	0.81	8.07	7.99	1.17	6.82	8.98	1.61	5.57	9.20	1.96	4.69	9.38	2.22	4.23	9.04	2.69	3.36	/		
30	7.29	0.62	11.8	7.58	0.80	9.48	8.38	0.96	8.70	8.91	1.21	7.36	8.88	1.47	6.03	9.25	1.74	5.33	8.95	1.95	4.59	9.05	2.66	3.40	/		
35	7.75	0.61	12.7	8.28	0.79	10.5	9.05	0.94	9.60	9.48	1.21	7.85	9.34	1.48	6.33	9.77	1.74	5.61	9.23	1.92	4.81	/	/	/	/		
40	8.22	0.61	13.6	9.00	0.76	11.8	9.75	0.																			

5.2 Cooling Capacity Tables (Test standard: EN14511)

Table 2-5.4: SHPA06RP24CM cooling capacity

Maximum															
DB	LWT														
	5			10			15			20			25		
	CC	PI	EER	CC	PI	EER	CC	PI	EER	CC	PI	EER	CC	PI	EER
-5	/	/	/	/	/	/	5.27	0.59	8.93	6.38	0.55	11.53	6.77	0.64	10.62
0	/	/	/	/	/	/	5.05	0.69	7.28	6.16	0.66	9.39	6.55	0.74	8.85
5	/	/	/	/	/	/	4.55	0.79	5.74	5.66	0.76	7.48	6.05	0.84	7.20
10	/	/	/	/	/	/	6.32	1.13	5.61	6.90	1.01	6.83	7.45	0.95	7.88
15	/	/	/	5.89	1.10	5.33	8.09	1.46	5.55	8.14	1.26	6.44	8.85	1.05	8.43
20	5.41	1.38	3.93	6.63	1.43	4.62	8.16	1.49	5.47	8.33	1.30	6.42	8.98	1.10	8.15
25	7.16	1.80	3.98	7.37	1.77	4.17	8.23	1.53	5.39	8.52	1.33	6.40	9.12	1.15	7.90
30	6.50	1.85	3.51	7.29	1.90	3.84	7.77	1.65	4.72	8.19	1.46	5.63	8.77	1.30	6.75
35	5.84	1.90	3.07	7.22	2.03	3.55	7.31	1.76	4.15	7.87	1.58	4.98	8.43	1.44	5.84
40	3.80	1.51	2.52	5.08	1.81	2.81	5.91	1.73	3.41	6.63	1.68	3.95	7.88	1.64	4.80
43	2.58	1.15	2.24	3.80	1.52	2.51	5.08	1.56	3.26	5.88	1.57	3.74	7.55	1.59	4.73
Normal															
DB	LWT														
	5			10			15			20			25		
	CC	PI	EER	CC	PI	EER	CC	PI	EER	CC	PI	EER	CC	PI	EER
-5	/	/	/	/	/	/	4.24	0.42	10.18	5.19	0.38	13.72	5.50	0.42	12.96
0	/	/	/	/	/	/	4.07	0.48	8.48	5.02	0.44	11.39	5.33	0.48	11.01
5	/	/	/	/	/	/	3.64	0.58	6.31	4.54	0.53	8.61	4.91	0.58	8.49
10	/	/	/	/	/	/	5.08	0.82	6.18	5.55	0.71	7.86	6.06	0.65	9.31
15	/	/	/	4.42	0.78	5.65	6.79	1.15	5.89	7.00	0.99	7.06	7.44	0.80	9.29
20	4.22	1.02	4.14	5.36	1.08	4.96	6.80	1.16	5.88	7.17	1.03	6.94	7.82	0.87	8.98
25	5.67	1.35	4.21	6.05	1.35	4.49	6.96	1.21	5.74	7.44	1.07	6.98	8.05	0.91	8.85
30	5.23	1.40	3.74	6.08	1.48	4.10	6.67	1.32	5.06	7.25	1.20	6.05	7.85	1.06	7.44
35	4.54	1.41	3.22	5.93	1.55	3.83	6.02	1.35	4.47	6.87	1.28	5.36	7.69	1.20	6.39
40	3.10	1.15	2.70	4.30	1.42	3.03	5.15	1.40	3.68	5.95	1.37	4.34	7.15	1.32	5.41
43	2.12	0.91	2.33	2.99	1.15	2.59	4.04	1.18	3.43	5.04	1.25	4.04	5.97	1.15	5.18
Minimum															
DB	LWT														
	5			10			15			20			25		
	CC	PI	EER	CC	PI	EER	CC	PI	EER	CC	PI	EER	CC	PI	EER
-5	/	/	/	/	/	/	2.75	0.25	10.92	3.35	0.23	14.26	3.57	0.27	13.17
0	/	/	/	/	/	/	2.64	0.29	9.00	3.25	0.28	11.72	3.47	0.31	11.08
5	/	/	/	/	/	/	1.96	0.28	6.95	2.46	0.27	9.16	2.64	0.30	8.84
10	/	/	/	/	/	/	2.81	0.41	6.87	3.10	0.37	8.44	3.36	0.34	9.78
15	/	/	/	2.71	0.45	5.99	3.64	0.58	6.29	3.50	0.45	7.80	4.25	0.41	10.32
20	2.13	0.50	4.30	2.35	0.45	5.17	3.38	0.54	6.23	3.95	0.54	7.32	4.44	0.47	9.50
25	2.72	0.63	4.31	2.50	0.53	4.72	3.29	0.54	6.04	3.92	0.53	7.33	4.38	0.47	9.28
30	2.48	0.65	3.81	2.49	0.58	4.30	3.12	0.59	5.30	3.79	0.59	6.38	4.23	0.55	7.72
35	2.07	0.62	3.31	2.75	0.69	4.00	3.01	0.63	4.79	3.66	0.63	5.81	4.23	0.62	6.84
40	1.40	0.52	2.69	2.01	0.64	3.12	2.52	0.66	3.82	3.18	0.71	4.50	4.07	0.74	5.51
43	0.73	0.31	2.38	1.43	0.53	2.68	2.11	0.59	3.57	2.57	0.62	4.17	3.80	0.71	5.38

Abbreviations:

LWT: Leaving water temperature (°C)

DB: Dry-bulb temperature for Outdoor air temperature (°C)

CC: Total cooling capacity (kW)

PI: Power input (kW)

Table 2-5.5: SHPAO10RP24CM cooling capacity

Maximum															
DB	LWT														
	5			10			15			20			25		
	CC	PI	EER	CC	PI	EER	CC	PI	EER	CC	PI	EER	CC	PI	EER
-5	/	/	/	/	/	/	6.83	0.69	9.92	8.79	0.82	10.66	9.35	0.77	12.13
0	/	/	/	/	/	/	6.61	0.77	8.56	7.76	0.81	9.61	8.30	0.76	10.88
5	/	/	/	/	/	/	6.38	0.89	7.19	6.74	0.79	8.56	7.25	0.75	9.63
10	/	/	/	/	/	/	6.55	0.75	8.73	8.17	0.80	10.18	8.80	0.86	10.22
15	/	/	/	6.30	1.07	5.89	7.61	1.03	7.35	9.48	1.13	8.38	10.64	1.20	8.84
20	6.20	1.28	4.86	7.19	1.39	5.17	8.67	1.45	5.97	10.79	1.64	6.57	12.49	1.68	7.45
25	7.13	1.68	4.24	8.26	1.81	4.56	9.87	1.88	5.24	12.00	2.07	5.79	13.93	2.17	6.42
30	8.06	2.17	3.71	9.34	2.31	4.05	11.08	2.40	4.62	13.21	2.57	5.14	15.37	2.79	5.51
35	8.13	2.48	3.12	9.48	2.43	3.72	11.03	2.62	4.21	12.70	2.68	4.73	14.51	2.87	5.06
40	6.61	2.52	2.62	7.42	2.37	3.14	8.88	2.53	3.51	10.23	2.51	4.07	12.27	2.83	4.34
43	5.09	2.28	2.23	5.64	2.19	2.58	6.73	2.13	3.16	8.15	2.17	3.75	10.04	2.49	4.03
Normal															
DB	LWT														
	5			10			15			20			25		
	CC	PI	EER	CC	PI	EER	CC	PI	EER	CC	PI	EER	CC	PI	EER
-5	/	/	/	/	/	/	5.50	0.49	11.21	7.15	0.58	12.31	7.59	0.55	13.82
0	/	/	/	/	/	/	5.33	0.54	9.79	6.33	0.57	11.14	6.75	0.53	12.66
5	/	/	/	/	/	/	5.11	0.65	7.84	5.41	0.57	9.54	5.88	0.56	10.60
10	/	/	/	/	/	/	5.26	0.55	9.53	6.58	0.58	11.37	7.16	0.64	11.26
15	/	/	/	4.73	0.76	6.24	6.39	0.82	7.80	8.15	0.89	9.18	8.94	0.92	9.74
20	4.83	0.95	5.11	5.82	1.05	5.55	7.23	1.13	6.42	9.29	1.31	7.10	10.87	1.32	8.21
25	5.65	1.26	4.49	6.78	1.38	4.91	8.35	1.50	5.58	10.47	1.66	6.32	12.30	1.71	7.18
30	6.48	1.64	3.95	7.78	1.80	4.32	9.51	1.92	4.95	11.69	2.12	5.51	13.76	2.26	6.08
35	6.31	1.93	3.28	7.78	1.94	4.01	9.09	2.01	4.53	11.08	2.18	5.09	13.23	2.39	5.54
40	5.40	1.92	2.81	6.27	1.86	3.38	7.73	2.04	3.79	9.18	2.06	4.47	11.14	2.28	4.89
43	4.18	1.80	2.32	4.44	1.66	2.67	5.36	1.61	3.32	6.98	1.72	4.06	7.94	1.80	4.41
Minimum															
DB	LWT														
	5			10			15			20			25		
	CC	PI	EER	CC	PI	EER	CC	PI	EER	CC	PI	EER	CC	PI	EER
-5	/	/	/	/	/	/	3.56	0.30	11.68	4.61	0.36	12.69	4.93	0.34	14.49
0	/	/	/	/	/	/	3.46	0.34	10.23	4.09	0.35	11.61	4.39	0.33	13.14
5	/	/	/	/	/	/	2.75	0.33	8.42	2.93	0.29	10.13	3.17	0.28	11.40
10	/	/	/	/	/	/	2.92	0.28	10.33	3.67	0.30	12.18	3.97	0.33	12.22
15	/	/	/	2.90	0.44	6.62	3.42	0.41	8.33	4.08	0.40	10.14	5.11	0.47	10.81
20	2.44	0.46	5.31	2.55	0.44	5.79	3.59	0.53	6.81	5.11	0.68	7.49	6.17	0.71	8.68
25	2.71	0.59	4.60	2.81	0.55	5.15	3.95	0.67	5.88	5.52	0.83	6.64	6.69	0.89	7.54
30	3.08	0.76	4.03	3.19	0.70	4.53	4.45	0.86	5.19	6.10	1.05	5.82	7.41	1.18	6.30
35	2.88	0.85	3.37	3.61	0.86	4.19	4.55	0.94	4.86	5.90	1.07	5.52	7.28	1.23	5.93
40	2.44	0.87	2.80	2.94	0.84	3.48	3.79	0.97	3.93	4.91	1.06	4.64	6.34	1.28	4.97
43	1.43	0.60	2.37	2.12	0.77	2.76	2.80	0.81	3.46	3.55	0.85	4.18	5.06	1.11	4.58

Abbreviations:

LWT: Leaving water temperature (°C)

DB: Dry-bulb temperature for Outdoor air temperature (°C)

CC: Total cooling capacity (kW)

PI: Power input (kW)

Table 2-5.6: SHPAO16RP24P3CM cooling capacity

Maximum															
DB	LWT														
	5			10			15			20			25		
	CC	PI	EER	CC	PI	EER	CC	PI	EER	CC	PI	EER	CC	PI	EER
-5	/	/	/	/	/	/	10.0	1.32	7.57	10.9	1.47	7.44	12.0	1.42	8.43
0	/	/	/	/	/	/	9.80	1.67	5.87	11.4	1.58	7.24	12.5	1.59	7.84
5	/	/	/	/	/	/	9.57	1.76	5.44	12.0	1.61	7.43	13.0	1.68	7.73
10	/	/	/	/	/	/	11.3	2.18	5.21	13.1	1.92	6.85	14.2	1.94	7.32
15	/	/	/	11.4	2.43	4.67	13.5	2.44	5.53	16.1	2.37	6.77	17.0	2.30	7.37
20	8.99	2.43	3.70	14.0	3.55	3.96	15.8	3.56	4.42	16.9	3.36	5.03	17.5	3.04	5.76
25	11.7	3.59	3.25	15.9	4.32	3.69	17.4	4.47	3.90	17.9	4.31	4.14	17.9	3.70	4.84
30	11.5	4.46	2.59	15.5	5.11	3.04	17.2	5.05	3.41	17.1	4.66	3.68	16.9	4.02	4.21
35	11.4	5.42	2.11	15.1	6.00	2.52	16.5	5.60	2.94	16.3	4.96	3.27	16.2	4.47	3.62
40	8.92	5.11	1.75	10.9	4.89	2.22	11.7	4.42	2.65	13.4	4.69	2.86	14.6	4.36	3.34
43	5.98	4.50	1.33	7.33	4.12	1.78	9.01	3.91	2.31	10.5	4.13	2.54	12.0	3.85	3.11
Normal															
DB	LWT														
	5			10			15			20			25		
	CC	PI	EER	CC	PI	EER	CC	PI	EER	CC	PI	EER	CC	PI	EER
-5	/	/	/	/	/	/	8.07	0.94	8.56	8.88	1.03	8.60	9.72	1.01	9.61
0	/	/	/	/	/	/	7.90	1.18	6.71	9.33	1.11	8.39	10.2	1.11	9.13
5	/	/	/	/	/	/	7.67	1.29	5.93	9.61	1.16	8.28	10.6	1.24	8.50
10	/	/	/	/	/	/	9.12	1.60	5.69	10.6	1.38	7.65	11.5	1.43	8.07
15	/	/	/	8.52	1.70	5.02	11.4	1.89	6.01	13.8	1.82	7.59	14.2	1.71	8.31
20	7.01	1.80	3.88	11.4	2.63	4.31	13.1	2.70	4.87	14.5	2.62	5.56	15.3	2.35	6.49
25	9.24	2.69	3.43	13.1	3.25	4.02	14.8	3.47	4.25	15.6	3.37	4.62	15.8	2.85	5.55
30	9.28	3.37	2.75	12.9	3.93	3.29	14.8	3.95	3.74	15.2	3.75	4.04	15.1	3.19	4.75
35	8.87	4.01	2.21	12.4	4.51	2.75	13.6	4.19	3.24	14.2	3.94	3.60	14.7	3.64	4.05
40	7.28	3.89	1.87	9.18	3.78	2.43	10.2	3.49	2.93	12.0	3.75	3.21	13.2	3.43	3.84
43	4.91	3.55	1.38	5.76	3.08	1.87	7.17	2.89	2.48	8.98	3.20	2.81	9.46	2.72	3.48
Minimum															
DB	LWT														
	5			10			15			20			25		
	CC	PI	EER	CC	PI	EER	CC	PI	EER	CC	PI	EER	CC	PI	EER
-5	/	/	/	/	/	/	5.22	0.59	8.92	5.73	0.65	8.86	6.30	0.63	10.08
0	/	/	/	/	/	/	5.13	0.73	7.01	6.04	0.69	8.75	6.61	0.70	9.47
5	/	/	/	/	/	/	4.12	0.65	6.37	5.21	0.59	8.80	5.68	0.62	9.15
10	/	/	/	/	/	/	5.06	0.82	6.16	5.91	0.72	8.20	6.40	0.73	8.75
15	/	/	/	5.23	0.98	5.32	6.08	0.95	6.41	6.91	0.83	8.37	8.14	0.88	9.21
20	3.54	0.88	4.04	4.97	1.11	4.49	6.53	1.27	5.15	8.01	1.37	5.86	8.65	1.26	6.86
25	4.43	1.26	3.52	5.42	1.28	4.22	6.98	1.56	4.47	8.21	1.69	4.85	8.60	1.48	5.81
30	4.41	1.57	2.81	5.31	1.54	3.44	6.92	1.77	3.91	7.92	1.86	4.26	8.15	1.66	4.92
35	4.04	1.78	2.27	5.75	2.00	2.87	6.79	1.96	3.47	7.56	1.94	3.90	8.12	1.87	4.33
40	3.29	1.76	1.86	4.30	1.72	2.50	5.01	1.65	3.03	6.43	1.93	3.33	7.52	1.92	3.91
43	1.68	1.19	1.41	2.76	1.43	1.93	3.75	1.45	2.58	4.57	1.58	2.89	6.03	1.67	3.61

Abbreviations:

LWT: Leaving water temperature (°C)

DB: Dry-bulb temperature for Outdoor air temperature (°C)

CC: Total cooling capacity (kW)

PI: Power input (kW)

6 Operating Limits

Figure 2-6.1: Heating operating limits¹

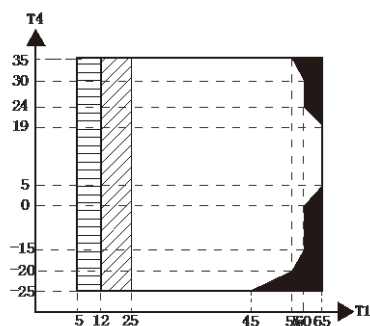

Figure 2-6.2: Cooling operating limits¹

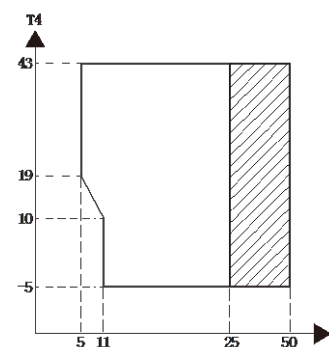
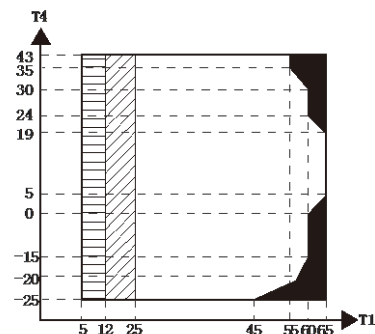

Figure 2-6.3: Domestic hot water operating limits¹



Abbreviations:

T4: Outdoor temperature (°C)

T1: Leaving water temperature (°C)

Notes:

1. If IBH/AHS setting is valid, only IBH/AHS turns on; If IBH/AHS setting is invalid, only heat pump turns on
2. Water flow temperature drop or rise interval
3. IBH/AHS only

7 Hydronic Performance

Figure 2-7.1: SHPAI60(100)RP24CM(-EH) hydronic performance

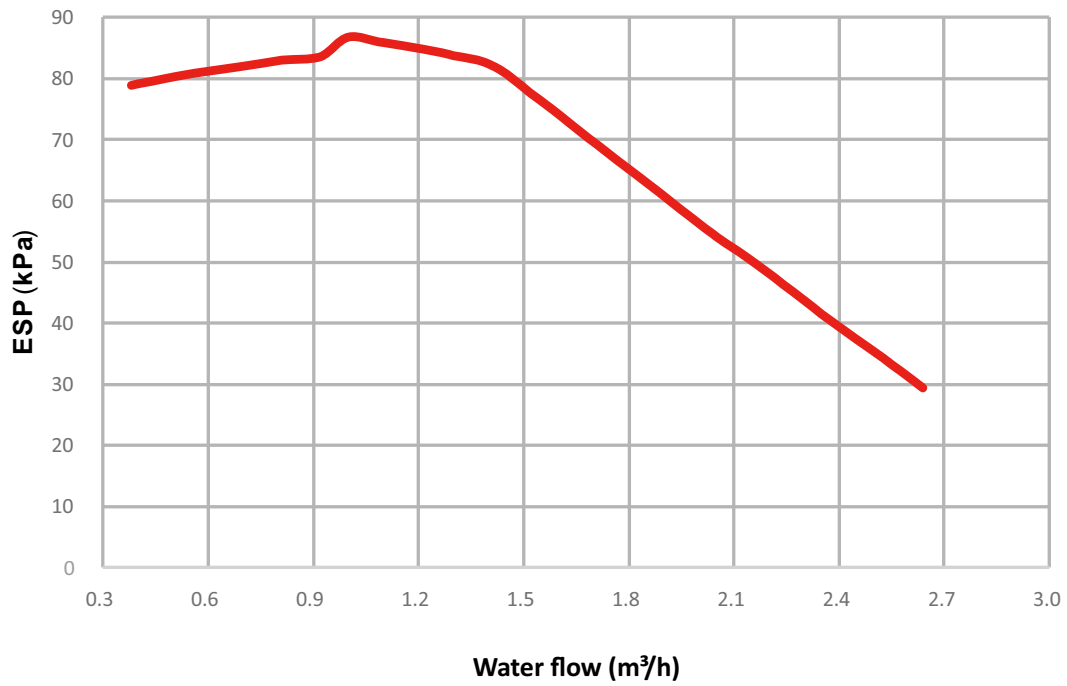
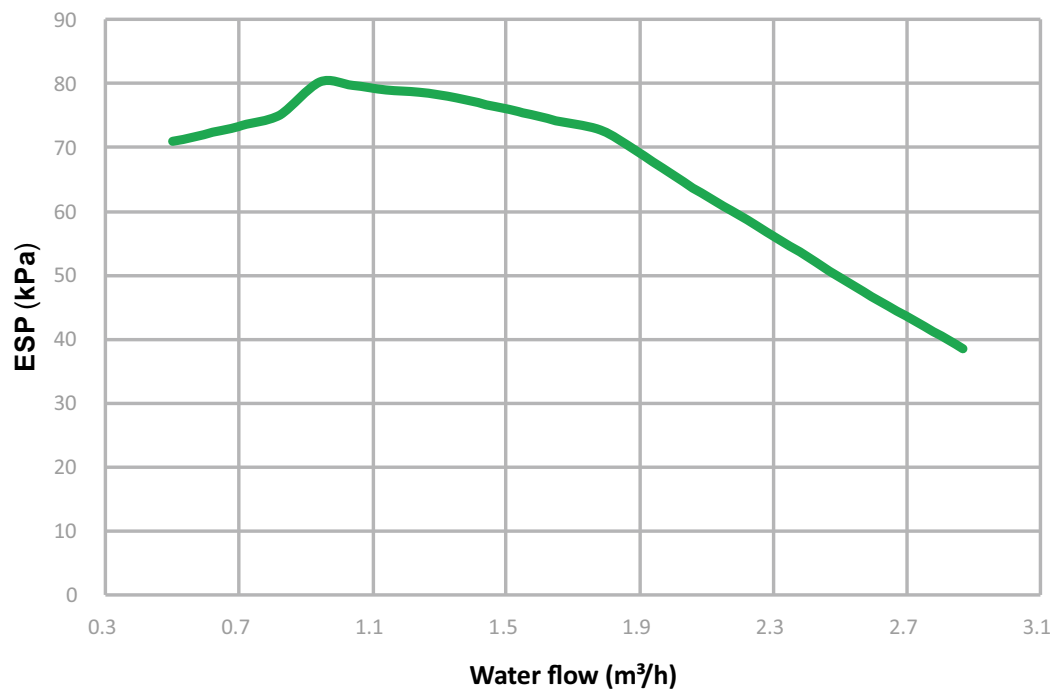

Figure 2-7.2: SHPAI160RP24CM(-EH) hydronic performance



8 Sound Levels

8.1 Overall

Table 2-8.1: Sound pressure levels¹

Model name	dB
SHPAO6RP24CM	45
SHPAO10RP24CM	49
SHPAO16RP24P3CM	55

Notes:

1. Sound pressure is measured at a position 1m in front of the unit and $(1+H)/2$ m (where H is the height of the unit) above the floor in a semi-anechoic chamber. During in-situ operation, sound pressure levels may be higher as a result of ambient noise. Sound pressure level is the maximum value tested under the two conditions of Notes 2 and Notes 3. For 16 kW model, the value is calculated and is for reference only.

Figure 2-8.1: Sound pressure level measurement (unit: mm)

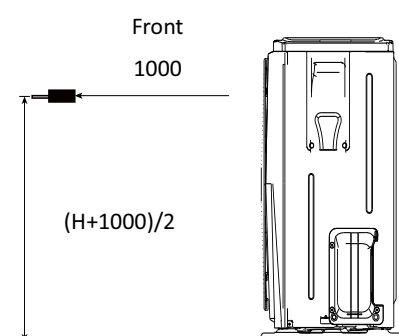

2. Outdoor air temperature 7°C DB, 85% R.H.; EWT 30°C, LWT 35°C.
3. Outdoor air temperature 35°C DB; EWT 23°C, LWT 18°C.

8.2 Octave Band Levels

Figure 2-8.2: SHPAO6RP24CM octave band levels

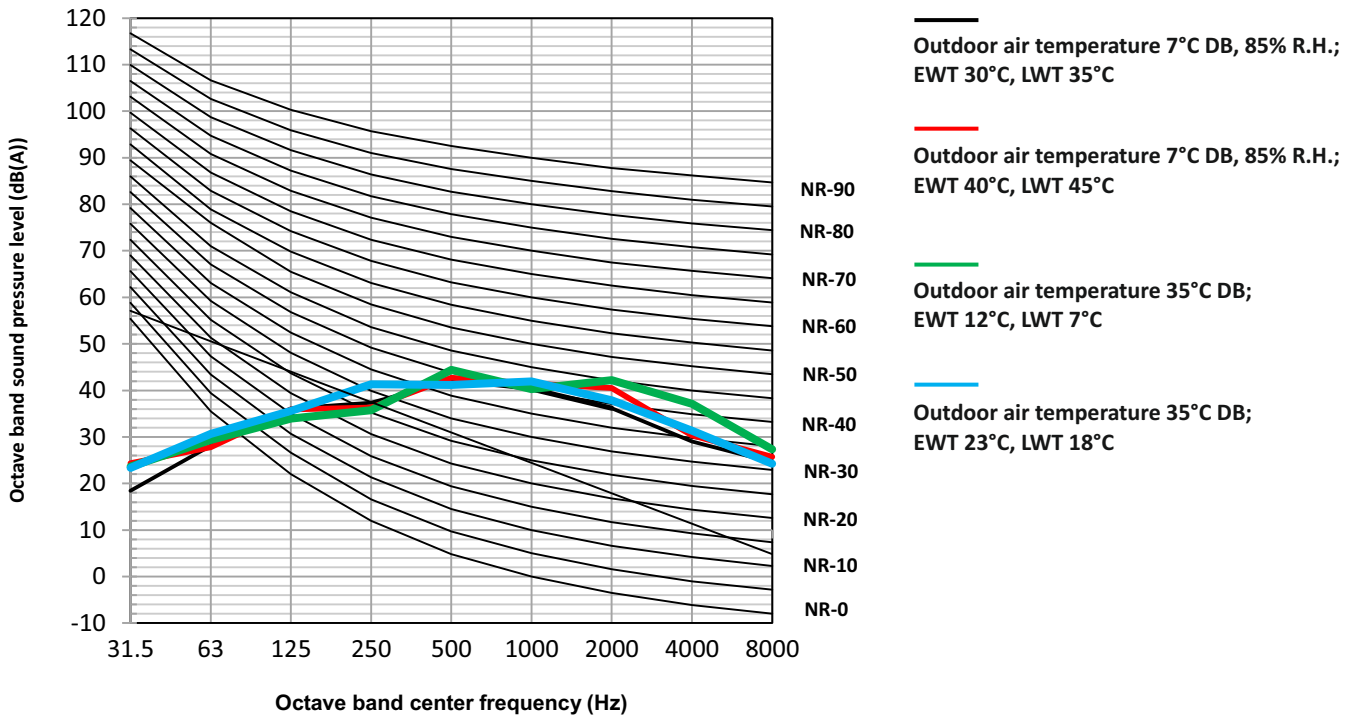
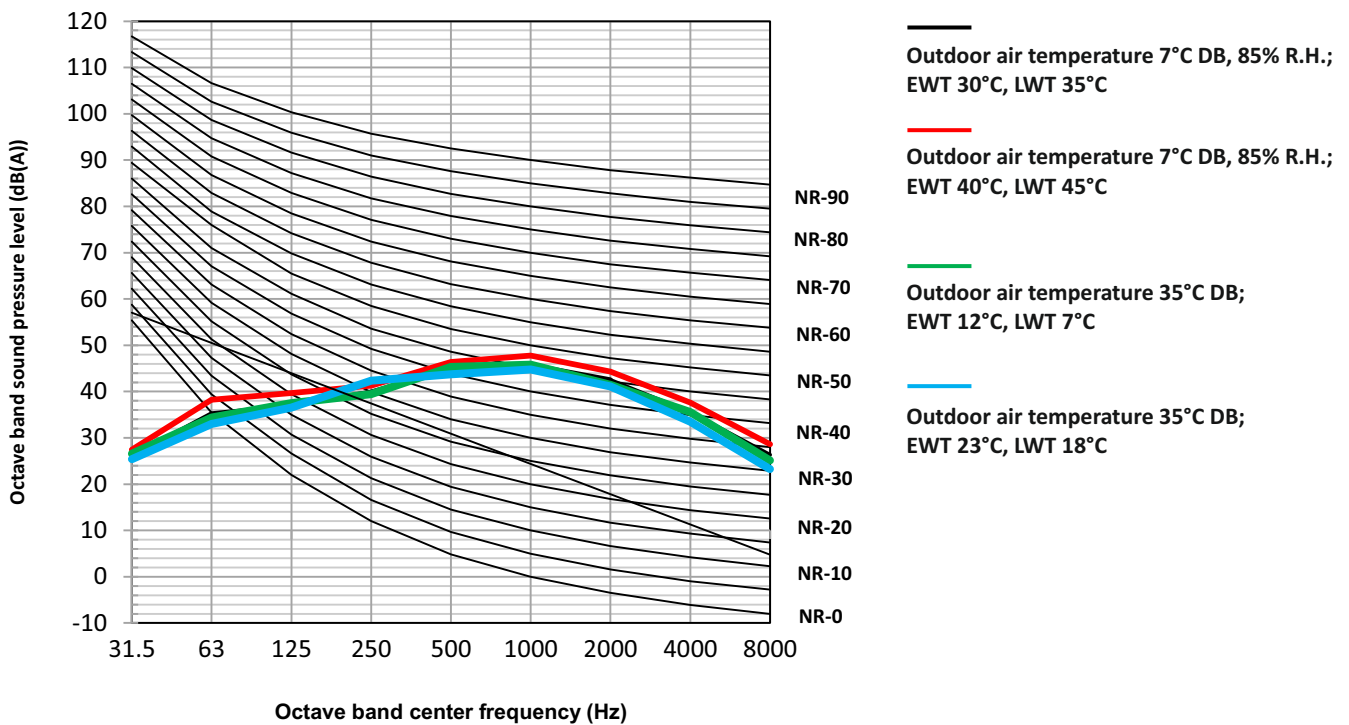





Figure 2-8.3: SHPAO10RP24CM octave band levels



9 Accessories









9.1 Outdoor Unit

Table 2-9.1: Outdoor unit accessories

Name	Shape	Quantity
Service manual		1
Technical manual		1
Water outlet connection pipe assembly		1
Energy label		1

9.2 Hydronic Box

Table 2-9.2: Hydronic box accessories

Name	Shape	Quantity		
		SHPAI60RP24CM(-EH)	SHPAI100RP24CM(-EH)	SHPAI160RP24CM(-EH)
Service manual		1	1	1
Technical manual		1	1	1
M16 Copper Nut Tamper Cap		1	1	1
M9 Copper Nut Tamper Cap		0	1	1
M6 Copper Nut Tamper Cap		1	0	0
M8 expansion screws		5	5	5
M16 Copper nut		1	1	1
Y-shaped filter		1	1	1
Mounting bracket		1	1	1

Part 3

Installation and Field Settings

1 Preface to Part 3	35
2 Installation.....	36
3 Refrigerant Pipework	44
4 Water Pipework.....	57
5 Electrical Wiring.....	60
6 DIP Switch Settings	61
7 Internal Circulator Pump.....	61

1 Preface to Part 3

1.1 Notes for Installers Boxes

The information contained in this Technical manual may primarily be of use during the system design stage of a Centrometal Split heat pump project. Additional important information which may primarily be of use during field installation has been placed in boxes, such as the example below, titled “Notes for installers”.

Notes for installers



- Notes for installers boxes contain important information which may primarily be of use during field installation, rather than during desk-based system design.

1.2 Definitions

In this Technical manual, the term “applicable legislation” refers to all national, local and other laws, standards, codes, rules, regulations and other legislation that apply in given situation.

1.3 Precautions

All system installation including installation of refrigerant piping, water piping and electrical works must only be carried out by competent and suitably qualified, certified and accredited professionals and in accordance with all applicable legislation.

2 Installation

2.1 Acceptance and Unpacking

Notes for installers



- When units are delivered check whether any damage occurred during shipment. If there is damage to the surface or outside of unit, submit a written report to the shipping company.
- Check that the model, specifications and quantity of the units delivered are as ordered.
- Check that all accessories ordered have been included. Retain manuals for future reference.

2.2 Hoisting

Notes for installers



- Do not remove any packaging before hoisting. If units are not packaged or if the packaging is damaged, use suitable boards or packing material to protect the units.
- Hoist one unit at a time, using two ropes to ensure stability.
- Keep units upright during hoisting the outdoor unit, ensuring that the angle to the vertical does not exceed 30°.

2.3 Outdoor unit

2.3.1 Placement Considerations

Placement of the outdoor unit should take account of the following considerations:

- Outdoor units should not be exposed to direct radiation from a high-temperature heat source.
- Outdoor units should not be installed in positions where dust or dirt may affect heat exchangers.
- Outdoor units should not be installed in locations where exposure to oil or to corrosive or harmful gases, such as acidic or alkaline gases, may occur.
- Outdoor units should not be installed in locations where exposure to salinity may occur.
- Outdoor units should be installed in well-drained, well-ventilated positions.
- Outdoor units should be installed in locations where the noise from the unit will not disturb neighbors.

2.3.2 Strong Wind Installation

Wind of 5 m/s or more blowing against an outdoor unit's air outlet blocks the flow of air through the unit, leading to deterioration in unit capacity, accelerated frost accumulation when in heating mode or domestic hot water mode, and potential disruption to operation due to increased pressure in the refrigerant circuit. Exposure to very strong wind can also cause the fan to rotate excessively fast, potentially leading to damage to the fan. In locations where exposure to high winds may occur should take account of the following considerations:

- For installation of the outdoor unit in a place where the wind direction can be foreseen. Set the outlet side at a right angle to the direction of the wind, refer to Figure 3-2.1.
- If turn the outlet side toward the building's wall, fence or screen. Make sure there is enough room to do the installation.

Figure 3-2.1: Strong wind installation direction

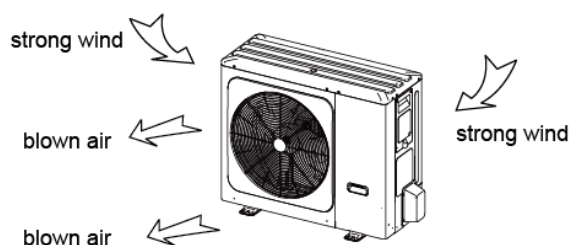

2.3.3 Cold Climate Installation

In cold climate locations installation should take account of the following considerations:

- Never install the unit at a site where the suction side may be exposed directly to wind.
- To prevent exposure to wind, install a baffle plate on the air discharge side of the unit.
- To prevent exposure to wind, install the unit with its suction side facing the wall.
- In areas of heavy snowfall, a canopy should be installed to prevent snow entering the unit.

Additionally, the height of the base structure should be increased so as to raise the unit further off the ground. Refer to Figure 3-2.2.

Figure 3-2.2: Snow shielding

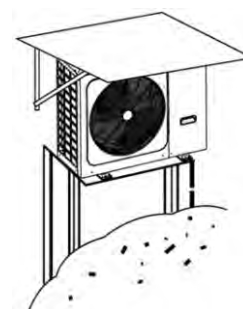

2.3.4 Hot Climate Installation

As the outdoor temperature is measured via the outdoor unit air thermistor, make sure to install the outdoor unit in the shade or a canopy should be constructed to avoid direct sunlight, so that it is not influenced by the sun's heat, otherwise protection may be possible to the unit.

2.3.5 Base Structure

Outdoor unit base structure design should take account of the following considerations:

- A solid base prevents excess vibration and noise. Outdoor unit bases should be constructed on solid ground or on structures of sufficient strength to support the unit's weight.

- Bases should be at least 100mm high to provide sufficient drainage and to prevent water ingress into the base of the unit.
- Either steel or concrete bases may be suitable.
- Outdoor units should not be installed on supporting structures that could be damaged by water build-in in the event of a blocked drain.
- Fix the unit securely to foundation by means of the $\Phi 10$ expansion bolt. It is best to screw in the foundation bolts until their length is 20 mm from the foundation surface.

Figure 3-2.3: Outdoor unit fixing

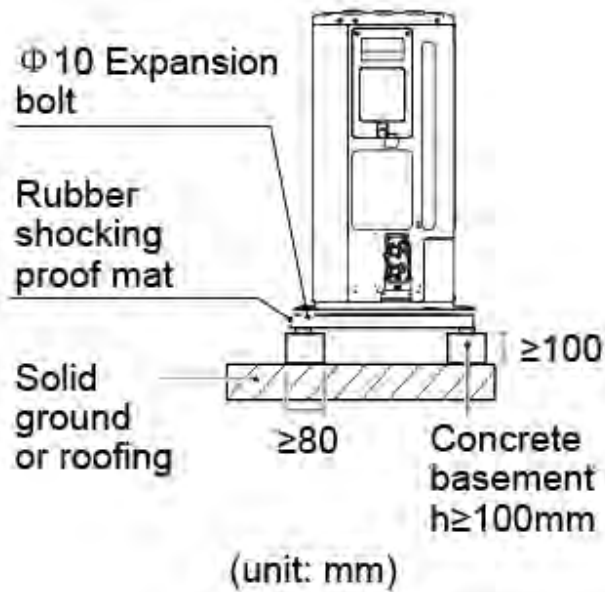

2.3.6 Drainage

Drainage ditch should be provided to allow drainage of condensate that may form on the air side heat exchanger when the unit is running in heating mode or domestic hot water mode. The drainage should ensure that condensate is directed away from roadways and footpaths, especially in locations where the climate is such that condensate may freeze.

Figure 3-2.4: 6 kW models drainage hole

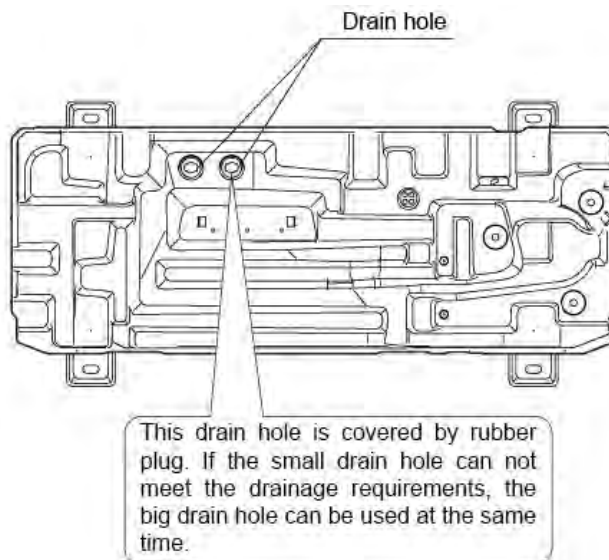
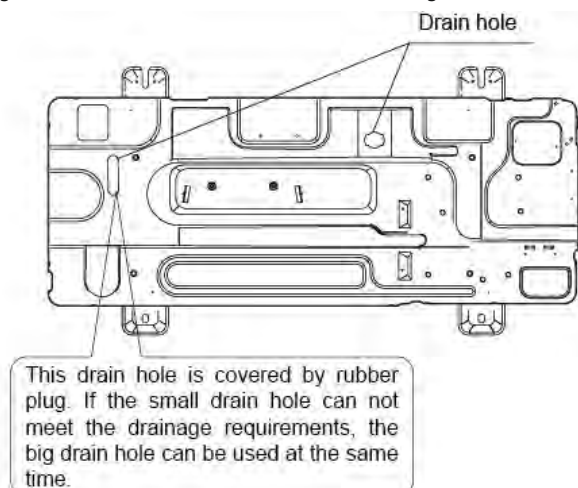

Figure 3-2.5: 10 kW and 16 kW models drainage hole



2.3.7 Transportation support

For 16kW model, there is a transportation support which is used to protect tubes from breaking during transportation and this support should be taken off before turning on the heat pump.

Figure 3-2.6: 16 kW models transportation support

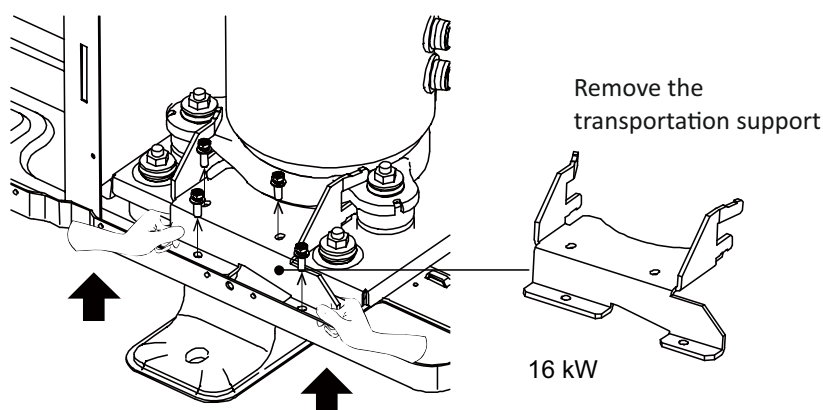

2.3.8 Spacing

Single unit installation

Outdoor unit must be spaced such that sufficient air may flow through each unit. Sufficient airflow across heat exchangers is essential for outdoor units to function properly.

Figure 3-2.7: Single unit installation requirement (unit: mm)

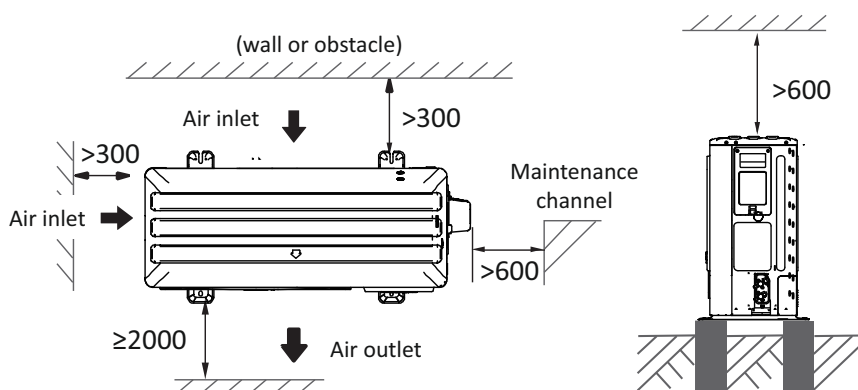

Stacked installation

Figure 3-2.8: Installation with obstacles in front of the unit

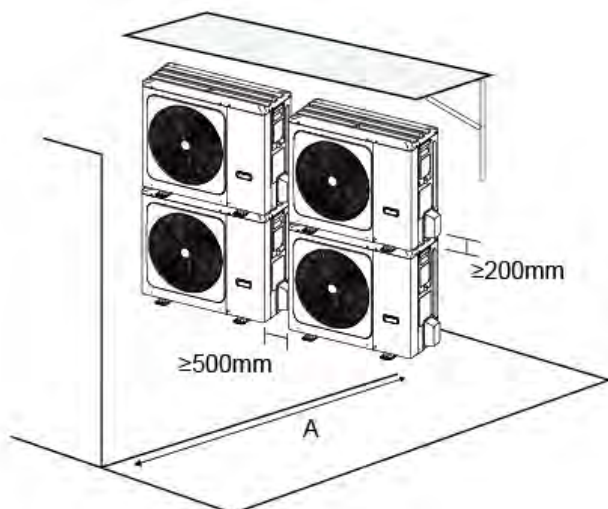
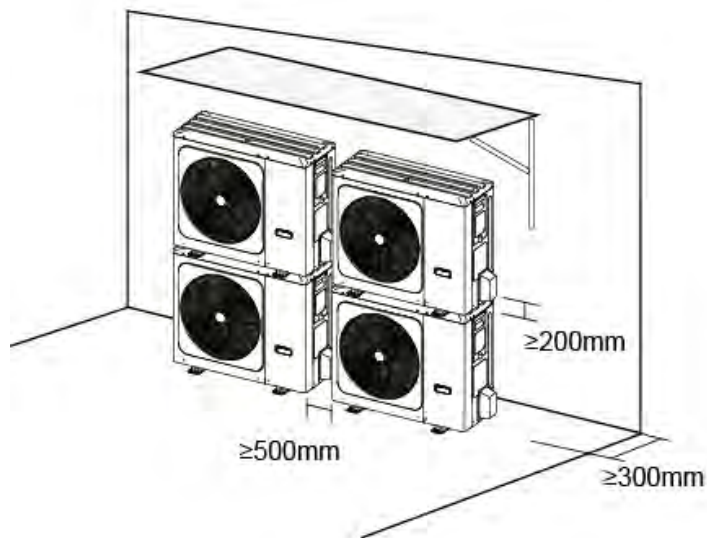

Table 3-2.1: Minimum spacing from obstacles in front of the unit

Model name	A (mm)
SHPAO6RP24CM	2000
SHPAO10RP24CM	
SHPAO16RP24P3CM	

Figure 3-2.9: Installation with obstacles behind the unit



Installation in Rows

Figure 3-2.10: Single row installation

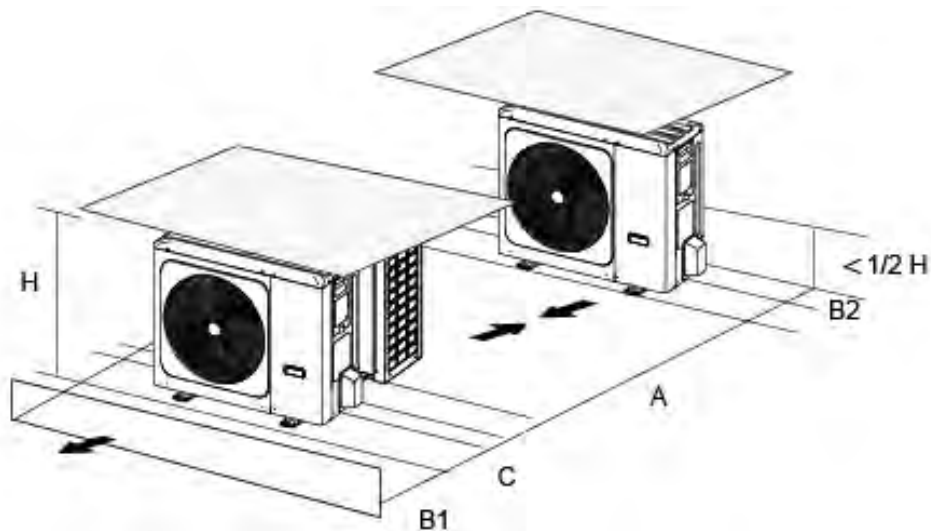

Table 3-2.2: Single row installation spacing requirements

Model name	A (mm)	B1 (mm)	B2 (mm)	C (mm)
SHPAO6RP24CM SHPAO10RP24CM SHPAO16RP24P3CM	≥3000	≥2000	≥150	≥600

Figure 3-2.11: Multi-row installation

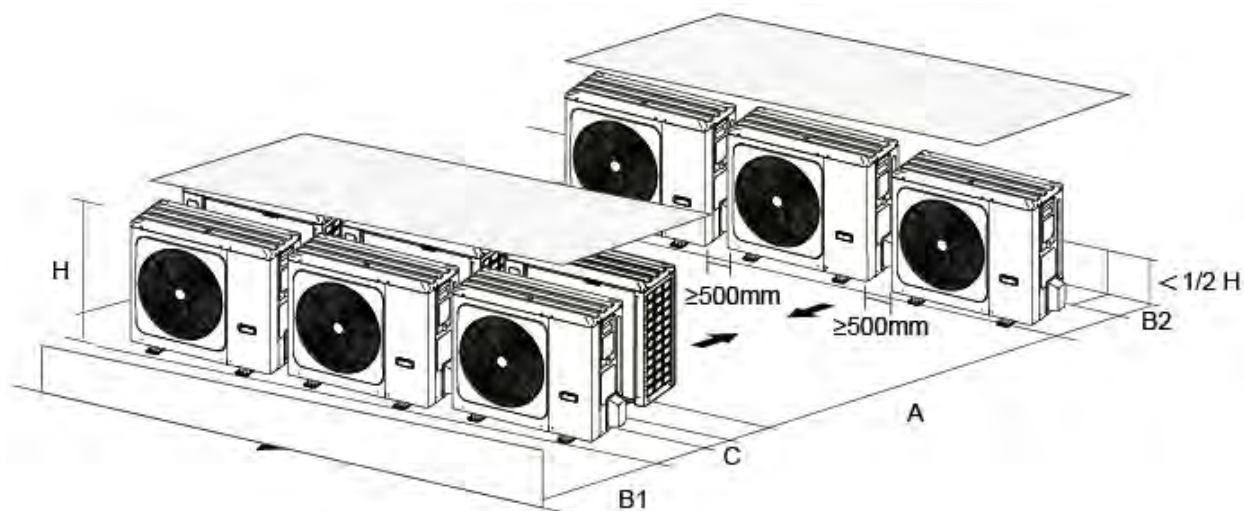

Table 3-2.3: Multiple row installation spacing requirements

Model name	A (mm)	B1 (mm)	B2 (mm)	C (mm)
SHPAO6RP24CM SHPAO10RP24CM SHPAO16RP24P3CM	≥3000	≥2000	≥300	≥600

2.4 Hydronic box

2.4.1 Placement Considerations

- Hydronic box should be installed in positions that are as close as possible to the heat emitters.
- Hydronic box should be installed in positions that are sufficiently close to the desired position of the wired controller that the controller’s wiring length limitation will not be exceeded.
- In systems that are configured to heat domestic hot water, hydronic box should be installed in positions that are sufficiently close to the domestic hot water tank that the temperature sensor wiring length limitations will not be exceeded.

2.4.2 Mounting the hydronic box

- Fix the wall mounting bracket to the wall using appropriate plugs and screws.

Figure 3-2.12: Wall bracket

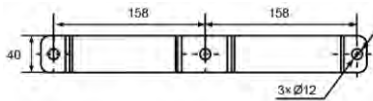
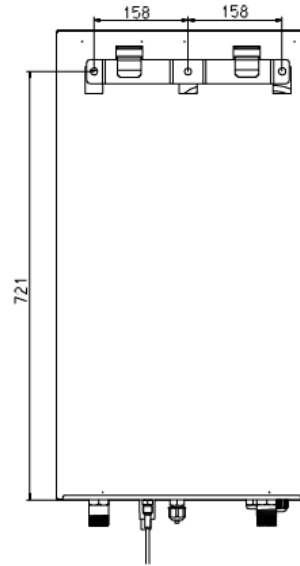
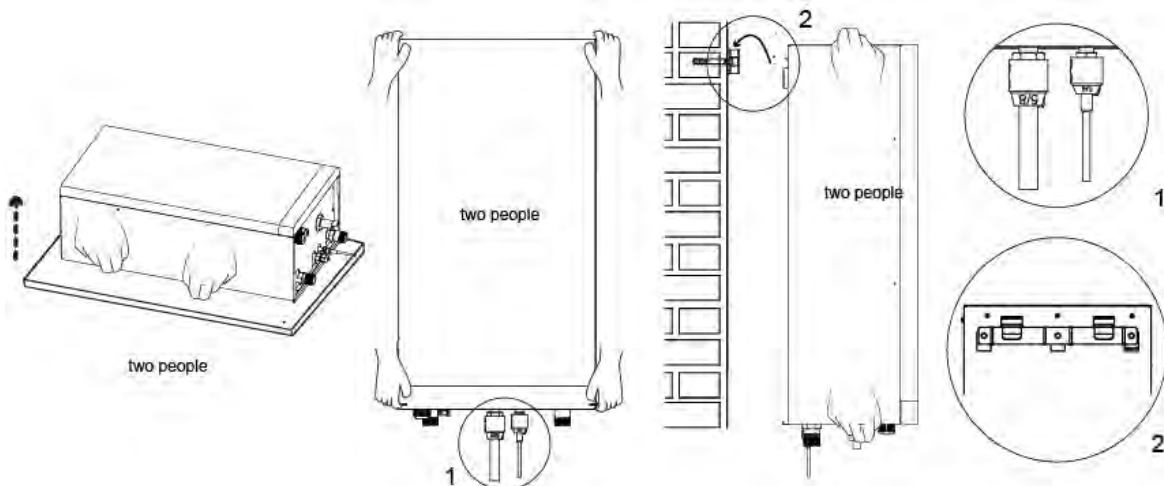

Figure 3-2.13: Hydronic box backside



- Make sure the wall mounting bracket is completely level. When the unit is not installed level, air might get trapped in the water circuit resulting in malfunctioning of the unit. Pay special attention to this when installing the hydronic box to prevent overflow of the drain pan.
- Hang the hydronic box on the wall mounting bracket.
- Fix the hydronic box at the bottom inside using appropriate plugs and screws. The hydronic box is equipped with 2 holes at the bottom outer edges of the frame.

Figure 3-2.14: Fix hydronic box



2.4.3 Service space requirement

The service space requirements refer to Figure 3-2.15.

Figure 3-2.15: Service space requirement (unit: mm)

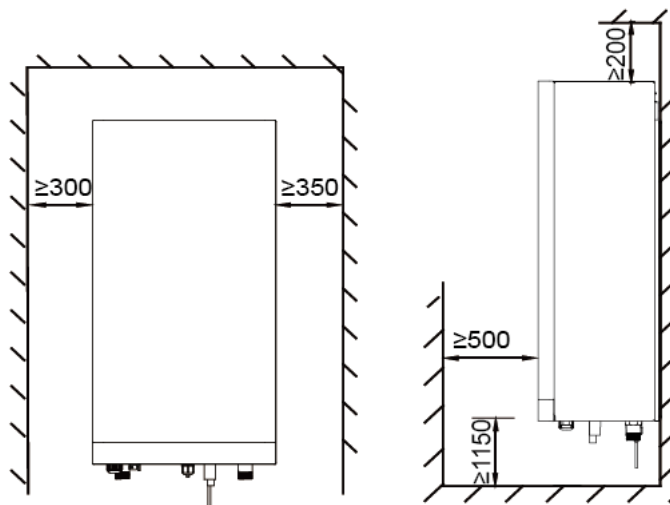

2.4.4 Drainage

The drainage connections of hydronic box refer to Figure 3-2.16.

Figure 3-2.16: Drainage

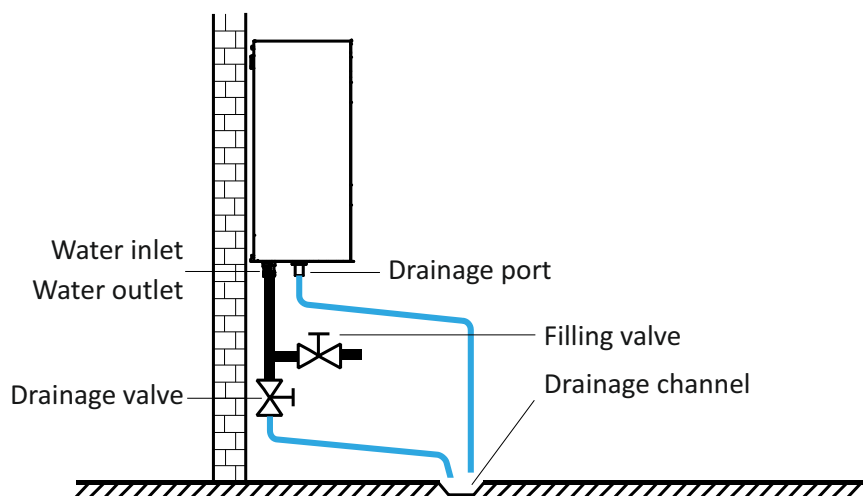

3 Refrigerant Pipework

3.1 Permitted Piping Length and Level Difference

The piping length and level difference limitations that apply are summarised in Table 3-3.1. Before installation, it is necessary to check if the piping length and height difference are meeting the requirements.

Table 3-3.1: Permitted Piping Length and Level Difference

Models	6-16 kW
Max. piping length	30 m
Max. difference in height	20 m

Figure 3-3.1: Connect method

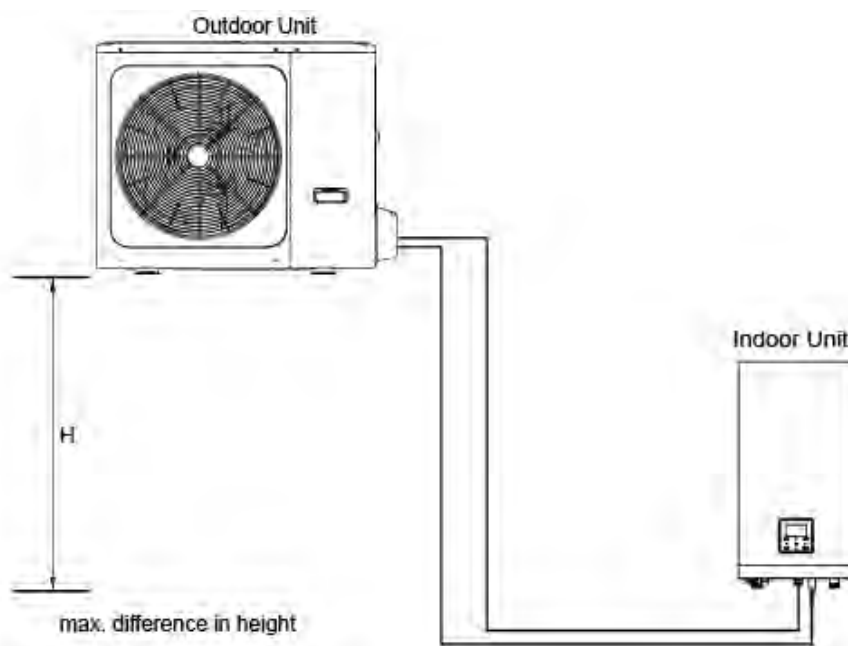

The largest level difference between indoor unit and outdoor unit should not exceed 20 m.

3.2 Pipe Size and Connect method

Table 3-3.2: Refrigerant pipe connection

Models	6 kW	10 kW	16 kW
Pipe connect			
Pipe size	Gas side (Φ15.9); Liquid side (Φ6.35)	Gas side (Φ15.9); Liquid side (Φ9.52)	Gas side (Φ15.9); Liquid side (Φ9.52)
Connect method	Flare	Flare	Flare

3.3 Procedure and Principles

3.3.1 Installation procedure

Notes for installers



Installation of the refrigerant piping system should proceed in the following order:



Note: Pipe flushing should be performed once the brazed connections have been completed with the exception of the final connections to the indoor units. That is, flushing should be performed once the outdoor units have been connected but before the indoor units are connected.

3.3.2 Three principles for refrigerant piping

	Reasons	Measures
CLEAN	Particles such as oxide produced during brazing and/or building dust can lead to compressor malfunction	<ul style="list-style-type: none"> Seal piping during storage¹ Flow nitrogen during brazing² Pipe flushing³
DRY	Moisture can lead to ice formation or oxidization of internal components leading to abnormal operation or compressor damage	<ul style="list-style-type: none"> Pipe flushing³ Vacuum drying⁴
SEALED	Imperfect seals can lead to refrigerant leakage	<ul style="list-style-type: none"> Pipe manipulation⁵ and brazing² techniques Gastightness test⁶

Notes:

- See Part 3, 3.4.1 "Pipe delivery, storage and sealing".
- See Part 3, 3.7 "Brazing".
- See Part 3, 3.8 "Pipe Flushing".
- See Part 3, 3.10 "Vaccum Drying".
- See Part 3, 3.5 "Manipulating Copper Piping".
- See Part 3, 3.9 "Gastightness Test".

3.4 Storing Copper Piping

3.4.1 Pipe delivery, storage and sealing

Notes for installers



- Ensure that piping does not get bent or deformed during delivery or whilst stored.
- On construction sites store piping in a designated location.
- To prevent dust or moisture entering, piping should be kept sealed whilst in storage and until it is about to be connected. If piping is to be used soon, seal the openings with plugs or adhesive tape. If piping is to be stored for a long time, charge the piping with nitrogen at 0.2-0.5 Mpa (2-5 bar) and seal the openings by brazing.
- Storing piping directly on the ground risks dust or water ingress. Wooden supports can be used to raise piping off the ground.
- During installation, ensure that piping to be inserted through a hole in a wall is sealed to ensure dust and/or fragments of wall do not enter.
- Be sure to seal piping being installed outdoors (especially if being installed vertically) to prevent rain entering.

3.5 Manipulating Copper Piping

3.5.1 De-oiling

Notes for installers



- Lubrication oil used during some copper pipe manufacturing processes can cause deposits to form in R32 refrigerant systems, causing system errors. Oil-free copper piping should therefore be selected. If ordinary (oily) copper piping is used, it must be cleaned with gauze dipped in tetrachloroethylene solution prior to installation.

Caution

- Never use carbon tetrachloride (CCl₄) for pipe cleansing or flushing, as doing so will seriously damage the system.

3.5.2 Cutting copper piping and removing burrs

Notes for installers



- Use a pipe cutter rather than a saw or cutting machine to cut piping. Rotate the piping evenly and slowly, applying even force to ensure that the piping does not become deformed during cutting. Using a saw or cutting machine to cut piping runs the risk of copper shavings entering the piping. Copper shavings are difficult to remove and pose a serious risk to the system if they enter the compressor or block the throttling unit.
- After cutting using a pipe cutter, use a reamer/scrapper to remove any burrs that have formed at the opening, keeping the opening of the piping downwards to avoid copper shavings from entering the piping.
- Remove burrs carefully to avoid scratches, which may prevent a proper seal being formed and lead to refrigerant leakage.

3.5.3 Expanding copper piping ends

Notes for installers



- Ends of copper piping can be expanded so that another length of piping can be inserted and the joint brazed.
- Insert the expanding head of the pipe expander into the pipe. After completing pipe expansion, rotate the copper pipe a few degrees to rectify the straight line mark left by the expanding head.

Caution

- Ensure that the expanded section of piping is smooth and even. Remove any burrs that remain after cutting.

Figure 3-3.2: Expanding copper piping ends

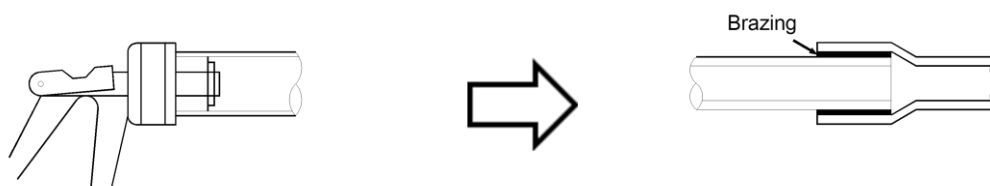

3.5.4 Flared joints

Flared joints should be used where a screw thread connection is required.

Notes for installers



- Before flaring 1/2H (half hard) piping, anneal the end of the pipe to be flared.
- Remember to place the flare nut on the piping before flaring.
- Ensure the flared opening is not cracked, deformed or scratched, otherwise it will not form a good seal and refrigerant leakage may occur.
- The diameter of the flared opening should be within the ranges specified in Table 3-3.3. Refer to Figure 3-3.3.

Table 3-3.3: Flared opening size ranges

Pipe (mm)	Flared opening diameter (A) (mm)
Φ6.35	8.7 - 9.1
Φ9.53	12.8 - 13.2
Φ12.7	16.2 - 16.6
Φ15.9	19.3 - 19.7
Φ19.1	23.6 - 24.0

Figure 3-3.3: Flared opening

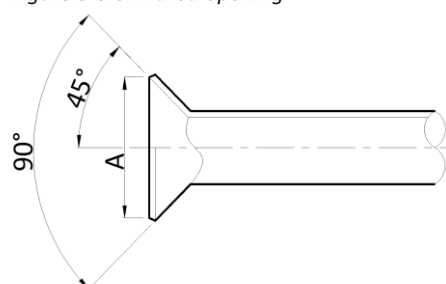

- When connecting a flared joint, apply some compressor oil to the inner and outer surfaces of the flared opening to facilitate the connection and rotation of the flare nut, ensure firm connection between the sealing surface and the bearing surface, and avoid the pipe becoming deformed.

3.5.5 Bending piping

Bending copper piping reduces the number of brazed joints required and can improve quality and save material.

Notes for installers



Piping bending methods

- Hand bending is suitable for thin copper piping ($\Phi 6.35$ mm - $\Phi 12.7$ mm).
- Mechanical bending (using a bending spring, manual bending machine or powered bending machine is suitable for a wide range of diameters ($\Phi 6.35$ mm - $\Phi 54.0$ mm).

Caution

- When using a spring bender, ensure that the bender is clean before inserting it in the piping.
- After bending a copper pipe, ensure that there are no wrinkles or deformation on either side of the pipe.
- Ensure that bend angles do not exceed 90° , otherwise wrinkles may appear on the inner side of the pipe, and the pipe may buckle or crack. Refer to Figure 3-3.4.
- Do not use a pipe that has buckled during the bending process; ensure that the cross section at the bend is greater than $2/3$ of the original area.

Figure 3-3.4: Pipe bending in excess of 90°

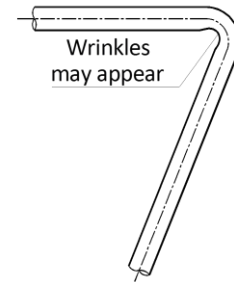

3.6 Refrigerant Piping Supports

When the heat pump is running, the refrigerant piping will deform (shrink, expand and droop). To avoid damage to piping, hangers or supports should be spaced as per the criteria in the Table 3-3.4. In general, the gas and liquid pipes should be suspended in parallel and the interval between support points should be selected according to the diameter of the gas pipe.

Table 3-3.4: Refrigerant piping support spacings

Pipe (mm)	Interval between support points (m)	
	Horizontal Piping	Vertical Piping
< $\Phi 20$	1	1.5
$\Phi 20 - \Phi 40$	1.5	2
> $\Phi 40$	2	2.5

Suitable insulation should be provided between the piping and the supports. If wooden dowels or blocks are to be used, use wood that has undergone preservative treatment.

Changes in refrigerant flow direction and refrigerant temperature result in movement, expansion and shrinkage of the refrigerant piping. Piping should therefore not be fixed too tightly, otherwise stress concentrations may occur in the piping with the potential for rupturing.

3.7 Brazing

Care must be taken to prevent oxide forming on the inside of copper piping during brazing. The presence of oxide in a refrigerant system adversely affects the operation of valves and compressors, potentially leading to low efficiency or even compressor failure. To prevent oxidation, during brazing nitrogen should be flowed through the refrigerant piping.

Notes for installers



Warning

- Never flow oxygen through piping as doing so aids oxidation and could easily lead to explosion and as such is extremely dangerous.
- Take appropriate safety precautions such as having a fire extinguisher to hand whilst brazing.

Flowing nitrogen during brazing

- Use a pressure reducing valve to flow nitrogen through copper piping at 0.02-0.03 MPa during brazing.
- Start the flow before brazing starts and ensure that the nitrogen continuously passes through the section being brazed until the brazing is complete and the copper has cooled down completely.

Figure 3-3.5: Flowing nitrogen through piping during brazing

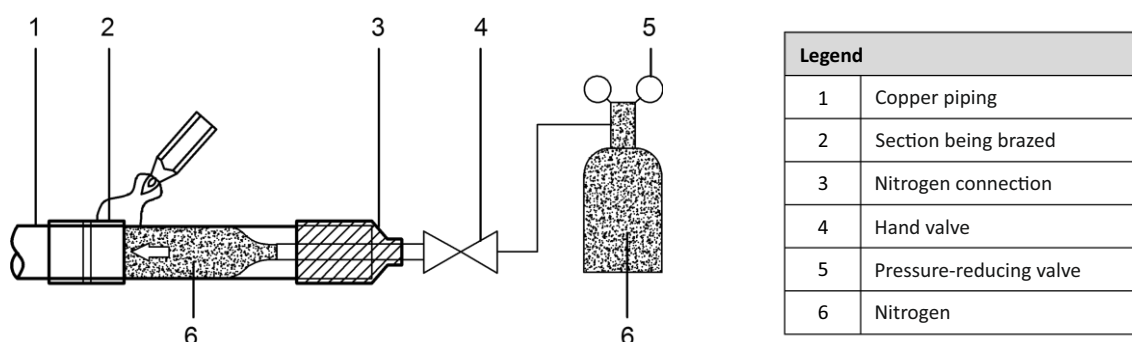

- When joining a shorter section of piping to a longer section, flow nitrogen from the shorter side to allow better displacement of air with nitrogen.
- If the distance from the point where nitrogen enters the piping to the joint to be brazed is long, ensure that the nitrogen is flowed for sufficient time to discharge all the air from the section to be brazed before commencing brazing.

Figure 3-3.6: Flowing nitrogen from shorter side during brazing

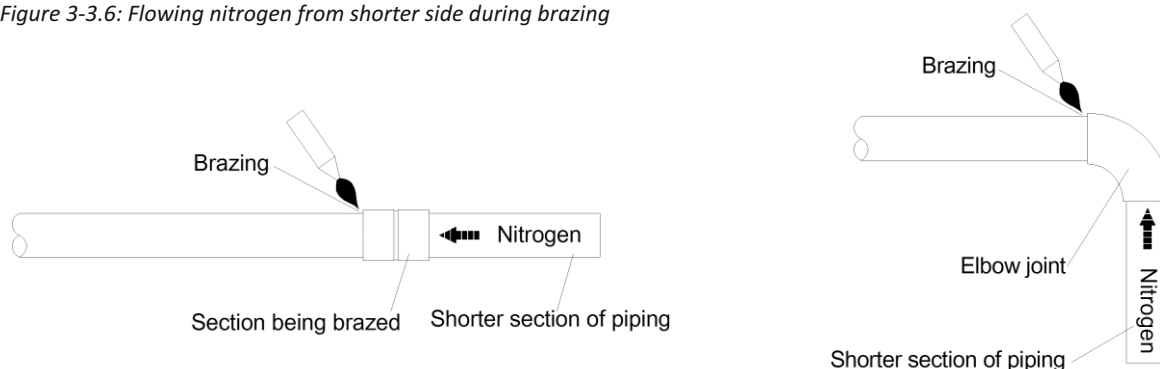

Box continued on next page...

... box continued from previous page

Piping orientation during brazing

Brazing should be conducted downwards or horizontally to avoid filler leakage.

Figure 3-3.7: Piping orientation during brazing

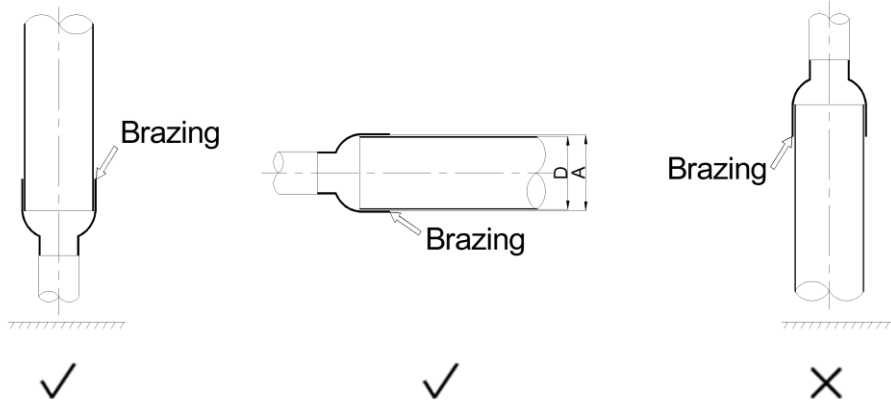

Piping overlap during brazing

Table 3-3.5 specifies the minimum permissible piping overlap and the range of permissible gap sizes for brazed joints on piping of different diameters. Refer also to Figure 3-3.8.

Figure 3-3.8: Piping overlap and gap for brazed joints

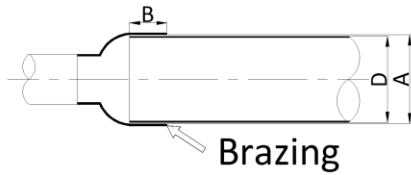

Legend	
A	Inner diameter of larger pipe
D	Outer diameter of smaller pipe
B	Inlaid depth (overlap)

Table 3-3.5: Piping overlap and gap for brazed joints¹

D (mm)	Minimum permissible B (mm)	Permissible A - D (mm)
5 < D < 8	6	0.05 - 0.21
8 < D < 12	7	
12 < D < 16	8	0.05 - 0.27
16 < D < 25	10	
25 < D < 35	12	0.05 - 0.35
35 < D < 45	14	

Notes:

1. A, B, D refer to the dimensions shown in Figure 3-5.7

Filler

- Use a copper/phosphorus brazing alloy (BCuP) filler that does not require flux.
- Do not use flux. Flux can cause corrosion of piping and can affect the performance of compressor oil.
- Do not use anti-oxidants when brazing. Residue can clog piping and damage components.

3.8 Pipe Flushing

3.8.1 Purpose

To remove dust, other particles and moisture, which could cause compressor malfunction if not flushed out before the system is run, the refrigerant piping should be flushed using nitrogen. As described in Part 3, 3.3.1 "Installation procedure", pipe flushing should be performed once the piping connections have been completed with the exception of the final connections to the hydronic box. That is, flushing should be performed once the outdoor unit have been connected but before the hydronic box is connected.

3.8.2 Procedure

Notes for installers



Warning

Only use nitrogen for flushing. Using carbon dioxide risks leaving condensation in the piping. Oxygen, air, refrigerant, flammable gases and toxic gases must not be used for flushing. Use of such gases may result in fire or explosion.

Procedure

The liquid and gas sides can be flushed simultaneously; alternatively, one side can be flushed first and then Steps 1 to 6 repeated, for the other side. The flushing procedure is as follows:

1. Attach a pressure reducing valve to a nitrogen cylinder.
2. Connect the pressure reducing valve outlet to the inlet on the liquid (or gas) side of the outdoor unit.
3. Start to open the nitrogen cylinder valve and gradually increase the pressure to 0.5 MPa.
4. Allow time for nitrogen to flow as far as the opening at hydronic box.
5. Flush the opening:
 - a) Using suitable material, such as a bag or cloth, press firmly against the opening at hydronic box.
 - b) When the pressure becomes too high to block with your hand, suddenly remove your hand allowing gas to rush out.
 - c) Repeatedly flush in this manner until no further dirt or moisture is emitted from the piping. Use a clean cloth to check for dirt or moisture being emitted. Seal the opening once it has been flushed.
6. Once flushing is complete, seal the opening to prevent dust and moisture from entering.

Figure 3-3.9: Pipe flushing using nitrogen

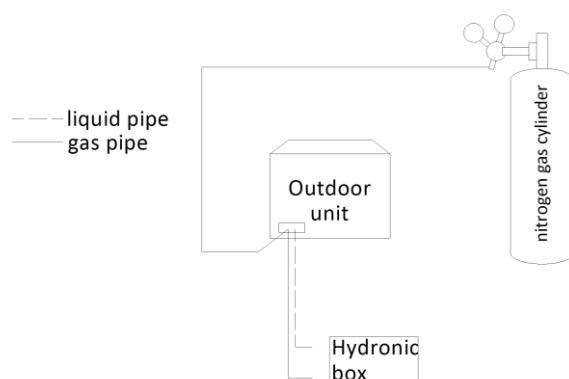

3.9 Gastightness Test

3.9.1 Purpose

To prevent faults caused by refrigerant leakage, a gastightness test should be performed before system commissioning.

3.9.2 Procedure

Notes for installers



Warning

Only dry nitrogen should be used for gastightness testing. Oxygen, air, flammable gases and toxic gases must not be used for gastightness testing. Use of such gases may result in fire or explosion.

Procedure

The gastightness test procedure is as follows:

Step 1

- Once the piping system is complete and the hydronic box and outdoor unit have been connected, vacuum the piping to -0.1 MPa.

Step 2

- Charge the piping with nitrogen at 0.3 MPa (3 bar) and leave for at least 3 minutes to check large leakage, then 1.5 MPa (15 bar) leave for at least 3 minutes to check small leakage, finally 4.3 MPa (43 bar) leave for at least 24 hours to check micro leakage.
- After the test period of at least 24 hours, observe the pressure in the piping and assess whether or not the observed pressure indicates the presence of a leak. Allow for any change in ambient temperature over the test period by adjusting the reference pressure by 0.01 MPa (0.1 bar) per 1°C of temperature difference. Adjusted reference pressure = Pressure at pressurization + (temperature at observation - temperature at pressurization) x 0.01 MPa (0.1 bar). Compare the observed pressure with the adjusted reference pressure. If they are the same, the piping has passed the gastightness test.
- If the observed pressure is lower than the adjusted reference pressure, the piping has failed the test. Refer to Part 3, 3.9.3 "Leak detection". Once the leak has been found and fixed, the gastightness test should be repeated.

Step 3

- If not continuing straight to vacuum drying (see Part 3, 3.10 "Vacuum Drying") once the gastightness test is complete, reduce the system pressure to 0.5 - 0.8 MPa (5 - 8 bar) and leave the system pressurized until ready to carry out the vacuum drying procedure.

Figure 3-3.10: Gastightness test

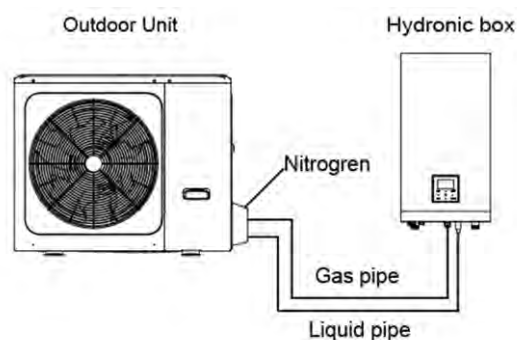

3.9.3 Leak detection

Notes for installers



The general methods for identifying the source of a leak are as follows:

1. Audio detection: relatively large leaks are audible.
2. Touch detection: place your hand at joints to feel for escaping gas.
3. Soapy water detection: small leaks can be detected by the formation of bubbles when soapy water is applied to a joint.

Figure 3-3.11: Leak detection

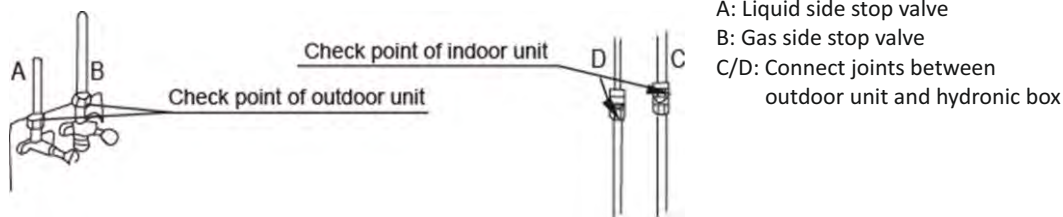

4. Refrigerant leak detection: for leaks that are difficult to detect, refrigerant leak detection may be used as follows:
 - a) Pressurize the piping with nitrogen at 0.3 MPa (3 bar).
 - b) Add refrigerant into the piping until the pressure reaches 0.5 MPa (5 bar).
 - c) Use a halogen refrigerant detector to find the leak.
 - d) If the leak source cannot be found, continue charging with refrigerant to a pressure of 4.3 MPa (43 bar) and then search again.

3.10 Vacuum Drying

3.10.1 Purpose

Vacuum drying should be performed in order to remove moisture and non-condensable gases from the system. Removing moisture prevents ice formation and oxidization of copper piping or other internal components. The presence of ice particles in the system would cause abnormal operation, whilst particles of oxidized copper can cause compressor damage. The presence of non-condensable gases in the system would lead to pressure fluctuations and poor heat exchange performance.

Vacuum drying also provides additional leak detection (in addition to the gas tightness test).

3.10.2 Procedure

Notes for installers



During vacuum drying, a vacuum pump is used to lower the pressure in the piping to the extent that any moisture present evaporates. At 5 mmHg (755 mmHg below typical atmospheric pressure) the boiling point of water is 0°C. Therefore a vacuum pump capable of maintaining a pressure of -755 mmHg or lower should be used. Using a vacuum pump with a discharge in excess of 4 L/s and a precision level of 0.02 mmHg is recommended.

Caution

- Before performing vacuum drying, make sure that the outdoor unit stop valves are firmly closed.
- Once the vacuum drying is complete and the vacuum pump is stopped, the low pressure in the piping could suck vacuum pump lubricant into the air conditioning system. The same could happen if the vacuum pump stops unexpectedly during the vacuum drying procedure. Mixing of pump lubricant with compressor oil could cause compressor malfunction and a one-way valve should therefore be used to prevent vacuum pump lubricant seeping into the piping system.

Procedure

The vacuum drying procedure is as follows:

Step 1

- Connect the blue (low pressure side) hose of a pressure gauge to the outdoor unit gas pipe stop valve, the red (high pressure side) hose to the outdoor unit liquid pipe stop valve and the yellow hose to the vacuum pump.

Step 2

- Start the vacuum pump and then open the pressure gauge valves to start vacuum the system.
- After 30 minutes, close the pressure gauge valves.
- After a further 5 to 10 minutes check the pressure gauge. If the gauge has returned to zero, check for leakages in the refrigerant piping.

Step 3

- Re-open the pressure gauge valves and continue vacuum drying for at least 2 hours and until a pressure difference of 756 mmHg or more has been achieved. Once the pressure difference of at least 756 mmHg has been achieved, continue vacuum drying for 2 hours.

Step 4

- Close the pressure gauge valves and then stop the vacuum pump.
- After 1 hour, check the pressure gauge. If the pressure in the piping has not increased, the procedure is finished. If the pressure has increased, check for leakages.
- After vacuum drying, **keep the blue and red hoses connected to the pressure gauge and to the outdoor unit stop valves**, in preparation for refrigerant charging (see Part 3, 3.11 "Charging Refrigerant").

Figure 3-3.12: Pressure gauge



3.11 Charging Refrigerant

3.11.1 Calculating additional refrigerant charge

Calculate the added refrigerant according to the diameter and the length of the liquid side pipe of the outdoor unit / indoor unit connection. If the length of the liquid side pipe is less than 15 meters it is no need to add more refrigerant, so calculating the added refrigerant the length of the liquid side pipe must subtract 15 meters.

Table 3-3.6: Additional refrigerant charge

Refrigerant to be added	Model	L (m)	
		≤ 15 m	> 15 m
Total additional refrigerant	6 kW	0 g	(L-15)*20g
	10/16 kW	0 g	(L-15)*38g

3.11.2 Adding refrigerant

Notes for installers



Caution

- Only charge refrigerant after performing a gas tightness test and vacuum drying.
- Never charge more refrigerant than required as doing so can lead to liquid hammering.
- Only use refrigerant R32 - charging with an unsuitable substance may cause explosions or accidents.
- Use tools and equipment designed for use with R32 to ensure required pressure resistance and to prevent foreign materials from entering the system.
- Refrigerant must be treated in accordance with applicable legislation.
- Always use protective gloves and protect your eyes when charging refrigerant.
- Open refrigerant containers slowly.
- Keep the site well ventilated, no ignition source and fire extinguisher in hand for R32 is a flammable refrigerant.

Procedure

The procedure for adding refrigerant is as follows:

Step 1

- Calculate additional refrigerant charge R (kg) (see Part 3, 3.11.1 “Calculating Additional Refrigerant Charge”).

Step 2

- Place a tank of R32 refrigerant on a weighing scale. Turn the tank upside down to ensure refrigerant is charged in a liquid state.
- After vacuum drying (see Part 3, 3.10 “Vacuum Drying”), the blue and red pressure gauge hoses should still be connected to the pressure gauge and to the outdoor unit stop valves.
- Connect the yellow hose from the pressure gauge to the R32 refrigerant tank.

Step 3

- Open the valve where the yellow hose meets the pressure gauge, and open the refrigerant tank slightly to let the refrigerant eliminate the air. Caution: open the tank slowly to avoid freezing your hand.
- Set the weighing scale to zero.

Box continued on next page...

... box continued from previous page

Step 4

- Open the three valves on the pressure gauge to begin charging refrigerant.
- When the amount charged reaches R (kg), close the three valves. If the amount charged has not reached R (kg) but no additional refrigerant can be charged, close the three valves on the pressure gauge, run the outdoor unit in cooling mode, and then open the yellow and blue valves. Continue charging until the full R (kg) of refrigerant has been charged, then close the yellow and blue valves. Note: Before running the system, be sure to complete all test run checks as listed in Part 3, 8.15 "TEST RUN" and be sure to open stop valves as running the system with the stop valves closed would damage the compressor.

Figure 3-3.13: Charging refrigerant

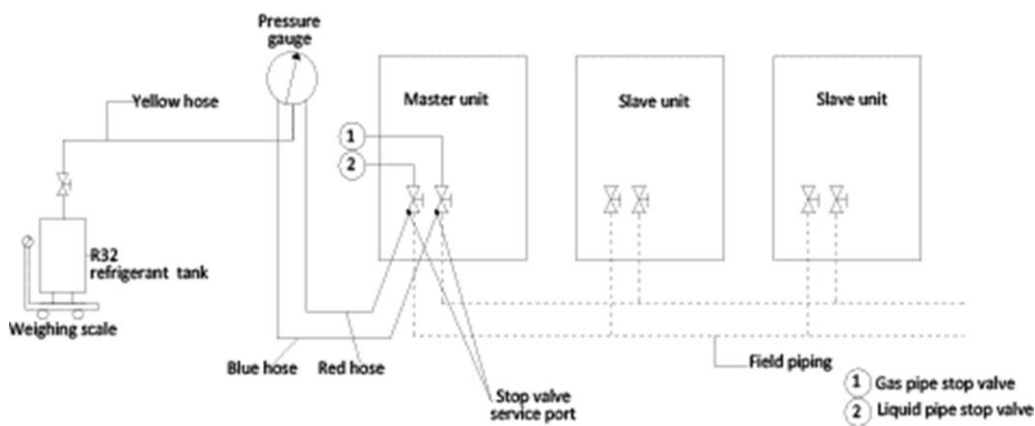

Pressure gauge

4 Water Pipework

4.1 Water Circuit Checks

Hydronic boxes are equipped with a water inlet and outlet for connection to a water circuit. Centrometal Split units should only be connected to closed water circuits. Connection to an open water circuit would lead to excessive corrosion of the water piping. Only materials complying with all applicable legislation should be used.

Before continuing installation of the unit, check the following:

- The maximum water pressure ≤ 3 bar.
- The maximum water temperature $\leq 70^{\circ}\text{C}$ according to safety device setting.
- Always use materials that are compatible with the water used in the system and with the materials used in the unit.
- Ensure that components installed in the field piping can withstand the water pressure and temperature.
- Drain taps must be provided at all low points of the system to permit complete drainage of the circuit during maintenance.
- Air vents must be provided at all high points of the system. The vents should be located at points that are easily accessible for service. An automatic air purge is provided inside the unit. Check that this air purge valve is not tightened so that automatic release of air in the water circuit is possible.

4.2 Water volume and sizing expansion vessels

The units are equipped with an expansion vessel of 8L that has a default pre-pressure of 1.5 bar. To assure proper operation of the unit, the pre-pressure of the expansion vessel might need to be adjusted.

- Check that the total water volume in the installation, excluding the internal water volume of the unit, is at least 40L.
- Expansion vessel volume must fit the total water system volume.
- To size the expansion for the heating and cooling circuit.

The expansion vessel volume can follow the figure below:

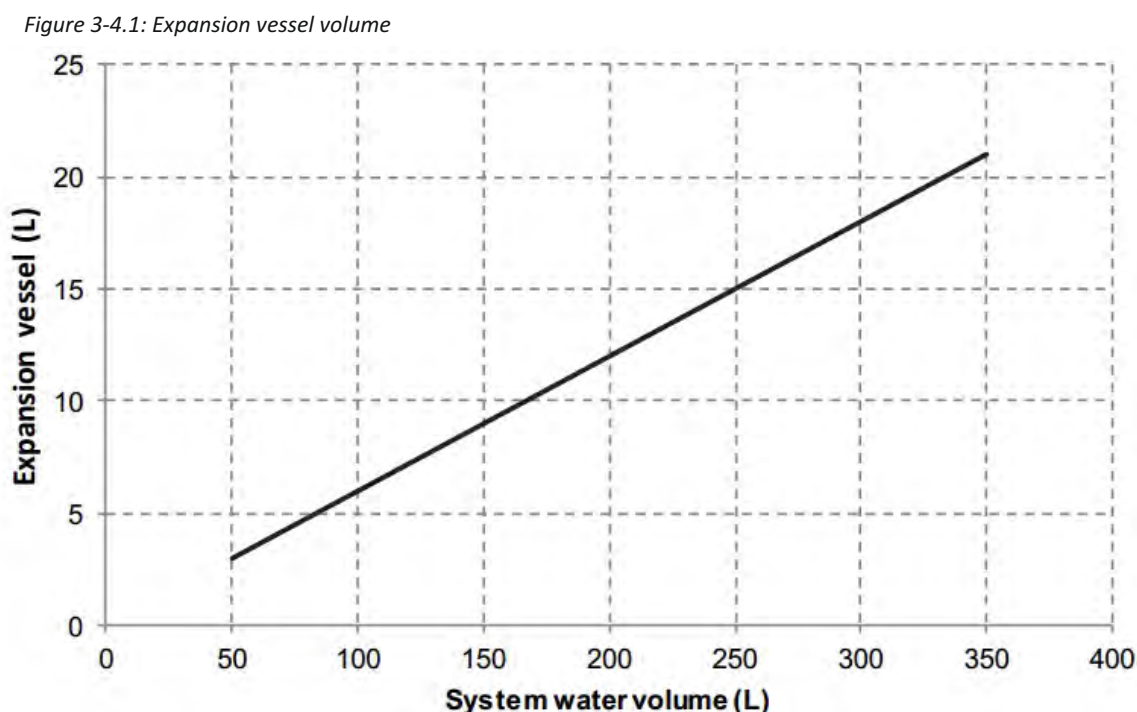

Notes:

- In most applications this minimum water volume will be satisfactory.
- In critical processes or in rooms with a high heat load though, extra water might be required.
- When circulation in each space heating loop is controlled by remotely controlled valves, it is important that this minimum water volume is kept even if all the valves are closed.

4.3 Water Circuit Connection

Water connections must be made correctly in accordance with the labels on the hydronic box, with respect to the water inlet and water outlet. If air, moisture or dust gets in the water circuit, problems may occur. Therefore, always take into account the following when connecting the water circuit:

- Use clean pipes only.
- Hold the pipe end downwards when removing burrs.
- Cover the pipe end when inserting it through a wall to prevent dust and dirt entering.
- Use a good thread sealant for sealing the connections. The sealing must be able to withstand the pressures and temperatures of the system.
- When using non-copper metallic piping, be sure to insulate the two kinds of materials from each other to prevent galvanic corrosion.
- For copper is a soft material, use appropriate tools for connecting the water circuit. Inappropriate tools will cause damage to the pipes.

4.4 Water Circuit Anti-freeze Protection

Ice formation can cause damage to the hydronic system. All internal hydronic parts are insulated to reduce heat loss. Insulation must also be added to the field piping.

- The software contains special functions using the heat pump to protect the entire system against freezing. When the temperature of the water flow in the system drops to a certain value, the unit will heat the water, either using the heat pump, the electric heating tap, or the backup heater. The freeze protection function will turn off only when the temperature increases to a certain value.
- In event of a power failure, the above features would not protect the unit from freezing.
Since a power failure could happen when the unit is unattended, the supplier recommends use anti-freeze fluid to the water system.
- Depending on the expected lowest outdoor temperature, make sure the water system is filled with a concentration of glycol as mentioned in the table below. When glycol is added to the system, the performance of the unit will be affected. The correction factor of the unit capacity, flow rate and pressure drop of the system is listed in the table 3-4.1 and 3-4.2.

Table 3-4.1: Ethylene Glycol

Concentration of ethylene glycol (%)	Modification coefficient				Minimum outdoor temperature (°C)
	Cooling capacity modification	Power input modification	Water resistance	Water flow modification	
0	1.000	1.000	1.000	1.000	0
10	0.984	0.998	1.118	1.019	-5
20	0.973	0.995	1.268	1.051	-15
30	0.965	0.992	1.482	1.092	-25

Table 3-4.2: Propylene Glycol

Concentration of propylene glycol (%)	Modification coefficient				Minimum outdoor temperature (°C)
	Cooling capacity modification	Power input modification	Water resistance	Water flow modification	
0	1.000	1.000	1.000	1.000	0
10	0.976	0.996	1.071	1.000	-4
20	0.961	0.992	1.189	1.016	-12
30	0.948	0.988	1.380	1.034	-20

Uninhibited glycol will turn acidic under the influence of oxygen. This process is accelerated by presence of copper and at higher temperatures. The acidic uninhibited glycol attacks metal surfaces and forms galvanic corrosion cells that cause severe damage to the system. It is of extreme importance:

- That the water treatment is correctly executed by a qualified water specialist;
- That a glycol with corrosion inhibitors is selected to counteract acids formed by the oxidation of glycols;
- That in case of an installation with a domestic hot water tank, only the use of propylene glycol is allowed. In other installations the use of ethylene glycol is fine;
- That no automotive glycol is used because their corrosion inhibitors have a limited lifetime and contain silicates that can foul or plug the system;
- That galvanized piping is not used in glycol systems since it may lead to the precipitation of certain elements in the glycol's corrosion inhibitor;
- To ensure that the glycol is compatible with the materials used in the system.

4.5 Water Flow Switch

Water may enter into the flow switch and cannot be drained out and may freeze when the temperature is low enough. The flow switch should be removed and dried, then can be reinstalled in the unit.

- Counterclockwise rotation, remove the water flow switch.
- Drying the water flow switch completely.

Figure 3-4.2: Water flow switch

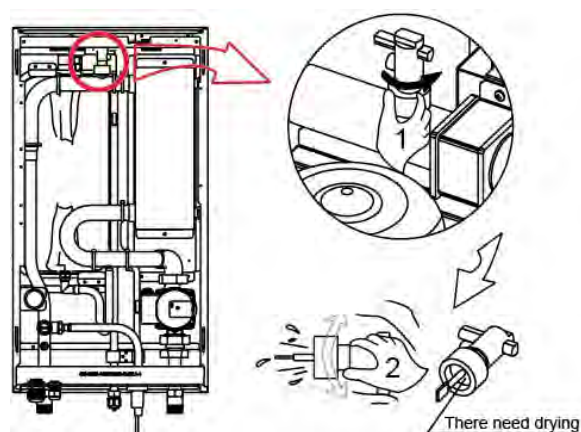

4.6 Adding Water

- Connect the water supply to the fill valve and open the valve.
- Make sure the automatic air purge valve is open (at least 2 turns).
- Fill with water until the manometer indicates a pressure of approximately 2.0 bars. Remove air in the circuit as much as possible using the air purge valve. Air in the water circuit could lead to malfunction of the backup electric heater.

4.7 Water Piping Insulation

The complete water circuit including all piping, water piping must be insulated to prevent condensation during cooling operation and reduction of the heating and cooling capacity as well as prevention of freezing of the outside water piping during winter. The insulation material should at least of B1 fire resistance rating and complies with all applicable legislation. The thickness on the sealing materials must be at least 13 mm with thermal conductivity 0.039 W/mK in order to prevent freezing on the outside water piping. If the outdoor ambient temperature is higher than 30°C and the humidity is higher than RH 80%, the thickness of the sealing materials should be at least 20 mm in order to avoid condensation on the surface of the seal.

5 Electrical Wiring

5.1 General

Notes for installers



Caution

- All installation and wiring must be carried out by competent and suitably qualified, certified and accredited professionals and in accordance with all applicable legislation.
- Electrical systems should be grounded in accordance with all applicable legislation.
- Overcurrent circuit breakers and residual-current circuit breakers (ground fault circuit interrupters) should be used in accordance with all applicable legislation.
- Wiring patterns shown in this data book are general connection guides only and are not intended for, or to include all details for, any specific installation.
- The water piping, power wiring and communication wiring are typically run in parallel. However the communication wiring should not be bound together with power wiring. To prevent signal interference, the power wiring and communication wiring should not be run in the same conduit. If the power supply is less than 10A, a separation of at least 300 mm between power wiring and communication wiring conduits should be maintained; if the power supply is in the range 10A to 50A then a separation of at least 500 mm should be maintained.

5.2 Precautions

- Fix cables so that cables do not make contact with the pipes (especially on the high pressure side).
- Secure the electrical wiring with cable ties so that it does not come in contact with the piping, particularly on the high-pressure side.
- Make sure no external pressure is applied to the terminal connectors.
- When installing the ground fault circuit interrupter make sure that it is compatible with the inverter (resistant to high frequency electrical noise) to avoid unnecessary opening of the ground fault circuit interrupter.
- This unit is equipped with an inverter. Installing a phase advancing capacitor not only reduce the power factor improvement effect, but also may cause abnormal heating of the capacitor due to high frequency waves. Never install a phase advancing capacitor as it could lead to an accident.

5.3 Guidance

- Most field wiring on the unit is to be made on the terminal block inside the switch box. To gain access to the terminal block, remove the switch box service panel.
- Fix all cables using cable ties.
- A dedicated power circuit is required for the backup electric heater.
- Installation equipped with a domestic hot water tank (field supplied) requires a dedicated power circuit for the immersion heater.



Secure the wiring in the order shown below:

- Lay out the electrical wiring so that the front cover does not rise up when doing wiring work and attach the front cover securely.
- Follow the electric wiring diagrams for electrical wiring works. Refer to Figure 2-4.1 to Figure 2-4.5 in Part 2, 4 "Wiring Diagram".
- Install the wires and fix the cover firmly so that the cover may be fit in properly.

6 DIP Switch Settings

DIP switch S1, S2 is located on the hydraulic module main control board and allows configuration of additional heating source thermistor installation, the second inner backup heater installation, etc. Refer to Table 3-6.1 and to the Centrometal Split Service Manual, Part 4, 2.2 “Main PCB for Hydronic System”.

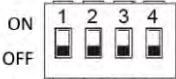
Table 3-6.1: DIP switch settings

Switch		ON=1	OFF=0	Default factory setting
S1 	1/2	0/0 = IBH (One-stage control) 0/1 = 6 kW IBH (Two-stage control) 1/1 = 9 kW IBH (Three-stage control)		OFF/OFF
	3/4	0/0 = Without IBH and AHS 1/0 = With IBH 0/1 = With AHS for heating mode 1/1 = With AHS for heating mode and DHW mode		OFF/OFF
S2 	1	Start pumpo after six hours will be invalid	Start pumpo after six hours will be valid	OFF
	2	without TBH	with TBH	OFF
	3/4	00 = variable speed pump (Max. head: 8.5 m, Grundfos) 01 = constant speed pump (Wilo) 10 = variable speed pump (Max. head: 10.5 m, Grundfos) 11 = variable speed pump (Max. head: 9.0 m, Wilo)		ON/ON
S4 	1	Reserved	Reserved	OFF
	2	Reserved	Reserved	OFF
	3/4	Reserved		OFF/OFF

7 Internal Circulation Pump

The pump is controlled via a digital low-voltage pulse-width modulation signal which means that the speed of rotation depends on the input signal. The speed changes as a function of the input profile. The relationship between external static pressure and water flow rate is described in Part 2,7 “Hydronic Performance”.

Figure 3-7.1: Internal circulator pump

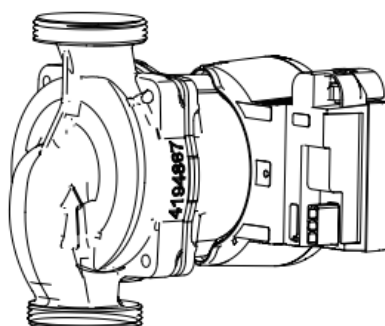



Company assumes no responsibility for possible inaccuracies in this book originated typographical errors or rewriting. All the pictures and diagrams are principal and it is necessary to adjust each actual situation on the field, in any case the company reserves the right to enter their own products such modifications as considered necessary.

Centrometal d.o.o. Glavna 12, 40306 Macinec, Croatia

central tel: +385 40 372 600, fax: +385 40 372 611
service tel: +385 40 372 622, fax: +385 40 372 621

www.centrometal.hr
e-mail: servis@centrometal.hr

Centrometal
HEATING TECHNIQUE
