

## Technical data - EKO-CK P + Cm Pelet-set 14-50

Model identifier (TYPE):		EKO-CK P 20 + Cm Pelet-set 14	EKO-CK P 25 + Cm Pelet-set 35	EKO-CK P 30 + Cm Pelet-set 35	EKO-CK P 35 + Cm Pelet-set 35	EKO-CK P 40 + Cm Pelet-set 35	EKO-CK P 50 + Cm Pelet-set 50	EKO-CK P 60 + Cm Pelet-set 50	
Useful heat output at rated heat output - P <sub>n</sub>	(kW)	14	20	25	30	35	40	50	
Useful heat output at 30 % of rated heat output - P <sub>p</sub>	(kW)	4.2	6	7.5	9	10.5	12	15	
Useful efficiency at rated heat output (lower calorific value)	(%)	90.3	91.6	92.7	92.4	92.2	91.9	91.4	
Useful efficiency at 30 % of rated heat output (lower calorific value)	(%)	90.0	90.8	91.5	91.6	91.6	91.7	91.8	
Useful efficiency at rated heat output (gross calorific value „GCV“) -η <sub>n</sub>	(%)	82.6	84.1	85.4	85.2	84.9	84.7	84.2	
Useful efficiency at 30 of rated heat output (gross calorific value „GCV“) -η <sub>p</sub>	(%)	82.3	83.4	84.3	84.4	84.4	84.5	84.6	
Heat output range	(kW)	4.2-14	6-20	7.5-25	9-30	10,5-35	12-40	15-50	
Boiler		EKO-CK P 20	EKO-CK P 25	EKO-CK P 30	EKO-CK P 35	EKO-CK P 40	EKO-CK P 50	EKO-CK P 60	
Burner		CPPL-14	CPPL-35	CPPL-35	CPPL-35	CPPL-35	CPPL-50	CPPL-50	
Feeder screw		CPPT	CPPT	CPPT	CPPT	CPPT	CPPT-50	CPPT-50	
Pellet tank		CPSP	CPSP	CPSP	CPSP	CPSP	CPSP	CPSP	
Boiler class		5							
Required chimney underpressure	(mbar)	0.11	0.12	0.13	0.14	0.15	0.20	0.22	
Required chimney underpressure at min. power	(mbar)	0.05							
Water amount in boiler	(l)	60	64	67	76	78	96	118	
Exhaust gas temperature at nominal heat output	(°C)	160							
Exhaust gas temperature at min. heat output	(°C)	130							
Exhaust mass flow at nominal heat output	(kg/s)	0.01309	0.01874	0.02345	0.02815	0.03284	0.03754	0.04694	
Exhaust mass flow at minimum heat output	(kg/s)	0.0079	0.01111	0.01381	0.01702	0.01984	0.02267	0.02757	
Standby heat losses	(kW)	0,15	0,217	0,266	0,288	0,309	0,34	0,43	
Boiler resistance on water side at nominal output *	(mbar)	2,2-0,5	4,4-1,1	6,9-1,7	10-2,5	13,6-3,4	17,7-4,4	27,7-6,9	
Burning period at nominal power	(h)	6							
Temperature setting range by help of the regulation **	(°C)	70-90 / 75-90 / 80-90							
Lowest return temperature	(°C)	55							
Maximum heat input	(kW)	15,6	22,2	27,8	33,33	38,88	44,44	55,55	
Fuel size		fi 6 x max 50							
Combustion chamber volume / pellet tank volume	(l)	75,4/370	80/370	92,5/370	105/370	116/370	161/370	167/370	
Combustion chamber dimension	(mm)	321x506x550	321x541x550	371x541x550	421x541x550	471x541x550	471x664x550	471x664x650	
Combustion chamber volume	(l)	89,3	95,5	110,3	125,2	140	172	203,2	
Combustion chamber type		overpressure							
Electrical power	(W)	250							
Voltage	(V~)	230							
Frequency	(Hz)	50							
Type of current		~							
Boiler dimensions with casing	Length (A)	(mm)	985	1020	1020	1020	1020	1142	1142
	Width (B)	(mm)	470	470	520	570	620	620	620
	Height (C)	(mm)	1255	1255	1255	1255	1255	1255	1355
Boiler body mass	(kg)	203	210	230	241	267	310	327	
Total mass - (boiler with casing and accessories)	(kg)	227	234	255	266	293	337	355	
Max. operating overpressure	(bar)	2,5							
Test pressure	(bar)	5,5							
Max. operating temperature	(°C)	90							
Uptake tube - external diameter	(mm)	150	150	160	160	180	180	180	
Boiler connections	Flow and return pipe (male thread)	(R)	5/4"						
	Charge/discharge (female thread)	(R)	1/2"						
	Heat exchanger connector (female thread)	(R)	1"						
	Connector of exchanger sensor (female thread)	(R)	1/2"						
Number of turbulators	(pcs)	3	3	4	4	5	5	5	
Minimal distance from flammable objects	(mm)	1000							
Total current	(A)	2,9							

## Technical data - EKO-CK P + Cm Pelet-set 14-50

<b>Model identifier (TYPE):</b>		EKO-CK P 20 + Cm Pelet-set 14	EKO-CK P 25 + Cm Pelet-set 35	EKO-CK P 30 + Cm Pelet-set 35	EKO-CK P 35 + Cm Pelet-set 35	EKO-CK P 40 + Cm Pelet-set 35	EKO-CK P 50 + Cm Pelet-set 50	EKO-CK P 60 + Cm Pelet-set 50
Stoking mode		automatic						
The boiler should be operated with a hot water storage tank of a volume of at least (l)		280	400	500	600	700	800	1000
Condensing boiler		no						
Solid fuel cogeneration boiler		no						
Combination boiler		no						
Preferred fuel		Compressed wood in the form of pellets: <b>C1</b> (EN 303-5:2012); <b>A1</b> (EN ISO 17225-2)						
Seasonal space heating energy efficiency - $\eta_s$ (%)		78	79	80	80	80	81	81
Seasonal space heating emissions for preferred fuel ***	PM mg/m <sup>3</sup> (10% O <sub>2</sub> )	21	22	23	22	21	20	18
	OGC mg/m <sup>3</sup> (10% O <sub>2</sub> )	2	4	6	5	4	3	1
	CO mg/m <sup>3</sup> (10% O <sub>2</sub> )	76	131	177	165	153	140	116
	NO <sub>x</sub> mg/m <sup>3</sup> (10% O <sub>2</sub> )	168	136	109	105	102	98	91
Auxiliary electricity consumption	At rated heat output - $e_{l\ max}$ (kW)	0.065	0.071	0.075	0.076	0.076	0.078	0.080
	At 30 % of rated heat output - $e_{l\ min}$ (kW)	0.030	0.036	0.040	0.040	0.040	0.040	0.040
	Of incorporated secondary emission abatement equipment (kW)	Not applicable						
	In standby mod - $P_{SB}$ (kW)	0.004						

\* (dT 10°C-dT20°C)

\*\* set temp. range depends on the selected configuration

\*\*\* PM = particulate matter, OGC = organic gaseous compounds, CO = carbon monoxide, NO<sub>x</sub> = nitrogen oxides

**Contact details:**

Centrometal d.o.o. - Glavna 12, 40306 Macinec, Croatia



## Technical data - EKO-CK P + Cm Pelet-set 90

Model identifier (TYPE):		EKO-CK P 70 + Cm pelet-set 90	EKO-CK P 90 + Cm pelet-set 90	EKO-CK P 110 + Cm pelet-set 90	
Useful heat output at rated heat output - P <sub>n</sub>	(kW)	60	70	90	
Useful heat output at 30 % of rated heat output - P <sub>p</sub>	(kW)	18	21	27	
Useful efficiency at rated heat output (lower calorific value)	(%)	91.1	90.8	90.2	
Useful efficiency at 30 % of rated heat output (lower calorific value)	(%)	91.5	91.1	90.4	
Useful efficiency at rated heat output (gross calorific value „GCV“) -η <sub>n</sub>	(%)	83.8	83.4	82.5	
Useful efficiency at 30 of rated heat output (gross calorific value „GCV“) -η <sub>p</sub>	(%)	84.1	83.7	82.7	
Heat output range	(kW)	18-60	21-70	27-90	
Boiler		EKO-CK P 70	EKO-CK P 90	EKO-CK P 110	
Burner		CPPL-90	CPPL-90	CPPL-90	
Feeder screw		CPPT-90	CPPT-90	CPPT-90	
Pellet tank		CPSP-800	CPSP-800	CPSP-800	
Boiler class		5			
Required chimney underpressure	(mbar)	0.23	0.25	0.28	
Required chimney underpressure at min. power	(mbar)	0,05	0,1	0,1	
Water amount in boiler	(l)	135	140	160	
Exhaust gas temperature at nominal heat output	(°C)	160			
Exhaust gas temperature at min. heat output	(°C)	130			
Exhaust mass flow at nominal heat output	(kg/s)	0.05633	0.06573	0.08451	
Exhaust mass flow at minimum heat output	(kg/s)	0.03389	0.03946	0.04875	
Standby heat losses	(kW)	0,456	0,532	0,684	
Boiler resistance on water side at nominal output *	(mbar)	21,7-5,4	11,4-2,9	18,9-4,7	
Burning period at nominal power	(h)	6			
Temperature setting range by help of the regulation **	(°C)	70-90 / 75-90 / 80-90			
Lowest return temperature	(°C)	55			
Maximum heat input	(kW)	66,08	77,09	93,83	
Fuel size		fi 6 x max. 50			
Combustion chamber volume / pellet tank volume	(l)	218/800	242/800	277/800	
Combustion chamber dimension	(mm)	471x742x804	521x742x804	521x804x883	
Combustion chamber volume	(l)	280	310	370	
Combustion chamber type		overpressure			
Electrical power		250			
Voltage	(W)	230			
Frequency	(V~)	50			
Type of current	(Hz)	~			
Boiler dimensions with casing	Length (A)	(mm)	1250	1250	1350
	Width (B)	(mm)	640	690	690
	Height (C)	(mm)	1435	1435	1435
Boiler body mass	(kg)	389	415	452	
Total mass - (boiler with casing and accessories)	(kg)	429	455	500	
Max. operating overpressure	(bar)	2.5			
Test pressure	(bar)	5.5			
Max. operating temperature	(°C)	90			
Uptake tube - external diameter	(mm)	200			
Boiler connections	Flow and return pipe (male thread)	(R)	6/4"	6/4"	2"
	Charge/discharge (female thread)	(R)	1"		
	Heat exchanger connector (female thread)	(R)	1"		
	Connector of exchanger sensor (female thread)	(R)	1/2"		
Number of turbulators	(pcs)	4	5	5	
Minimal distance from flammable objects	(mm)	1000			
Total current	(A)	2.9			

## Technical data - EKO-CK P + Cm Pelet-set 90

Model identifier (TYPE):		EKO-CK P 70 + Cm pelet-set 90	EKO-CK P 90 + Cm pelet-set 90	EKO-CK P 110 + Cm pelet-set 90
Stoking mode		automatic		
The boiler should be operated with a hot water storage tank of a volume of at least (l)		1200	1400	1800
Condensing boiler		no		
Solid fuel cogeneration boiler		no		
Combination boiler		no		
Preferred fuel		Compressed wood in the form of pellets: <b>C1</b> (EN 303-5:2012); <b>A1</b> (EN ISO 17225-2)		
Seasonal space heating energy efficiency - $\eta_s$ (%)		81	80	79
Seasonal space heating emissions for preferred fuel ***	PM mg/m <sup>3</sup> (10% O <sub>2</sub> )	19	21	23
	OGC mg/m <sup>3</sup> (10% O <sub>2</sub> )	1	2	2
	CO mg/m <sup>3</sup> (10% O <sub>2</sub> )	107	97	78
	NO <sub>x</sub> mg/m <sup>3</sup> (10% O <sub>2</sub> )	110	130	168
Auxiliary electricity consumption	At rated heat output - el <sub>max</sub> (kW)	0.083	0.085	0.090
	At 30 % of rated heat output - el <sub>min</sub> (kW)	0.040	0.040	0.040
	Of incorporated secondary emission abatement equipment (kW)	Not applicable		
	In standby mod - P <sub>SB</sub> (kW)	0.004		

\* (dT 10°C-dT20°C)

\*\* set temp. range depends on the selected configuration

\*\*\* PM = particulate matter, OGC = organic gaseous compounds, CO = carbon monoxide, NO<sub>x</sub> = nitrogen oxides

**Contact details:**

Centrometal d.o.o. - Glavna 12, 40306 Macinec, Croatia

## Boiler dimensions - EKO-CK P + Cm Pelet-set 90

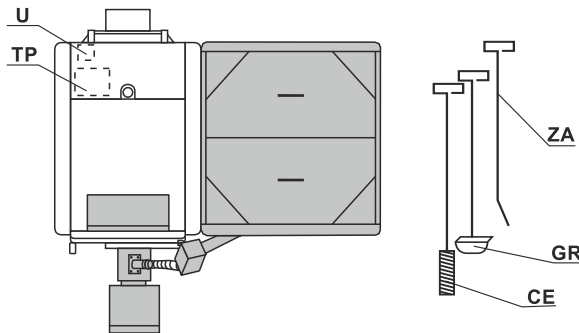
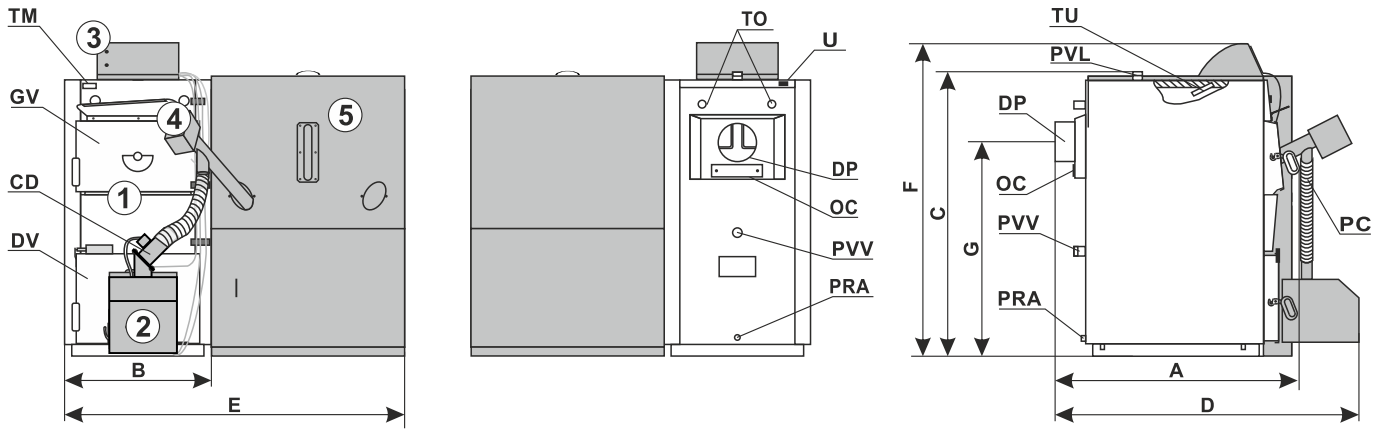

### NOTE:

Pellet tank CPSP can be positioned on the left side of the boiler (in this case it is necessary to turn supply tube for pellet loading on the burner CD for 180°).

- ① - Boiler EKO-CK P 70-110
- ② - Pellet burner CPPL-90
- ③ - Digital boiler controller CPREG / CPREG-Touch

- ④ - Pellet screw CPPT-90
- ⑤ - Pellet tank CPSP-800 or CPSP 70-110

### LEGEND:

- |   |   |
|---|---|
| <ul style="list-style-type: none"> <li>DV - Lower boiler door</li> <li>GV - Upper boiler door</li> <li>TM - Thermometer</li> <li>PRA - Filling / drainage</li> <li>PVV - Outlet line</li> <li>OC - Cleaning opening</li> <li>DP - Chimney connection</li> <li>PVL - Inlet line</li> <li>TU - Sensor sleeve</li> </ul> | <ul style="list-style-type: none"> <li>PC - Plastic flexible pipe</li> <li>U - Socket of the pump thermostat</li> <li>TO - Thermal protection connectors</li> <li>TP - Pump thermostat</li> <li>ZA - Poker</li> <li>GR - Scraper</li> <li>CE - Cleaning brush</li> <li>CD - Supply tube for pellet loading</li> </ul> |
|---|---|

Overall system dimensions	EKO-CK P + Cm pelet-set 60	EKO-CK P + Cm pelet-set 70	EKO-CK P + Cm pelet-set 90
Total length (D) (mm)	1610	1610	1710
Total width (E) (mm)	1650	1700	1700
Total height (F) (mm)	1600	1600	1600

## Technical data - EKO-CKB P + Cm Pelet-set 14-50

Model identifier (TYPE):		EKO-CKB P 20	EKO-CKB P 25	EKO-CKB P 30	EKO-CKB P 35	EKO-CKB P 40	EKO-CKB P 50	
		+ Cm Pelet-set 14	+ Cm Pelet-set 35	+ Cm Pelet-set 35	+ Cm Pelet-set 35	+ Cm Pelet-set 35	+ Cm Pelet-set 50	
Useful heat output at rated heat output - P <sub>n</sub>	(kW)	14	20	25	30	35	40	
Useful heat output at 30 % of rated heat output - P <sub>p</sub>	(kW)	4.2	6	7.5	9	10.5	12	
Useful efficiency at rated heat output (lower calorific value)	(%)	90.3	91.6	92.7	92.4	92.2	91.9	
Useful efficiency at 30 % of rated heat output (lower calorific value)	(%)	90.0	90.8	91.5	91.6	91.6	91.7	
Useful efficiency at rated heat output (gross calorific value „GCV“) -η <sub>n</sub>	(%)	82.6	84.1	85.4	85.2	84.9	84.7	
Useful efficiency at 30 of rated heat output (gross calorific value „GCV“) -η <sub>p</sub>	(%)	82.3	83.4	84.3	84.4	84.4	84.5	
Heat output range	(kW)	4.2-14	6-20	7.5-25	9-30	10,5-35	12-40	
Boiler		EKO-CK P 20	EKO-CK P 25	EKO-CK P 30	EKO-CK P 35	EKO-CK P 40	EKO-CK P 50	
Burner		CPPL-14	CPPL-35	CPPL-35	CPPL-35	CPPL-35	CPPL-50	
Feeder screw		CPPT	CPPT	CPPT	CPPT	CPPT	CPPT-50	
Pellet tank		CPSP	CPSP	CPSP	CPSP	CPSP	CPSP	
Boiler class		5						
Required chimney underpressure	(mbar)	0.11	0.12	0.13	0.14	0.15	0.20	
Required chimney underpressure at min. power	(mbar)	0.05						
Water amount in boiler	(l)	81	87	90	98	106	118	
Exhaust gas temperature at nominal heat output	(°C)	160						
Exhaust gas temperature at min. heat output	(°C)	100						
Exhaust mass flow at nominal heat output	(kg/s)	0.01309	0.01874	0.02345	0.02815	0.03284	0.03754	
Exhaust mass flow at minimum heat output	(kg/s)	0.0079	0.01111	0.01381	0.01702	0.01984	0.02267	
Standby heat losses	(kW)	0,15	0,217	0,266	0,288	0,309	0,34	
Boiler resistance on water side at nominal output *	(mbar)	2,2-0,5	4,4-1,1	6,9-1,7	10-2,5	13,6-3,4	17,7-4,4	
Burning period at nominal power	(h)	6						
Temperature setting range by help of the regulation **	(°C)	70-90 / 75-90 / 80-90						
Lowest return temperature	(°C)	55						
Maximum heat input	(kW)	15,6	22,2	27,8	33,33	38,88	44,44	
Fuel size		fi 6 x max 50						
Combustion chamber volume / pellet tank volume	(l)	75,4/370	80/370	92,5/370	105/370	116/370	161/370	
Combustion chamber dimension	(mm)	321x506x550	321x541x550	371x541x550	421x541x550	471x541x550	471x664x550	
Combustion chamber volume	(l)	89,3	95,5	110,3	125,2	140	172	
Combustion chamber type		overpressure						
Electrical power	(W)	250						
Voltage	(V~)	230						
Frequency	(Hz)	50						
Type of current		~						
Boiler dimensions with casing	Length (A)	(mm)	985	1020	1020	1020	1020	1142
	Width (B)	(mm)	470	470	520	570	620	620
	Height (C)	(mm)	1255	1255	1255	1255	1255	1255
Boiler body mass	(kg)	239	249	270	289	310	341	
Total mass - (boiler with casing and accessories)	(kg)	271	281	303	322	343	375	
Max. operating overpressure	(bar)	2,5						
Test pressure	(bar)	5,5						
Max. operating temperature	(°C)	90						
Uptake tube - external diameter	(mm)	150	150	160	160	180	180	
Boiler connections	Flow and return pipe (male thread)	(R)	5/4"					
	Charge/discharge (female thread)	(R)	1/2"					
	Heat exchanger connector (female thread)	(R)	1"					
	Connector of exchanger sensor (female thread)	(R)	1/2"					
Number of turbulators	(pcs)	3	3	4	4	5	5	
Minimal distance from flammable objects	(mm)	1000						
Total current	(A)	2,9						

## Technical data - EKO-CKB P + Cm Pelet-set 14-50

<b>Model identifier (TYPE):</b>		EKO-CKB P 20 + Cm Pelet-set 14	EKO-CKB P 25 + Cm Pelet-set 35	EKO-CKB P 30 + Cm Pelet-set 35	EKO-CKB P 35 + Cm Pelet-set 35	EKO-CKB P 40 + Cm Pelet-set 35	EKO-CKB P 50 + Cm Pelet-set 50
Stoking mode		automatic					
The boiler should be operated with a hot water storage tank of a volume of at least (l)		280	400	500	600	700	800
Condensing boiler		no					
Solid fuel cogeneration boiler		no					
Combination boiler		no					
Preferred fuel		Compressed wood in the form of pellets: C1 (EN 303-5:2012); A1 (EN ISO 17225-2)					
Seasonal space heating energy efficiency - $\eta_s$ (%)		78	79	80	80	80	81
Seasonal space heating emissions for preferred fuel ***	PM mg/m <sup>3</sup> (10% O <sub>2</sub> )	21	22	23	22	21	20
	OGC mg/m <sup>3</sup> (10% O <sub>2</sub> )	2	4	6	5	4	3
	CO mg/m <sup>3</sup> (10% O <sub>2</sub> )	76	131	177	165	153	140
	NO <sub>x</sub> mg/m <sup>3</sup> (10% O <sub>2</sub> )	168	136	109	105	102	98
Auxiliary electricity consumption	At rated heat output - $e_{l_{max}}$ (kW)	0.065	0.071	0.075	0.076	0.076	0.078
	At 30 % of rated heat output - $e_{l_{min}}$ (kW)	0.030	0.036	0.040	0.040	0.040	0.040
	Of incorporated secondary emission abatement equipment (kW)	Not applicable					
	In standby mod - $P_{SB}$ (kW)	0.004					

\* (dT 10°C-dT20°C)

\*\* set temp. range depends on the selected configuration

\*\*\* PM = particulate matter, OGC = organic gaseous compounds, CO = carbon monoxide, NO<sub>x</sub> = nitrogen oxides

**Contact details:**

Centrometal d.o.o. - Glavna 12, 40306 Macinec, Croatia

